



# 4N80

Power MOSFET

## 4.0A, 800V N-CHANNEL POWER MOSFET

### DESCRIPTION

The UTC **4N80** is a N-channel mode power MOSFET using UTC's advanced technology to provide customers planar stripe and DMOS technology. This technology is specialized in allowing a minimum on-state resistance, and superior switching performance. It also can withstand high energy pulse in the avalanche and commutation mode.

The UTC **4N80** is universally applied in high efficiency switch mode power supply.

### FEATURES

- \*  $R_{DS(on)} < 3.0\Omega$  @  $V_{GS}=10V, I_D=2.0A$
- \* High switching speed
- \* Improved dv/dt capability
- \* 100% avalanche tested

### SYMBOL

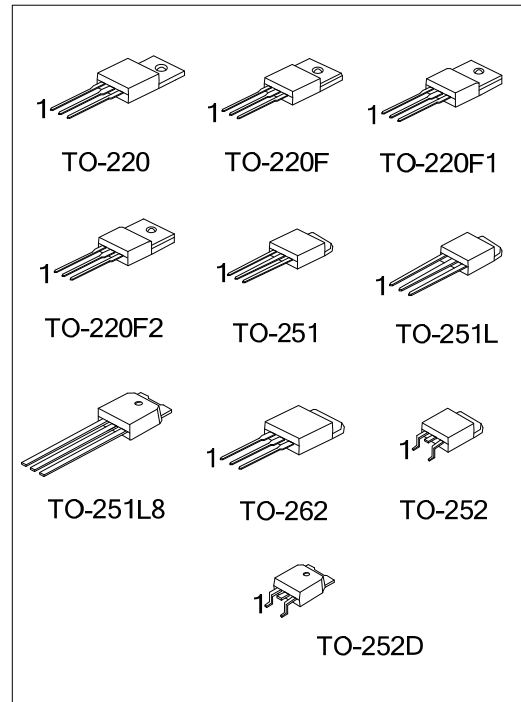
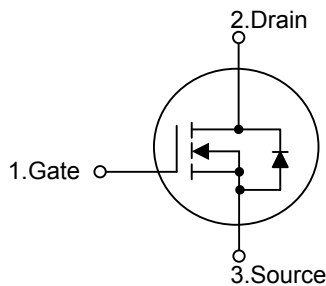

## ORDERING INFORMATION

| Ordering Number |              | Package  | Pin Assignment |   |   | Packing   |
|-----------------|--------------|----------|----------------|---|---|-----------|
| Lead Free       | Halogen Free |          | 1              | 2 | 3 |           |
| 4N80L-TA3-T     | 4N80G-TA3-T  | TO-220   | G              | D | S | Tube      |
| 4N80L-TF1-T     | 4N80G-TF1-T  | TO-220F1 | G              | D | S | Tube      |
| 4N80L-TF2-T     | 4N80G-TF2-T  | TO-220F2 | G              | D | S | Tube      |
| 4N80L-TF3-T     | 4N80G-TF3-T  | TO-220F  | G              | D | S | Tube      |
| 4N80L-TM3-T     | 4N80G-TM3-T  | TO-251   | G              | D | S | Tube      |
| 4N80L-TMA-T     | 4N80G-TMA-T  | TO-251L  | G              | D | S | Tube      |
| 4N80L-TMA8-T    | 4N80G-TMA8-T | TO-251L8 | G              | D | S | Tube      |
| 4N80L-TN3-R     | 4N80G-TN3-R  | TO-252   | G              | D | S | Tape Reel |
| 4N80L-TND-R     | 4N80G-TND-R  | TO-252D  | G              | D | S | Tape Reel |
| 4N80L-T2Q-T     | 4N80G-T2Q-T  | TO-262   | G              | D | S | Tube      |

Note: Pin Assignment: G: Gate D: Drain S: Source

|   |   |
|---|---|
| <p>4N80L-TA3-T</p> <p>(1) Packing Type<br/>(2) Package Type<br/>(3) Green Package</p> | <p>(1) T: Tube, R: Tape Reel<br/>(2) TA3: TO-220, TF3: TO-220F, TF1: TO-220F1<br/>TF2: TO-220F2, TM3: TO-251, TMA: TO-251L<br/>TMA8: TO-251L8, TN3: TO-252,<br/>TND: TO-252D, T2Q: TO-262<br/>(3) L: Lead Free, G: Halogen Free and Lead Free</p> |
|---|---|

## MARKING

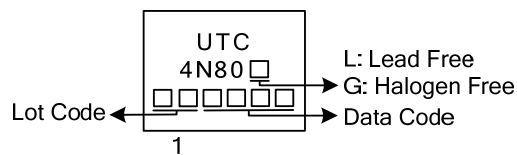

■ ABSOLUTE MAXIMUM RATINGS ( $T_c=25^\circ\text{C}$ , unless otherwise specified)

| PARAMETER                          |  | SYMBOL    | RATINGS    | UNIT             |
|------------------------------------|--|-----------|------------|------------------|
| Drain-Source Voltage               |  | $V_{DSS}$ | 800        | V                |
| Gate-Source Voltage                |  | $V_{GSS}$ | $\pm 30$   | V                |
| Drain Current                      | Continuous                                   | $I_D$     | 4.0        | A                |
|                                    | Pulsed (Note 2)                              | $I_{DM}$  | 16         | A                |
| Avalanche Energy                   | Single Pulsed (Note 3)                       | $E_{AS}$  | 460        | mJ               |
|                                    | Repetitive (Note 2)                          | $E_{AR}$  | 13         | mJ               |
| Peak Diode Recovery dv/dt (Note 4) |  | dv/dt     | 4.0        | V/ns             |
| Power Dissipation                  | TO-220/TO-262                                | $P_D$     | 106        | W                |
|                                    | TO-220F/TO-220F1                             |           | 36         | W                |
|                                    | TO-220F2                                     |           | 38         | W                |
|                                    | TO-251/TO-251L<br>TO-251L8/TO-252<br>TO-252D |           | 50         | W                |
|                                    | Junction Temperature                         |           | $T_J$      | +150             |
| Storage Temperature                |  | $T_{STG}$ | -55 ~ +150 | $^\circ\text{C}$ |

Notes: 1. Absolute maximum ratings are those values beyond which the device could be permanently damaged.

Absolute maximum ratings are stress ratings only and functional device operation is not implied.

2. Repetitive Rating: Pulse width limited by maximum junction temperature

3.  $L=57\text{mH}$ ,  $I_{AS}=4\text{A}$ ,  $V_{DD}=50\text{V}$ ,  $R_G=25\Omega$ , Starting  $T_J=25^\circ\text{C}$

4.  $I_{SD}\leq 4\text{A}$ ,  $di/dt\leq 200\text{A}/\mu\text{s}$ ,  $V_{DD}\leq BV_{DSS}$ , Starting  $T_J=25^\circ\text{C}$

■ THERMAL DATA

| PARAMETER           |   | SYMBOL        | RATINGS | UNIT                      |
|---------------------|---|---------------|---------|---------------------------|
| Junction to Ambient | TO-220/TO-220F<br>TO-220F1/TO-220F2<br>TO-262 | $\theta_{JA}$ | 62.5    | $^\circ\text{C}/\text{W}$ |
|                     | TO-251/TO-251L<br>TO-251L8/TO-252<br>TO-252D  |               | 110     | $^\circ\text{C}/\text{W}$ |
| Junction to Case    | TO-220/TO-262                                 | $\theta_{JC}$ | 1.18    | $^\circ\text{C}/\text{W}$ |
|                     | TO-220F/TO-220F1                              |               | 3.47    | $^\circ\text{C}/\text{W}$ |
|                     | TO-220F2                                      |               | 3.28    | $^\circ\text{C}/\text{W}$ |
|                     | TO-251/TO-251L<br>TO-251L8/TO-252<br>TO-252D  |               | 2.5     | $^\circ\text{C}/\text{W}$ |

■ ELECTRICAL CHARACTERISTICS (T<sub>c</sub>=25°C, unless otherwise specified)

| PARAMETER  | SYMBOL                              | TEST CONDITIONS  | MIN | TYP | MAX  | UNIT  |
|--|-------------------------------------|--|-----|-----|------|-------|
| <b>OFF CHARACTERISTICS</b>                             |                                     |  |     |     |      |       |
| Drain-Source Breakdown Voltage                         | BV <sub>DSS</sub>                   | V <sub>GS</sub> =0V, I <sub>D</sub> =250μA                                       | 800 |     |      | V     |
| Breakdown Voltage Temperature Coefficient              | ΔBV <sub>DSS</sub> /ΔT <sub>J</sub> | I <sub>D</sub> =250μA, Referenced to 25°C  |     | 950 |      | mV/°C |
| Drain-Source Leakage Current                           | I <sub>DSS</sub>                    | V <sub>DS</sub> =800V, V <sub>GS</sub> =0V                                       |     |     | 10   | μA    |
|  |                                     | V <sub>DS</sub> =640V, T <sub>C</sub> =125°C                                     |     |     | 100  | μA    |
| Gate-Source Leakage Current                            | Forward                             | I <sub>GSS</sub>   |     |     |      | nA    |
|  | Reverse                             |  |     |     |      |       |
|  |                                     | V <sub>DS</sub> =0V, V <sub>GS</sub> =-30V                                       |     |     | -100 | nA    |
| <b>ON CHARACTERISTICS</b>                              |                                     |  |     |     |      |       |
| Gate Threshold Voltage                                 | V <sub>GS(TH)</sub>                 | V <sub>DS</sub> =V <sub>GS</sub> , I <sub>D</sub> =250μA                         | 3.0 |     | 5.0  | V     |
| Drain-Source On-State Resistance                       | R <sub>DS(ON)</sub>                 | V <sub>GS</sub> =10V, I <sub>D</sub> =2.0A                                       |     | 2.3 | 3.0  | Ω     |
| <b>DYNAMIC PARAMETERS</b>                              |                                     |  |     |     |      |       |
| Input Capacitance                                      | C <sub>ISS</sub>                    | V <sub>GS</sub> =0V, V <sub>DS</sub> =25V,<br>f=1.0MHz                           |     | 680 | 880  | pF    |
| Output Capacitance                                     | C <sub>OSS</sub>                    |  |     | 75  | 100  | pF    |
| Reverse Transfer Capacitance                           | C <sub>RSS</sub>                    |  |     | 8.6 | 12   | pF    |
| <b>SWITCHING PARAMETERS</b>                            |                                     |  |     |     |      |       |
| Total Gate Charge (Note 1)                             | Q <sub>G</sub>                      | V <sub>DS</sub> =640V, V <sub>GS</sub> =10V,<br>I <sub>D</sub> =4A (Note 1,2)    |     | 19  | 25   | nC    |
| Gate-Source Charge                                     | Q <sub>GS</sub>                     |  |     | 4.2 |      | nC    |
| Gate-Drain Charge                                      | Q <sub>GD</sub>                     |  |     | 9.1 |      | nC    |
| Turn-ON Delay Time (Note 1)                            | t <sub>D(ON)</sub>                  | V <sub>DD</sub> =400V, I <sub>D</sub> =4A,<br>R <sub>G</sub> =25Ω (Note 1,2)     |     | 16  | 40   | ns    |
| Turn-ON Rise Time                                      | t <sub>R</sub>                      |  |     | 45  | 100  | ns    |
| Turn-OFF Delay Time                                    | t <sub>D(OFF)</sub>                 |  |     | 35  | 80   | ns    |
| Turn-OFF Fall Time                                     | t <sub>F</sub>                      |  |     | 35  | 80   | ns    |
| <b>SOURCE- DRAIN DIODE RATINGS AND CHARACTERISTICS</b> |                                     |  |     |     |      |       |
| Maximum Body-Diode Continuous Current                  | I <sub>S</sub>                      |  |     |     | 4    | A     |
| Maximum Body-Diode Pulsed Current                      | I <sub>SM</sub>                     |  |     |     | 16   | A     |
| Drain-Source Diode Forward Voltage (Note 1)            | V <sub>SD</sub>                     | I <sub>S</sub> =4A, V <sub>GS</sub> =0V  |     |     | 1.4  | V     |
| Body Diode Reverse Recovery Time (Note 1)              | t <sub>rr</sub>                     | V <sub>GS</sub> =0V, I <sub>S</sub> =4A,<br>dI <sub>F</sub> /dt=100A/μs (Note 1) |     | 575 |      | ns    |
| Body Diode Reverse Recovery Charge                     | Q <sub>rr</sub>                     |  |     |     | 3.65 |       |

Notes: 1. Pulse Test: Pulse width ≤ 300μs, Duty cycle ≤ 2%.

2. Essentially independent of operating temperature.



■ TEST CIRCUITS AND WAVEFORMS(Cont.)

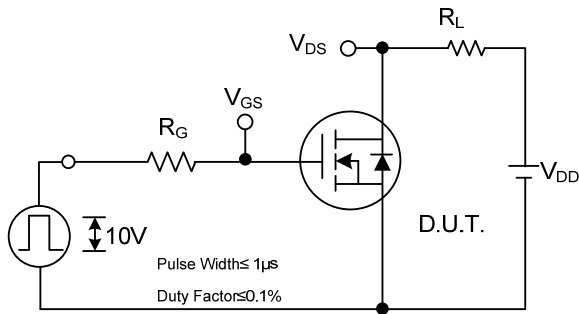

Switching Test Circuit

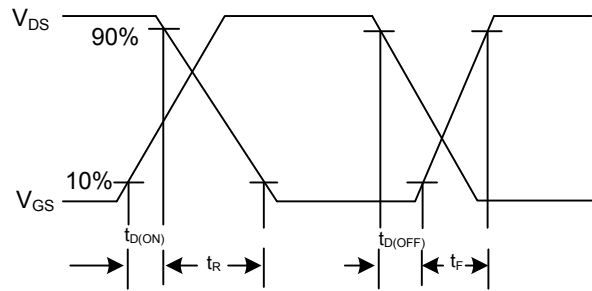

Switching Waveforms

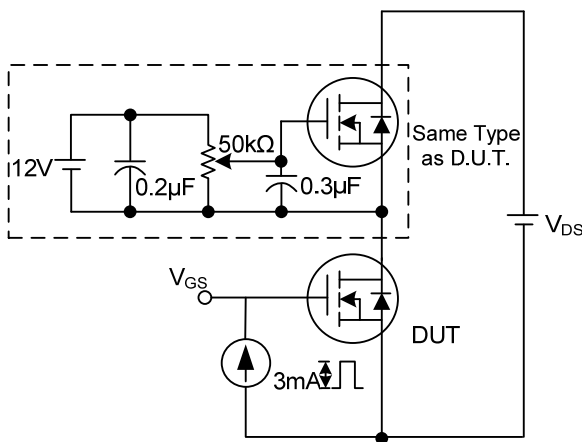

Gate Charge Test Circuit

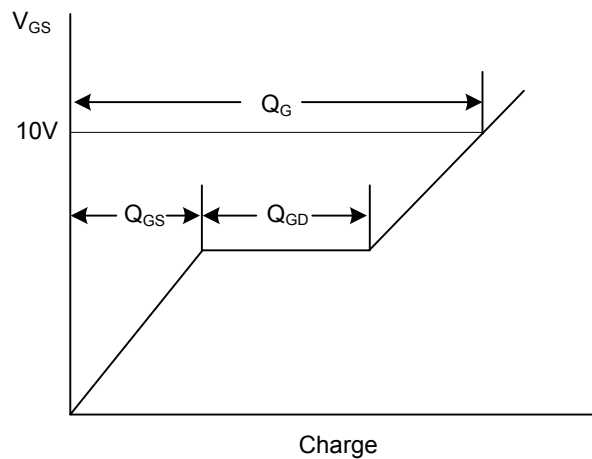

Gate Charge Waveform

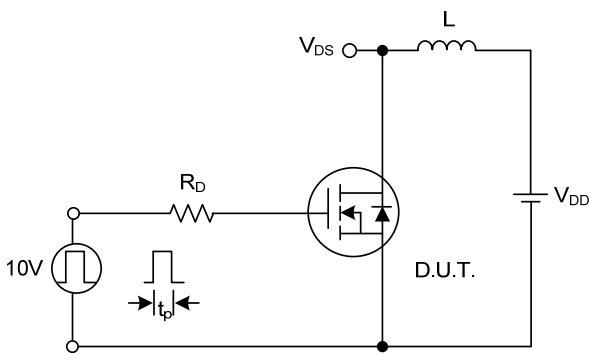

Unclamped Inductive Switching Test Circuit

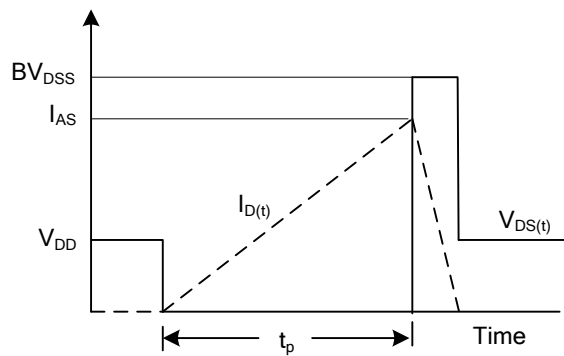

Unclamped Inductive Switching Waveforms

■ TYPICAL CHARACTERISTICS

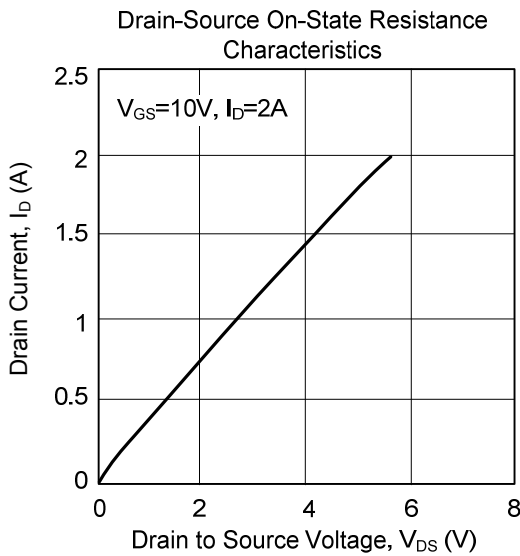
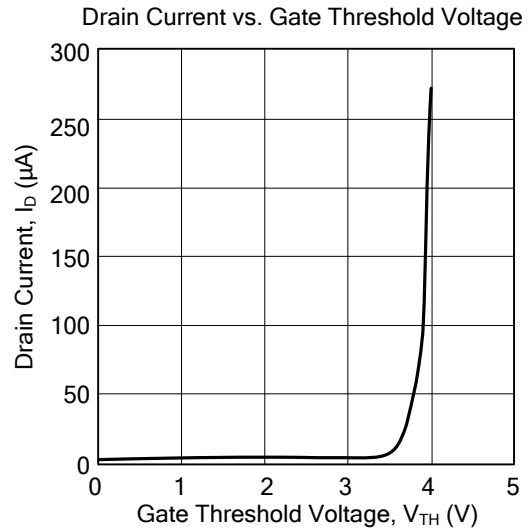
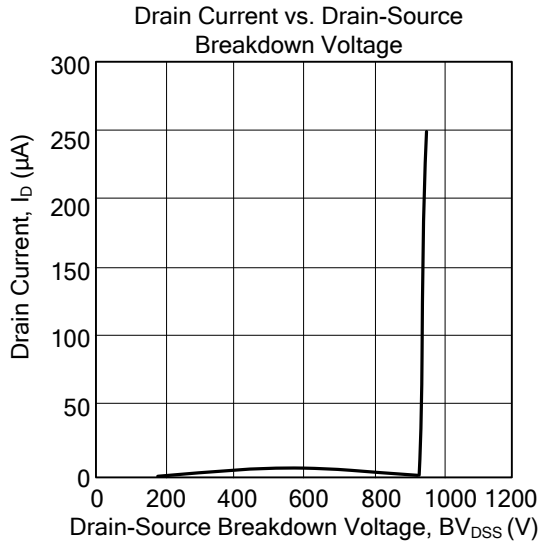

UTC assumes no responsibility for equipment failures that result from using products at values that exceed, even momentarily, rated values (such as maximum ratings, operating condition ranges, or other parameters) listed in products specifications of any and all UTC products described or contained herein. UTC products are not designed for use in life support appliances, devices or systems where malfunction of these products can be reasonably expected to result in personal injury. Reproduction in whole or in part is prohibited without the prior written consent of the copyright owner. The information presented in this document does not form part of any quotation or contract, is believed to be accurate and reliable and may be changed without notice.

## X-ON Electronics

Largest Supplier of Electrical and Electronic Components

*Click to view similar products for [MOSFET](#) category:*

*Click to view products by [Unisonic](#) manufacturer:*

Other Similar products are found below :

[614233C](#) [648584F](#) [MCH3443-TL-E](#) [MCH6422-TL-E](#) [FDPF9N50NZ](#) [FW216A-TL-2W](#) [FW231A-TL-E](#) [APT5010JVR](#) [NTNS3A92PZT5G](#)  
[IRF100S201](#) [JANTX2N5237](#) [2SK2464-TL-E](#) [2SK3818-DL-E](#) [FCA20N60\\_F109](#) [FDZ595PZ](#) [STD6600NT4G](#) [FSS804-TL-E](#) [2SJ277-DL-E](#)  
[2SK1691-DL-E](#) [2SK2545\(Q,T\)](#) [D2294UK](#) [405094E](#) [423220D](#) [MCH6646-TL-E](#) [TPCC8103,L1Q\(CM](#) [367-8430-0972-503](#) [VN1206L](#)  
[424134F](#) [026935X](#) [051075F](#) [SBVS138LT1G](#) [614234A](#) [715780A](#) [NTNS3166NZT5G](#) [751625C](#) [873612G](#) [IRF7380TRHR](#)  
[IPS70R2K0CEAKMA1](#) [RJK60S3DPP-E0#T2](#) [RJK60S5DPK-M0#T0](#) [APT5010JVFR](#) [APT12031JFLL](#) [APT12040JVR](#) [DMN3404LQ-7](#)  
[NTE6400](#) [JANTX2N6796U](#) [JANTX2N6784U](#) [JANTXV2N5416U4](#) [SQM110N05-06L-GE3](#) [SIHF35N60E-GE3](#)