



78DXX

LINEAR INTEGRATED CIRCUIT

3-TERMINALS 0.5A POSITIVE VOLTAGE REGULATOR

DESCRIPTION

The UTC 78DXX family is monolithic fixed voltage regulator integrated circuit. They are suitable for applications that required supply current up to 0.5 A.

FEATURE

- * Output Current Up To 0.5 A
- * Fixed Output Voltage Of 5V, 6V, 7V, 8V, 9V, 10, 12V, 15V, 18V, 20V and 24V Available
- * Thermal Overload Shutdown Protection
- * Short Circuit Current Limiting
- * Output Transistor SOA Protection

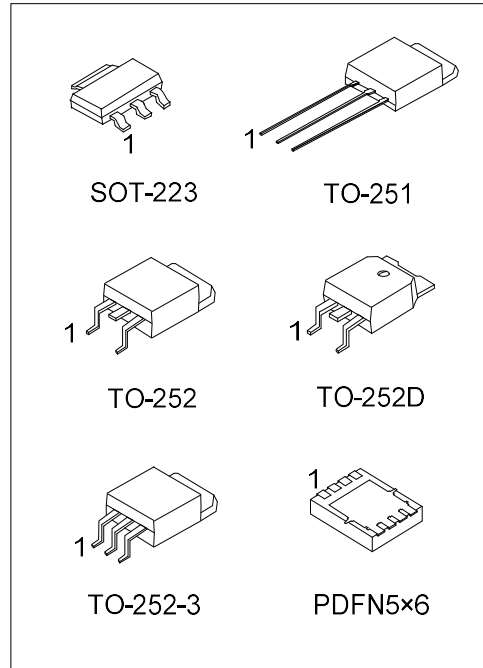

ORDERING INFORMATION

Ordering Number		Package	Pin Assignment								Packing
Lead Free	Halogen Free		1	2	3	4	5	6	7	8	
78DXXL-AA3-R	78DXXG-AA3-R	SOT-223	I	G	O	-	-	-	-	-	Tape Reel
78DXXL-TM3-T	78DXXG-TM3-T	TO-251	I	G	O	-	-	-	-	-	Tube
78DXXL-TN3-R	78DXXG-TN3-R	TO-252	I	G	O	-	-	-	-	-	Tape Reel
78DXXL-TNA-R	78DXXG-TNA-R	TO-252-3	I	G	O	-	-	-	-	-	Tape Reel
78DXXL-TND-R	78DXXG-TND-R	TO-252D	I	G	O	-	-	-	-	-	Tape Reel
78DXXL-P5060-R	78DXXG-P5060-R	PDFN5x6	I	I	I	O	G	G	G	G	Tape Reel

Note: 1. XX: Output Voltage, refer to Marking Information
 2. Pin Code: I: Input G: GND O: Output

<p>78DXXG-AA3-R</p>	<p>(1) R: Tape Reel, T: Tube (2) AA3: SOT-223, TM3: TO-251, TN3: TO-252, TNA: TO-252-3, TND: TO-252D, P5060: PDFN5x6 (3) G: Halogen Free and Lead Free, L: Lead Free (4) XX: refer to Marking Information</p>
---------------------	--

MARKING INFORMATION

PACKAGE	VOLTAGE CODE	MARKING
SOT-223		<p>L: Lead Free G: Halogen Free Voltage Code Date Code</p>
TO-251 TO-252 TO-252-3 TO-252D	05: 5V 06: 6V 07: 7V 08: 8V 09: 9V 10: 10V 12: 12V 15: 15V 18: 18V	<p>UTC 78DXX Voltage Code Lot Code L: Lead Free G: Halogen Free Date Code</p>
PDFN5x6	20: 20V 24: 24V	<p>UTC 78 DXX Lot Code L: Lead Free G: Halogen Free Date Code</p>

PIN CONFIGURATION

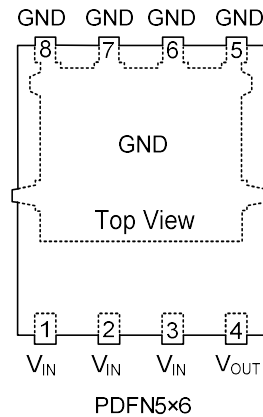

■ BLOCK DIAGRAM

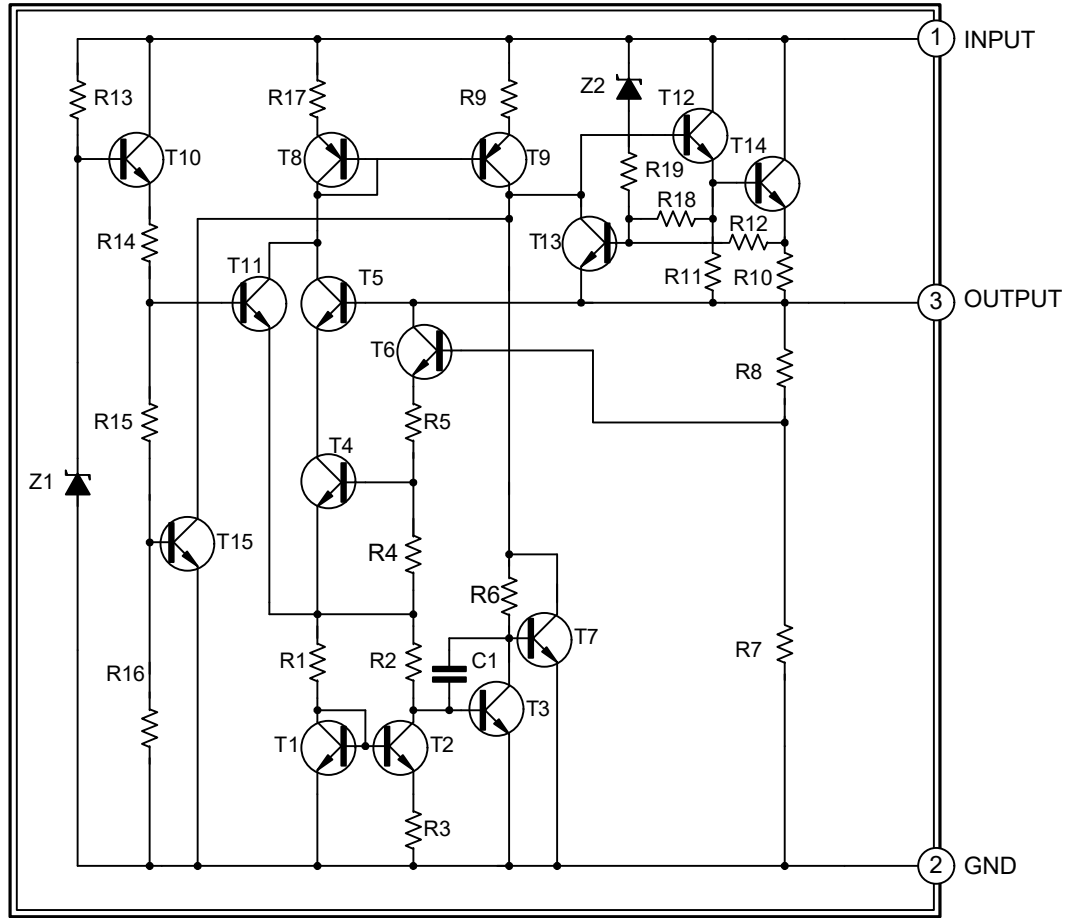

■ TYPICAL APPLICATION CIRCUIT

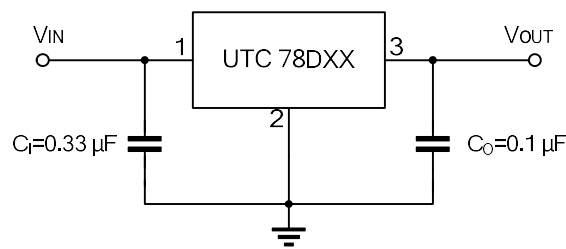

Note: Bypass capacitors are recommended for optimum stability and transient response and should be located as close as possible to the regulators.

■ **ABSOLUTE MAXIMUM RATINGS** ($T_J=25^\circ\text{C}$, unless otherwise specified)

PARAMETER		SYMBOL	RATINGS	UNIT
Input Voltage		V_{IN}	35	V
Output Current		I_{OUT}	0.5	A
Power Dissipation ($T_C=25^\circ\text{C}$)	SOT-223	P_D	8.3	W
	TO-251/TO-252 TO-252-3/TO-252D		10	W
	PDFN5×6		8.0	W
Operating Junction Temperature		T_J	+150	$^\circ\text{C}$
Operating Temperature		T_{OPR}	-40 ~ +125	$^\circ\text{C}$
Storage Temperature		T_{STG}	-65 ~ +150	$^\circ\text{C}$

Note: Absolute maximum ratings are those values beyond which the device could be permanently damaged. Absolute maximum ratings are stress ratings only and functional device operation is not implied.

■ **THERMAL DATA**

PARAMETER		SYMBOL	RATINGS	UNIT
Junction to Case	SOT-223	θ_{JC}	15	$^\circ\text{C/W}$
	TO-251/TO-252 TO-252-3/TO-252D		12.5	$^\circ\text{C/W}$
	PDFN5×6		15.6	$^\circ\text{C/W}$

■ **ELECTRICAL CHARACTERISTICS**

($T_J=25^\circ\text{C}$, $C_I=0.33\mu\text{F}$, $C_O=0.1\mu\text{F}$, $P_D\leq 7\text{W}$, unless otherwise specified)

For 78D05 ($V_{IN}=10\text{V}$, $I_{OUT}=0.5\text{A}$)

PARAMETER	SYMBOL	TEST CONDITIONS	MIN	TYP	MAX	UNIT
Output Voltage	V_{OUT}	$I_{OUT}=5\text{mA}\sim 0.5\text{A}$	4.8	5	5.2	V
		$V_{IN}=7.5\sim 20\text{V}$, $I_{OUT}=5\text{mA}\sim 0.5\text{A}$	4.75		5.25	V
Load Regulation	ΔV_{OUT}	$I_{OUT}=5\text{mA}\sim 0.5\text{A}$			50	mV
		$I_{OUT}=5\text{mA}\sim 200\text{mA}$			25	mV
Line Regulation	ΔV_{OUT}	$V_{IN}=7\text{V}\sim 25\text{V}$			50	mV
		$V_{IN}=7.5\sim 20\text{V}$, $I_{OUT}=0.5\text{A}$			50	mV
Quiescent Current	I_Q	$I_{OUT}=0.5\text{A}$			8	mA
Quiescent Current Change	ΔI_Q	$V_{UT}=7.5\sim 20\text{V}$			1	mA
		$I_{OUT}=5\text{mA}\sim 0.5\text{A}$			0.5	mA
Output Noise Voltage	eN	10Hz $\leq f \leq$ 100kHz		40		μV
Ripple Rejection	RR	$V_{IN}=8\sim 18\text{V}$, $f=120\text{Hz}$	59	80		dB
Peak Output Current	I_{PEAK}			1.2		A
Short-Circuit Current	I_{SC}	$V_{IN}=V_{OUT}+19\text{V}$		250		mA
Dropout Voltage	V_D			2		V

■ ELECTRICAL CHARACTERISTICS (Cont.)

For 78D06 ($V_{IN}=11V$, $I_{OUT}=0.5A$)

PARAMETER	SYMBOL	TEST CONDITIONS	MIN	TYP	MAX	UNIT
Output Voltage	V_{OUT}	$I_{OUT}=5mA\sim 0.5A$	5.76	6	6.24	V
		$V_{IN}=8.5\sim 21V, I_{OUT}=5mA\sim 0.5A$	5.7		6.3	V
Load Regulation	ΔV_{OUT}	$I_{OUT}=5mA\sim 0.5A$			60	mV
		$I_{OUT}=5mA\sim 200mA$			30	mV
Line Regulation	ΔV_{OUT}	$V_{IN}=8\sim 25V$			60	mV
		$V_{IN}=8.5\sim 21V, I_{OUT}=0.5A$			60	mV
Quiescent Current	I_Q	$I_{OUT}=0.5A$			8	mA
Quiescent Current Change	ΔI_Q	$V_{IN}=8.5\sim 21V$			1	mA
		$I_{OUT}=5mA\sim 0.5A$			0.5	mA
Output Noise Voltage	eN	$10Hz\leq f\leq 100kHz$		45		μV
Ripple Rejection	RR	$V_{IN}=9\sim 19V, f=120Hz$	56	75		dB
Peak Output Current	I_{PEAK}			1.2		A
Short-Circuit Current	I_{SC}	$V_{IN}=V_{OUT}+19V$		250		mA
Dropout Voltage	V_D			2		V

For 78D07 ($V_{IN}=13V$, $I_{OUT}=0.5A$)

PARAMETER	SYMBOL	TEST CONDITIONS	MIN	TYP	MAX	UNIT
Output Voltage	V_{OUT}	$I_{OUT}=5mA\sim 0.5A$	6.72	7	7.28	V
		$V_{IN}=9.5\sim 22V, I_{OUT}=5mA\sim 0.5A$	6.65		7.35	V
Load Regulation	ΔV_{OUT}	$I_{OUT}=5mA\sim 0.5A$			70	mV
		$I_{OUT}=5mA\sim 200mA$			35	mV
Line Regulation	ΔV_{OUT}	$V_{IN}=10.5\sim 25V$			70	mV
		$V_{IN}=10.5\sim 23V, I_{OUT}=0.5A$			70	mV
Quiescent Current	I_Q	$I_{OUT}=0.5A$			8	mA
Quiescent Current Change	ΔI_Q	$V_{IN}=10.5\sim 23V$			1	mA
		$I_{OUT}=5mA\sim 0.5A$			0.5	mA
Output Noise Voltage	eN	$10Hz\leq f\leq 100kHz$		50		μV
Ripple Rejection	RR	$V_{IN}=11.5\sim 21.5V, f=120Hz$	56	75		dB
Peak Output Current	I_{PEAK}			1.2		A
Short-Circuit Current	I_{SC}	$V_{IN}=V_{OUT}+19V$		250		mA
Dropout Voltage	V_D			2		V

For 78D08 ($V_{IN}=14V$, $I_{OUT}=0.5A$)

PARAMETER	SYMBOL	TEST CONDITIONS	MIN	TYP	MAX	UNIT
Output Voltage	V_{OUT}	$I_{OUT}=5mA\sim 0.5A$	7.68	8	8.32	V
		$V_{IN}=10.5\sim 23V, I_{OUT}=5mA\sim 0.5A$	7.6		8.4	V
Load Regulation	ΔV_{OUT}	$I_{OUT}=5mA\sim 0.5A$			80	mV
		$I_{OUT}=5mA\sim 200mA$			40	mV
Line Regulation	ΔV_{OUT}	$V_{IN}=10.5\sim 25V$			80	mV
		$V_{IN}=10.5\sim 23V, I_{OUT}=0.5A$			80	mV
Quiescent Current	I_Q	$I_{OUT}=0.5A$			8	mA
Quiescent Current Change	ΔI_Q	$V_{IN}=10.5\sim 23V$			1	mA
		$I_{OUT}=5mA\sim 0.5A$			0.5	mA
Output Noise Voltage	eN	$10Hz\leq f\leq 100kHz$		58		μV
Ripple Rejection	RR	$V_{IN}=11.5\sim 21.5V, f=120Hz$	53	72		dB
Peak Output Current	I_{PEAK}			1.2		A
Short-Circuit Current	I_{SC}	$V_{IN}=V_{OUT}+19V$		250		mA
Dropout Voltage	V_D			2		V

■ ELECTRICAL CHARACTERISTICS (Cont.)

For 78D09 ($V_{IN}=15V$, $I_{OUT}=0.5A$)

PARAMETER	SYMBOL	TEST CONDITIONS	MIN	TYP	MAX	UNIT
Output Voltage	V_{OUT}	$I_{OUT}=5mA\sim 0.5A$	8.64	9	9.36	V
		$V_{IN}=11.5\sim 24V, I_{OUT}=5mA\sim 0.5A$	8.55		9.45	V
Load Regulation	ΔV_{OUT}	$I_{OUT}=5mA\sim 0.5A$			90	mV
		$I_{OUT}=5mA\sim 200mA$			45	mV
Line Regulation	ΔV_{OUT}	$V_{IN}=11.5\sim 25V$			90	mV
		$V_{IN}=11.5\sim 24V, I_{OUT}=0.5A$			90	mV
Quiescent Current	I_Q	$I_{OUT}=1.0A$			8	mA
Quiescent Current Change	ΔI_Q	$V_{IN}=11.5\sim 24V$			1	mA
		$I_{OUT}=5mA\sim 0.5A$			0.5	mA
Output Noise Voltage	eN	$10Hz\leq f\leq 100kHz$		58		μV
Ripple Rejection	RR	$V_{IN}=12.5\sim 22.5V, f=120Hz$	53	72		dB
Peak Output Current	I_{PEAK}			1.2		A
Short-Circuit Current	I_{SC}	$V_{IN}=V_{OUT}+19V$		250		mA
Dropout Voltage	V_D			2		V

For 78D10 ($V_{IN}=16V$, $I_{OUT}=0.5A$)

PARAMETER	SYMBOL	TEST CONDITIONS	MIN	TYP	MAX	UNIT
Output Voltage	V_{OUT}	$I_{OUT}=5mA\sim 0.5A$	9.60	10	10.40	V
		$V_{IN}=12.5\sim 25V, I_{OUT}=5mA\sim 0.5A$	9.5		10.5	V
Load Regulation	ΔV_{OUT}	$I_{OUT}=5mA\sim 0.5A$			100	mV
		$I_{OUT}=5mA\sim 200mA$			50	mV
Line Regulation	ΔV_{OUT}	$V_{IN}=12.5\sim 25V$			100	mV
		$V_{IN}=12.5\sim 25V, I_{OUT}=0.5A$			100	mV
Quiescent Current	I_Q	$I_{OUT}=0.5A$			8.0	mA
Quiescent Current Change	ΔI_Q	$V_{IN}=12.6V\sim 25V$			1.0	mA
		$I_{OUT}=5mA\sim 0.5A$			0.5	mA
Output Noise Voltage	eN	$10Hz\leq f\leq 100kHz$		58		μV
Ripple Rejection	RR	$V_{IN}=13\sim 23V, f=120Hz$	53	72		dB
Peak Output Current	I_{PEAK}			1.2		A
Short-Circuit Current	I_{SC}	$V_{IN}=V_{OUT}+19V$		250		mA
Dropout Voltage	V_D			2		V

For 78D12 ($V_{IN}=19V$, $I_{OUT}=0.5A$)

PARAMETER	SYMBOL	TEST CONDITIONS	MIN	TYP	MAX	UNIT
Output Voltage	V_{OUT}	$I_{OUT}=5mA\sim 0.5A$	11.52	12	12.48	V
		$V_{IN}=14.5\sim 27V, I_{OUT}=5mA\sim 0.5A$	11.4		12.6	V
Load Regulation	ΔV_{OUT}	$I_{OUT}=5mA\sim 0.5A$			120	mV
		$I_{OUT}=5mA\sim 200mA$			60	mV
Line Regulation	ΔV_{OUT}	$V_{IN}=14.5\sim 30V$			120	mV
		$V_{IN}=14.6\sim 27V, I_{OUT}=0.5A$			120	mV
Quiescent Current	I_Q	$I_{OUT}=0.5A$			8	mA
Quiescent Current Change	ΔI_Q	$V_{IN}=14.5\sim 30V$			1	mA
		$I_{OUT}=5mA\sim 0.5A$			0.5	mA
Output Noise Voltage	eN	$10Hz\leq f\leq 100kHz$		75		μV
Ripple Rejection	RR	$V_{IN}=15\sim 25V, f=120Hz$	52	72		dB
Peak Output Current	I_{PEAK}			1.2		A
Short-Circuit Current	I_{SC}	$V_{IN}=V_{OUT}+19V$		250		mA
Dropout Voltage	V_D			2		V

■ ELECTRICAL CHARACTERISTICS (Cont.)

For 78D15 ($V_{IN}=23V$, $I_{OUT}=0.5A$, $C_I=0.33\mu F$, $C_O=0.1\mu F$)

PARAMETER	SYMBOL	TEST CONDITIONS	MIN	TYP	MAX	UNIT
Output Voltage	V_{OUT}	$I_{OUT}=5mA\sim 0.5A$	14.4	15	15.6	V
		$V_{IN}=17.5\sim 30V$, $I_{OUT}=5mA\sim 0.5A$	14.25		15.75	V
Load Regulation	ΔV_{OUT}	$I_{OUT}=5mA\sim 0.5A$			150	mV
		$I_{OUT}=5mA\sim 200mA$			75	mV
Line Regulation	ΔV_{OUT}	$V_{IN}=18.5\sim 30V$			150	mV
		$V_{IN}=17.5\sim 30V$, $I_{OUT}=0.5A$			150	mV
Quiescent Current	I_Q	$I_{OUT}=0.5A$			8	mA
Quiescent Current Change	ΔI_Q	$V_{IN}=17.5\sim 30V$			1	mA
		$I_{OUT}=5mA\sim 0.5A$			0.5	mA
Output Noise Voltage	eN	$10Hz\leq f\leq 100kHz$		90		μV
Ripple Rejection	RR	$V_{IN}=18.5\sim 28.5V$, $f=120Hz$	51	70		dB
Peak Output Current	I_{PEAK}			1.2		A
Short-Circuit Current	I_{SC}	$V_{IN}=V_{OUT}+19V$		250		mA
Dropout Voltage	V_D			2		V

For 78D18 ($V_{IN}=27V$, $I_{OUT}=0.5A$)

PARAMETER	SYMBOL	TEST CONDITIONS	MIN	TYP	MAX	UNIT
Output Voltage	V_{OUT}	$I_{OUT}=5mA\sim 0.5A$	17.28	18	18.72	V
		$V_{IN}=21\sim 33V$, $I_{OUT}=5mA\sim 0.5A$	17.1		18.9	V
Load Regulation	ΔV_{OUT}	$I_{OUT}=5mA\sim 0.5A$			180	mV
		$I_{OUT}=5mA\sim 200mA$			90	mV
Line Regulation	ΔV_{OUT}	$V_{IN}=21\sim 33V$			180	mV
		$V_{IN}=21\sim 33V$, $I_{OUT}=0.5A$			180	mV
Quiescent Current	I_Q	$I_{OUT}=0.5A$			8	mA
Quiescent Current Change	ΔI_Q	$V_{IN}=21.5\sim 33V$			1	mA
		$I_{OUT}=5mA\sim 0.5A$			0.5	mA
Output Noise Voltage	eN	$10Hz\leq f\leq 100kHz$		110		μV
Ripple Rejection	RR	$V_{IN}=22\sim 32V$, $f=120Hz$	50	69		dB
Peak Output Current	I_{PEAK}			1.2		A
Short-Circuit Current	I_{SC}	$V_{IN}=35V$		250		mA
Dropout Voltage	V_D			2		V

For 78D20 ($V_{IN}=29V$, $I_{OUT}=0.5A$)

PARAMETER	SYMBOL	TEST CONDITIONS	MIN	TYP	MAX	UNIT
Output Voltage	V_{OUT}	$I_{OUT}=5mA\sim 0.5A$	19.20	20.0	20.80	V
		$V_{IN}=23\sim 35V$, $I_{OUT}=5mA\sim 0.5A$	19.00		21.00	V
Load Regulation	ΔV_{OUT}	$I_{OUT}=5mA\sim 0.5A$			200	mV
		$I_{OUT}=5mA\sim 200mA$			100	mV
Line Regulation	ΔV_{OUT}	$V_{IN}=23\sim 35V$			200	mV
		$V_{IN}=23\sim 35V$, $I_{OUT}=0.5A$			200	mV
Quiescent Current	I_Q	$I_{OUT}\leq 0.5A$			8	mA
Quiescent Current Change	ΔI_Q	$V_{IN}=23.5\sim 35V$			1	mA
		$I_{OUT}=5mA\sim 0.5A$			0.5	mA
Output Noise Voltage	eN	$10Hz\leq f\leq 100kHz$		130		μV
Ripple Rejection	RR	$V_{IN}=24\sim 34V$, $f=120Hz$	49	68		dB
Peak Output Current	I_{PEAK}			1.2		A
Short-Circuit Current	I_{SC}	$V_{IN}=35V$		250		mA
Dropout Voltage	V_D			2.0		V

■ ELECTRICAL CHARACTERISTICS (Cont.)

For 78D24 ($V_{IN}=33V$, $I_{OUT}=0.5A$)

PARAMETER	SYMBOL	TEST CONDITIONS	MIN	TYP	MAX	UNIT
Output Voltage	V_{OUT}	$I_{OUT}=5mA\sim 0.5A$	23.04	24	24.96	V
		$V_{IN}=27\sim 38V$, $I_{OUT}=5mA\sim 0.5A$	22.8		25.2	V
Load Regulation	ΔV_{OUT}	$I_{OUT}=5mA\sim 0.5A$			240	mV
		$I_{OUT}=5mA\sim 200mA$			120	mV
Line Regulation	ΔV_{OUT}	$V_{IN}=27\sim 38V$			240	mV
		$V_{IN}=27\sim 38V$, $I_{OUT}=0.5A$			240	mV
Quiescent Current	I_Q	$I_{OUT}=0.5A$			8	mA
Quiescent Current Change	ΔI_Q	$V_{IN}=28\sim 38V$			1	mA
		$I_{OUT}=5mA\sim 0.5A$			0.5	mA
Output Noise Voltage	eN	$10Hz\leq f\leq 100kHz$		170		μV
Ripple Rejection	RR	$V_{IN}=28\sim 38V$, $f=120Hz$	47	66		dB
Peak Output Current	I_{PEAK}			1.2		A
Short-Circuit Current	I_{SC}	$V_{IN}=35V$		250		mA
Dropout Voltage	V_D			2		V

■ TYPICAL CHARACTERISTICS

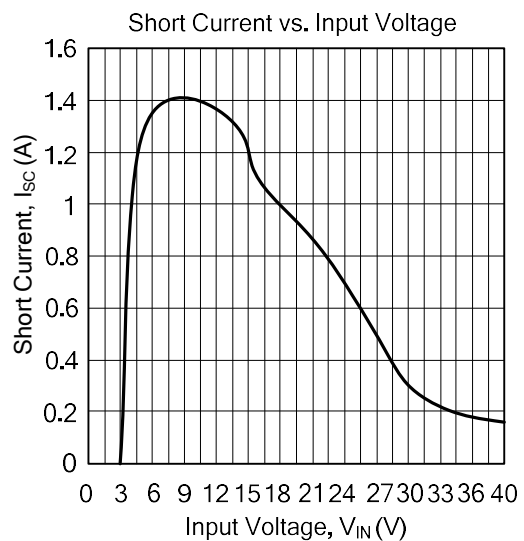
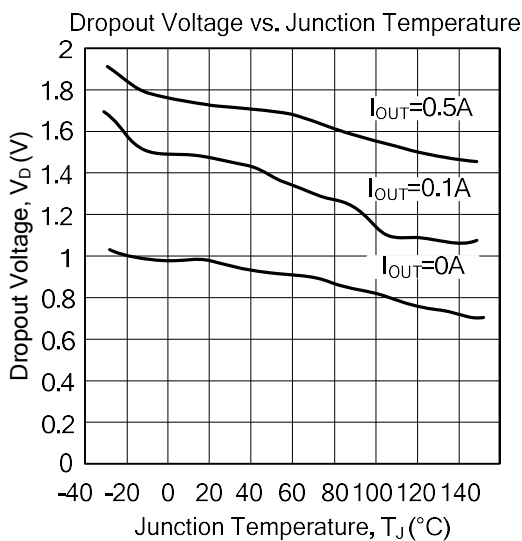
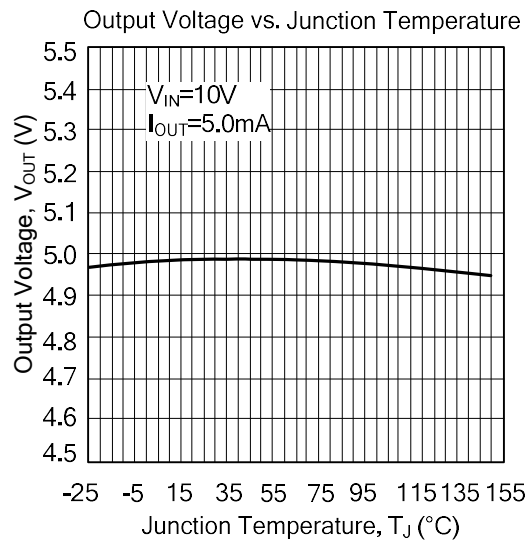
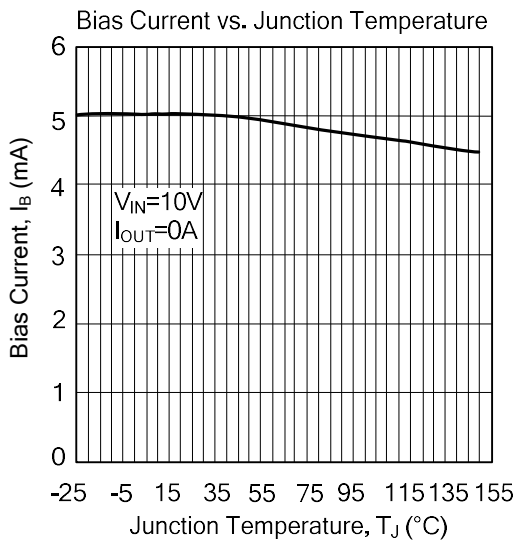
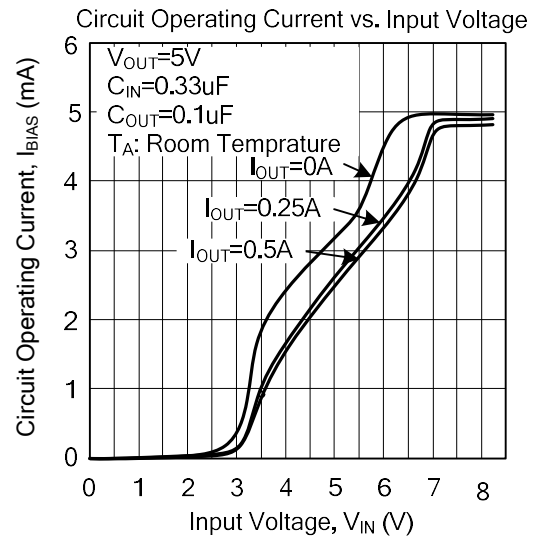
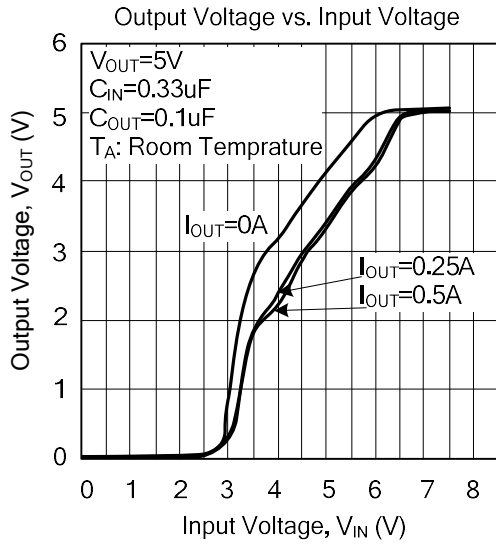

■ TYPICAL CHARACTERISTICS (Cont.)

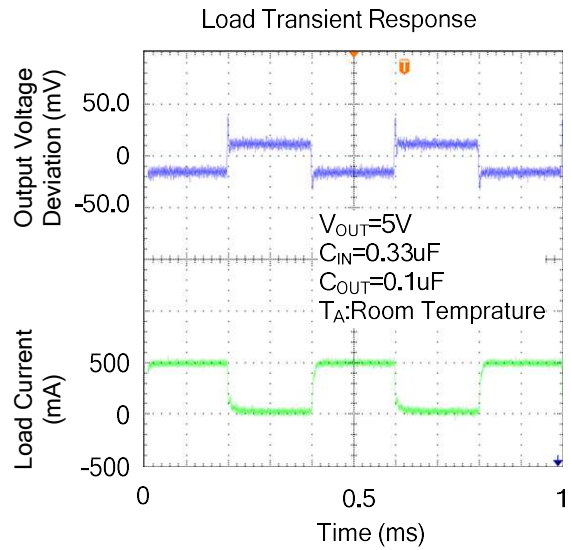
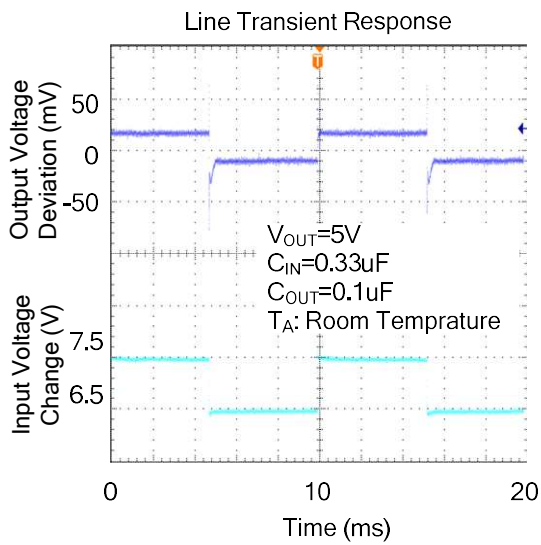

UTC assumes no responsibility for equipment failures that result from using products at values that exceed, even momentarily, rated values (such as maximum ratings, operating condition ranges, or other parameters) listed in products specifications of any and all UTC products described or contained herein. UTC products are not designed for use in life support appliances, devices or systems where malfunction of these products can be reasonably expected to result in personal injury. Reproduction in whole or in part is prohibited without the prior written consent of the copyright owner. UTC reserves the right to make changes to information published in this document, including without limitation specifications and product descriptions, at any time and without notice. This document supersedes and replaces all information supplied prior to the publication hereof.

X-ON Electronics

Largest Supplier of Electrical and Electronic Components

Click to view similar products for [Linear Voltage Regulators](#) category:

Click to view products by [Unisonic](#) manufacturer:

Other Similar products are found below :

[LV5684PVD-XH](#) [MCDTSA6-2R](#) [L7815ACV-DG](#) [LV56801P-E](#) [UA7805CKC](#) [714954EB](#) [ZMR500QFTA](#) [BA033LBSG2-TR](#)
[NCV78M05ABDTRKG](#) [LV5680P-E](#) [L79M05T-E](#) [L78LR05D-MA-E](#) [NCV317MBTG](#) [NTE7227](#) [MP2018GZD-33-P](#) [MP2018GZD-5-P](#)
[LV5680NPVC-XH](#) [ZTS6538SE](#) [UA78L09CLP](#) [UA78L09CLPR](#) [CAT6221-PPTD-GT3](#) [MC78M09CDTRK](#) [NCV51190MNTAG](#)
[BL1118CS8TR1833](#) [BL8077CKETR33](#) [BL9153-33CC3TR](#) [BL9161G-28BADRN](#) [BRCO7530MMC](#) [CJ7815B-TFN-ARG](#) [LM317C](#)
[GM7333K](#) [GM7350K](#) [XC6206P332MR](#) [HT7533](#) [LM7912S/TR](#) [LT1764S/TR](#) [LM7805T](#) [LM338T](#) [LM1117IMP-3.3/TR](#) [HT1117AM-3.3](#)
[HT7550S](#) [AMS1117-3.3](#) [HT7150S](#) [78L12](#) [HT7550](#) [HT7533-1](#) [HXY6206I-2.5](#) [HT7133](#) [HT7533S](#) [662K](#)