



78DXXL

LINEAR INTEGRATED CIRCUIT

3-TERMINALS 0.5A POSITIVE VOLTAGE REGULATOR

DESCRIPTION

The UTC **78DXXL** family is monolithic fixed voltage regulator integrated circuit. They are suitable for applications that required supply current up to 0.5 A.

FEATURE

- * Output Current Up To 0.5 A
- * Fixed Output Voltage Of 5V, 6V, 8V, 9V, 12V, 15V and 18V Available
- * Thermal Overload Shutdown Protection
- * Short Circuit Current Limiting
- * Output Transistor SOA Protection

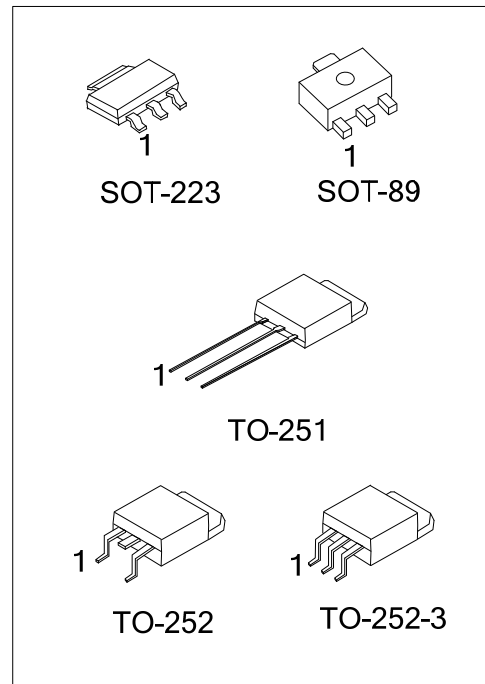

ORDERING INFORMATION

Ordering Number		Package	Pin Assignment			Packing
Lead Free	Halogen Free		1	2	3	
78DXXLL-AA3-R	78DXXLG-AA3-R	SOT-223	I	G	O	Tape Reel
78DXXLL-AB3-B-R	78DXXLG-AB3-B-R	SOT-89	O	G	I	Tape Reel
78DXXLL-TM3-T	78DXXLG-TM3-T	TO-251	I	G	O	Tube
78DXXLL-TN3-R	78DXXLG-TN3-R	TO-252	I	G	O	Tape Reel
78DXXLL-TNA-R	78DXXLG-TNA-R	TO-252-3	I	G	O	Tape Reel

Note: 1. XX: Output Voltage, refer to Marking Information
 2. Pin Code: I: Input G: GND O: Output

<p>78DXXLG-AB3-B-R</p>	<p>(1) Packing Type (2) refer to Pin Assignment (3) Package Type (4) Green Package (5) Output Voltage Code</p>	<p>(1) R: Tape Reel, T: Tube (2) refer to Pin Assignment (3) AA3: SOT-223, AB3: SOT-89, TM3: TO-251, TN3: TO-252, TNA: TO-252-3 (4) G: Halogen Free and Lead Free, L: Lead Free (5) XX: refer to Marking Information</p>
------------------------	--	--

MARKING INFORMATION

PACKAGE	VOLTAGE CODE	MARKING
SOT-223		
SOT-89	05: 5V 06: 6V 08: 8V 09: 9V 12: 12V 15: 15V 18: 18V	
TO-251 TO-252 TO-252-3		

■ BLOCK DIAGRAM

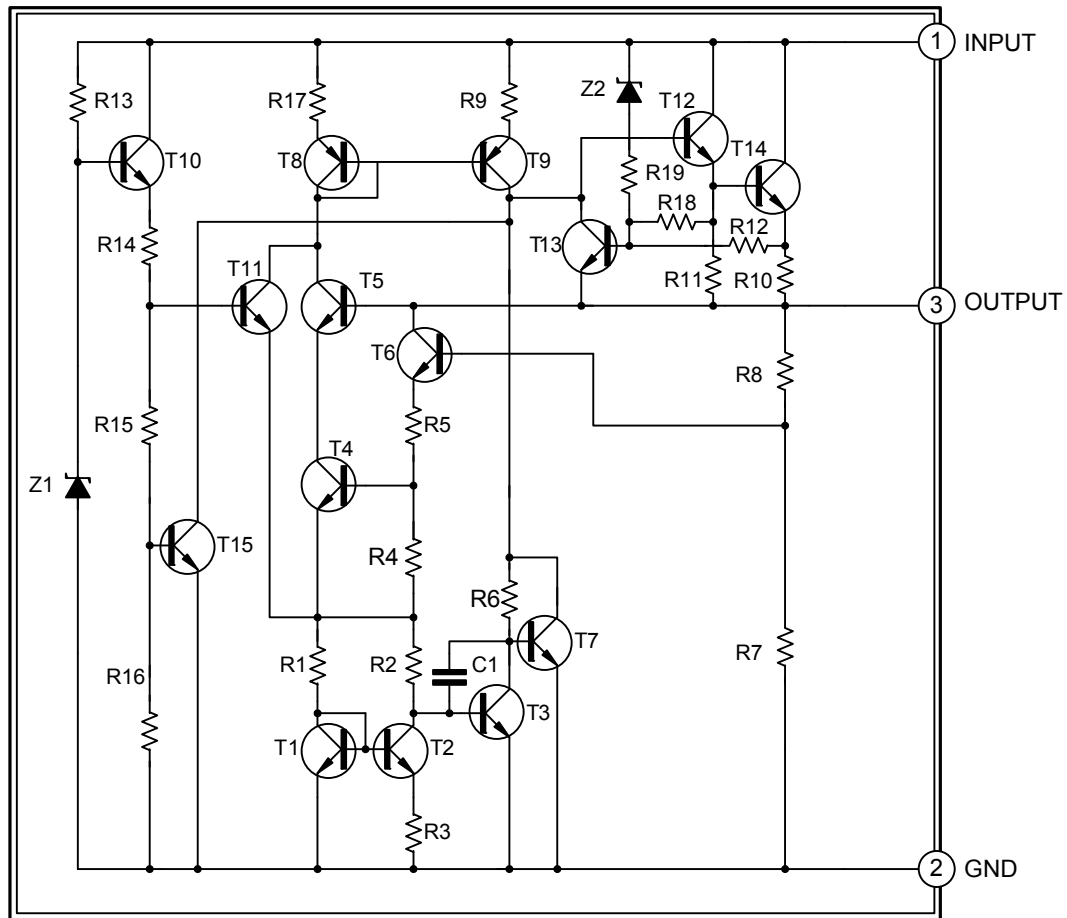

■ TYPICAL APPLICATION CIRCUIT

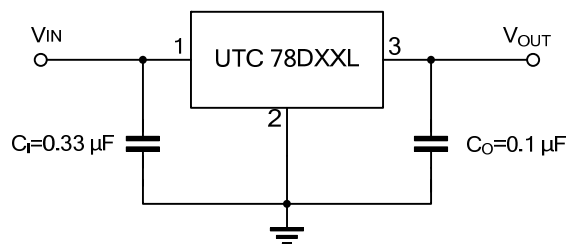

Note: Bypass capacitors are recommended for optimum stability and transient response and should be located as close as possible to the regulators.

■ ABSOLUTE MAXIMUM RATINGS ($T_J=25^{\circ}\text{C}$, unless otherwise specified)

PARAMETER	SYMBOL	RATINGS	UNIT
Input Voltage	V_{IN}	35	V
Output Current	I_{OUT}	0.5	A
Power Dissipation ($T_C=25^{\circ}\text{C}$)	SOT-223	8.3	W
	SOT-89	2.3	
	TO-251/TO-252	10	
Junction Temperature	T_J	-20~ +150	$^{\circ}\text{C}$
Storage Temperature	T_{STG}	-65 ~ +150	$^{\circ}\text{C}$

Notes: Absolute maximum ratings are those values beyond which the device could be permanently damaged.
Absolute maximum ratings are stress ratings only and functional device operation is not implied.

■ THERMAL DATA

PARAMETER	SYMBOL	RATINGS	UNIT
Junction to Case	SOT-223	15	$^{\circ}\text{C/W}$
	SOT-89	55	
	TO-251/TO-252	12.5	

■ ELECTRICAL CHARACTERISTICS

($T_J=25^{\circ}\text{C}$, $C_i=0.33\mu\text{F}$, $C_o=0.1\mu\text{F}$, $P_D\leq 7\text{W}$, unless otherwise specified)

For 78D05L ($V_{IN}=10\text{V}$, $I_{OUT}=0.5\text{A}$)

PARAMETER	SYMBOL	TEST CONDITIONS	MIN	TYP	MAX	UNIT
Output Voltage	V_{OUT}	$I_{OUT}=5\text{mA}\sim 0.5\text{A}$	4.8	5	5.2	V
		$V_{IN}=7.5\sim 20\text{V}$, $I_{OUT}=5\text{mA}\sim 0.5\text{A}$	4.75		5.25	V
Load Regulation	ΔV_{OUT}	$I_{OUT}=5\text{mA}\sim 0.5\text{A}$			100	mV
		$I_{OUT}=5\text{mA}\sim 200\text{mA}$			50	mV
Line Regulation	ΔV_{OUT}	$V_{IN}=7\text{V}\sim 25\text{V}$			100	mV
		$V_{IN}=7.5\sim 20\text{V}$, $I_{OUT}=0.5\text{A}$			100	mV
Quiescent Current	I_Q	$I_{OUT}=0.5\text{A}$			8	mA
Quiescent Current Change	ΔI_Q	$V_{UT}=7.5\sim 20\text{V}$			1	mA
		$I_{OUT}=5\text{mA}\sim 0.5\text{A}$			0.5	mA
Output Noise Voltage	e_N	$10\text{Hz}\leq f\leq 100\text{kHz}$		40		μV
Ripple Rejection	RR	$V_{IN}=8\sim 18\text{V}$, $f=120\text{Hz}$	59	80		dB
Peak Output Current	I_{PEAK}			1.2		A
Short-Circuit Current	I_{SC}	$V_{IN}=V_{OUT}+19\text{V}$		250		mA
Dropout Voltage	V_D			2		V

■ ELECTRICAL CHARACTERISTICS (Cont.)

For 78D06L ($V_{IN}=11V$, $I_{OUT}=0.5A$)

PARAMETER	SYMBOL	TEST CONDITIONS	MIN	TYP	MAX	UNIT
Output Voltage	V_{OUT}	$I_{OUT}=5mA\sim 0.5A$	5.76	6	6.24	V
		$V_{IN}=8.5\sim 21V, I_{OUT}=5mA\sim 0.5A$	5.7		6.3	V
Load Regulation	ΔV_{OUT}	$I_{OUT}=5mA\sim 0.5A$			120	mV
		$I_{OUT}=5mA\sim 200mA$			60	mV
Line Regulation	ΔV_{OUT}	$V_{IN}=8\sim 25V$			120	mV
		$V_{IN}=8.5\sim 21V, I_{OUT}=0.5A$			120	mV
Quiescent Current	I_Q	$I_{OUT}=0.5A$			8	mA
Quiescent Current Change	ΔI_Q	$V_{IN}=8.5\sim 21V$			1	mA
		$I_{OUT}=5mA\sim 0.5A$			0.5	mA
Output Noise Voltage	e_N	$10Hz\leq f\leq 100kHz$		45		μV
Ripple Rejection	RR	$V_{IN}=9\sim 19V, f=120Hz$	56	75		dB
Peak Output Current	I_{PEAK}			1.2		A
Short-Circuit Current	I_{SC}	$V_{IN}=V_{OUT}+19V$		250		mA
Dropout Voltage	V_D			2		V

For 78D08L ($V_{IN}=14V$, $I_{OUT}=0.5A$)

PARAMETER	SYMBOL	TEST CONDITIONS	MIN	TYP	MAX	UNIT
Output Voltage	V_{OUT}	$I_{OUT}=5mA\sim 0.5A$	7.68	8	8.32	V
		$V_{IN}=10.5\sim 23V, I_{OUT}=5mA\sim 0.5A$	7.6		8.4	V
Load Regulation	ΔV_{OUT}	$I_{OUT}=5mA\sim 0.5A$			160	mV
		$I_{OUT}=5mA\sim 200mA$			80	mV
Line Regulation	ΔV_{OUT}	$V_{IN}=10.5\sim 25V$			160	mV
		$V_{IN}=10.5\sim 23V, I_{OUT}=0.5A$			160	mV
Quiescent Current	I_Q	$I_{OUT}=0.5A$			8	mA
Quiescent Current Change	ΔI_Q	$V_{IN}=10.5\sim 23V$			1	mA
		$I_{OUT}=5mA\sim 0.5A$			0.5	mA
Output Noise Voltage	e_N	$10Hz\leq f\leq 100kHz$		58		μV
Ripple Rejection	RR	$V_{IN}=11.5\sim 21.5V, f=120Hz$	53	72		dB
Peak Output Current	I_{PEAK}			1.2		A
Short-Circuit Current	I_{SC}	$V_{IN}=V_{OUT}+19V$		250		mA
Dropout Voltage	V_D			2		V

For 78D09L ($V_{IN}=15V$, $I_{OUT}=0.5A$)

PARAMETER	SYMBOL	TEST CONDITIONS	MIN	TYP	MAX	UNIT
Output Voltage	V_{OUT}	$I_{OUT}=5mA\sim 0.5A$	8.64	9	9.36	V
		$V_{IN}=11.5\sim 24V, I_{OUT}=5mA\sim 0.5A$	8.55		9.45	V
Load Regulation	ΔV_{OUT}	$I_{OUT}=5mA\sim 0.5A$			180	mV
		$I_{OUT}=5mA\sim 200mA$			90	mV
Line Regulation	ΔV_{OUT}	$V_{IN}=11.5\sim 25V$			180	mV
		$V_{IN}=11.5\sim 24V, I_{OUT}=0.5A$			180	mV
Quiescent Current	I_Q	$I_{OUT}=0.5A$			8	mA
Quiescent Current Change	ΔI_Q	$V_{IN}=11.5\sim 24V$			1	mA
		$I_{OUT}=5mA\sim 0.5A$			0.5	mA
Output Noise Voltage	e_N	$10Hz\leq f\leq 100kHz$		58		μV
Ripple Rejection	RR	$V_{IN}=12.5\sim 22.5V, f=120Hz$	53	72		dB
Peak Output Current	I_{PEAK}			1.2		A
Short-Circuit Current	I_{SC}	$V_{IN}=V_{OUT}+19V$		250		mA
Dropout Voltage	V_D			2		V

■ ELECTRICAL CHARACTERISTICS (Cont.)

For 78D12L ($V_{IN}=19V$, $I_{OUT}=0.5A$)

PARAMETER	SYMBOL	TEST CONDITIONS	MIN	TYP	MAX	UNIT
Output Voltage	V_{OUT}	$I_{OUT}=5mA\sim 0.5A$	11.52	12	12.48	V
		$V_{IN}=14.5\sim 27V, I_{OUT}=5mA\sim 0.5A$	11.4		12.6	V
Load Regulation	ΔV_{OUT}	$I_{OUT}=5mA\sim 0.5A$			240	mV
		$I_{OUT}=5mA\sim 200mA$			120	mV
Line Regulation	ΔV_{OUT}	$V_{IN}=14.5\sim 30V$			240	mV
		$V_{IN}=14.6\sim 27V, I_{OUT}=0.5A$			240	mV
Quiescent Current	I_Q	$I_{OUT}=0.5A$			8	mA
Quiescent Current Change	ΔI_Q	$V_{IN}=14.5\sim 30V$			1	mA
		$I_{OUT}=5mA\sim 0.5A$			0.5	mA
Output Noise Voltage	e_N	$10Hz \leq f \leq 100kHz$		75		μV
Ripple Rejection	RR	$V_{IN}=15\sim 25V, f=120Hz$	52	72		dB
Peak Output Current	I_{PEAK}			1.2		A
Short-Circuit Current	I_{SC}	$V_{IN}=V_{OUT}+19V$		250		mA
Dropout Voltage	V_D			2		V

For 78D15L ($V_{IN}=23V$, $I_{OUT}=0.5A$, $C_I=0.33\mu F$, $C_O=0.1\mu F$)

PARAMETER	SYMBOL	TEST CONDITIONS	MIN	TYP	MAX	UNIT
Output Voltage	V_{OUT}	$I_{OUT}=5mA\sim 0.5A$	14.4	15	15.6	V
		$V_{IN}=17.5\sim 30V, I_{OUT}=5mA\sim 0.5A$	14.25		15.75	V
Load Regulation	ΔV_{OUT}	$I_{OUT}=5mA\sim 0.5A$			300	mV
		$I_{OUT}=5mA\sim 200mA$			150	mV
Line Regulation	ΔV_{OUT}	$V_{IN}=18.5\sim 30V$			300	mV
		$V_{IN}=17.5\sim 30V, I_{OUT}=0.5A$			300	mV
Quiescent Current	I_Q	$I_{OUT}=0.5A$			8	mA
Quiescent Current Change	ΔI_Q	$V_{IN}=17.5\sim 30V$			1	mA
		$I_{OUT}=5mA\sim 0.5A$			0.5	mA
Output Noise Voltage	e_N	$10Hz \leq f \leq 100kHz$		90		μV
Ripple Rejection	RR	$V_{IN}=18.5\sim 28.5V, f=120Hz$	51	70		dB
Peak Output Current	I_{PEAK}			1.2		A
Short-Circuit Current	I_{SC}	$V_{IN}=V_{OUT}+19V$		250		mA
Dropout Voltage	V_D			2		V

For 78D18L ($V_{IN}=27V$, $I_{OUT}=0.5A$)

PARAMETER	SYMBOL	TEST CONDITIONS	MIN	TYP	MAX	UNIT
Output Voltage	V_{OUT}	$I_{OUT}=5mA\sim 0.5A$	17.28	18	18.72	V
		$V_{IN}=21\sim 33V, I_{OUT}=5mA\sim 0.5A$	17.1		18.9	V
Load Regulation	ΔV_{OUT}	$I_{OUT}=5mA\sim 0.5A$			360	mV
		$I_{OUT}=5mA\sim 200mA$			180	mV
Line Regulation	ΔV_{OUT}	$V_{IN}=21\sim 33V$			360	mV
		$V_{IN}=21\sim 33V, I_{OUT}=0.5A$			360	mV
Quiescent Current	I_Q	$I_{OUT}=0.5A$			8	mA
Quiescent Current Change	ΔI_Q	$V_{IN}=21.5\sim 33V$			1	mA
		$I_{OUT}=5mA\sim 0.5A$			0.5	mA
Output Noise Voltage	e_N	$10Hz \leq f \leq 100kHz$		110		μV
Ripple Rejection	RR	$V_{IN}=22\sim 32V, f=120Hz$	50	69		dB
Peak Output Current	I_{PEAK}			1.2		A
Short-Circuit Current	I_{SC}	$V_{IN}=35V$		250		mA
Dropout Voltage	V_D			2		V

TYPICAL CHARACTERISTICS

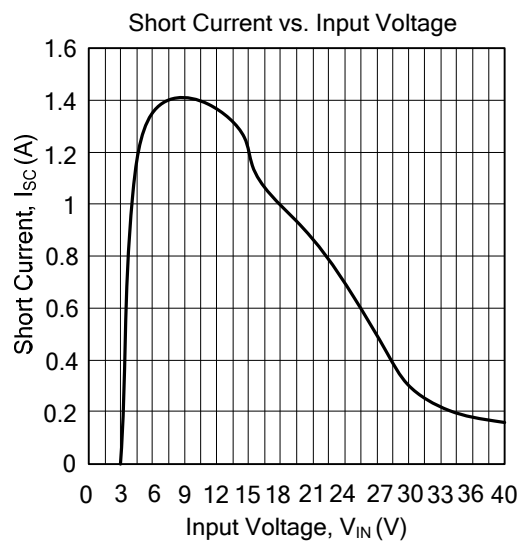
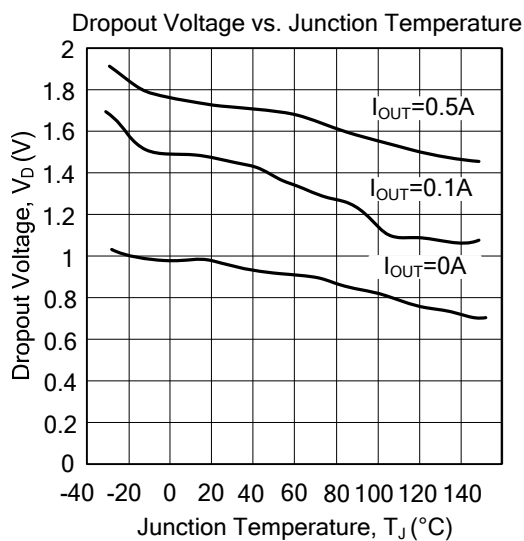
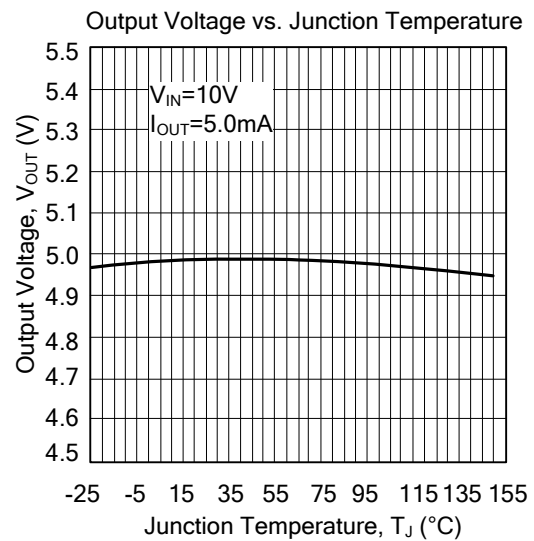
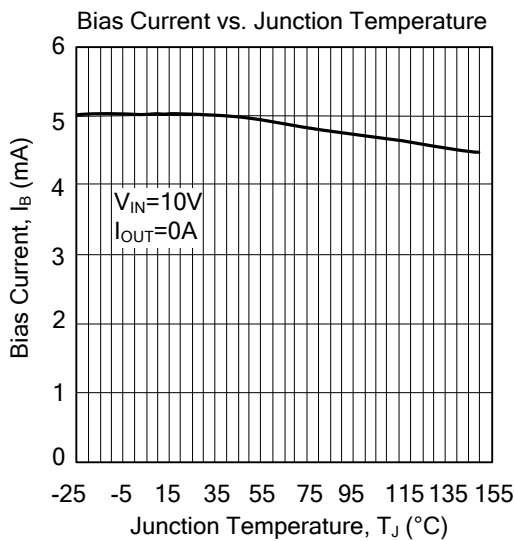
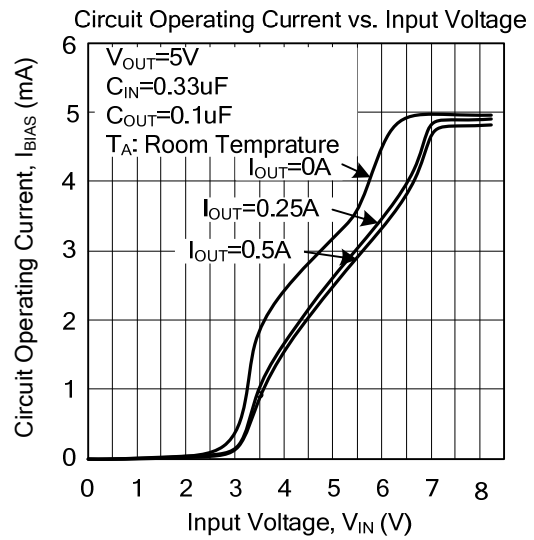
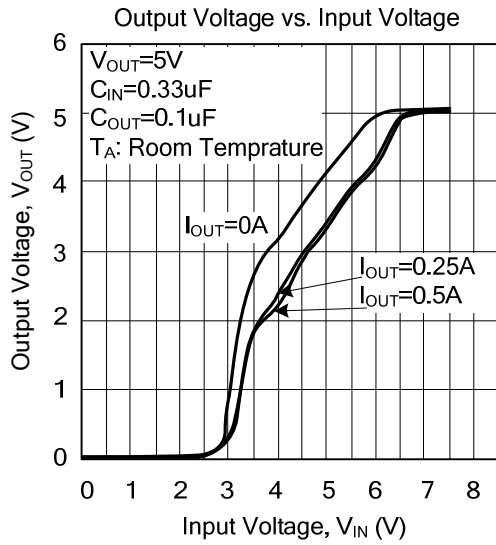

UTC assumes no responsibility for equipment failures that result from using products at values that exceed, even momentarily, rated values (such as maximum ratings, operating condition ranges, or other parameters) listed in products specifications of any and all UTC products described or contained herein. UTC products are not designed for use in life support appliances, devices or systems where malfunction of these products can be reasonably expected to result in personal injury. Reproduction in whole or in part is prohibited without the prior written consent of the copyright owner. UTC reserves the right to make changes to information published in this document, including without limitation specifications and product descriptions, at any time and without notice. This document supersedes and replaces all information supplied prior to the publication hereof.

X-ON Electronics

Largest Supplier of Electrical and Electronic Components

Click to view similar products for [Linear Voltage Regulators](#) category:

Click to view products by [Unisonic](#) manufacturer:

Other Similar products are found below :

[LV56831P-E](#) [LV5684PVD-XH](#) [MCDTSA6-2R](#) [L4953G](#) [L7815ACV-DG](#) [PQ3DZ53U](#) [LV56801P-E](#) [TCR3DF13,LM\(CT](#)

[TCR3DF39,LM\(CT](#) [TLE42794G](#) [L78L05CZ/1SX](#) [L78LR05DL-MA-E](#) [L78MR05-E](#) [033150D](#) [033151B](#) [090756R](#) [636416C](#)

[NCV78M15BDTG](#) [702482B](#) [714954EB](#) [TLE42794GM](#) [TLE42994GM](#) [ZMR500QFTA](#) [BA033LBSG2-TR](#) [NCV78M05ABDTRKG](#)

[NCV78M08BDTRKG](#) [NCP7808TG](#) [NCV571SN12T1G](#) [LV5680P-E](#) [CAJ24C256YI-GT3](#) [L78M15CV-DG](#) [L9474N](#)

[TLS202B1MBV33HTSA1](#) [L79M05T-E](#) [NCP571SN09T1G](#) [MAX15006AASA/V+](#) [MIC5283-5.0YML-T5](#) [L4969URTR-E](#) [L78LR05D-MA-E](#)

[NCV7808BDTRKG](#) [L9466N](#) [NCP7805ETG](#) [SC7812CTG](#) [NCV7809BTG](#) [NCV571SN09T1G](#) [NCV317MBTG](#) [MC78M15CDTT5G](#)

[MC78M12CDTT5G](#) [L9468N](#) [LT1054IS8#TRPBF](#)