



78LXXM

LINEAR INTEGRATED CIRCUIT

3-TERMINAL 0.2A POSITIVE VOLTAGE REGULATOR

■ DESCRIPTION

The UTC **78LXXM** family is monolithic fixed voltage regulator integrated circuit. They are suitable for applications that required supply current up to 200mA.

■ FEATURES

- *Output Current up to 200mA
- *Fixed Output Voltage of 5V, 6V, 8V, 9V, 10V, 12V, 15V, 18V and 24V Available
- *Thermal Overload Shutdown Protection
- *Short Circuit Current Limiting

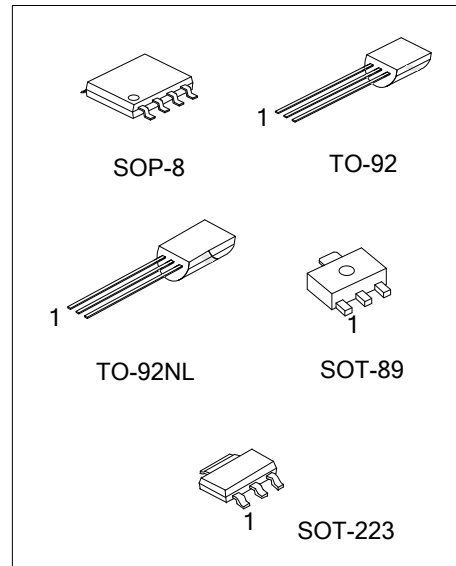

■ ORDERING INFORMATION

Ordering Number		Package	Pin Assignment								Packing
Lead Free	Halogen Free		1	2	3	4	5	6	7	8	
78LXXML-AA3-R	78LXXMG-AA3-R	SOT-223	O	G	I	-	-	-	-	-	Tape Reel
78LXXML-AB3-R	78LXXMG-AB3-R	SOT-89	O	G	I	-	-	-	-	-	Tape Reel
78LXXML-T92-B	78LXXMG-T92-B	TO-92	O	G	I	-	-	-	-	-	Tape Box
78LXXML-T92-K	78LXXMG-T92-K	TO-92	O	G	I	-	-	-	-	-	Bulk
78LXXML-T9N-B	78LXXMG-T9N-B	TO-92NL	O	G	I	-	-	-	-	-	Tape Box
78LXXML-T9N-K	78LXXMG-T9N-K	TO-92NL	O	G	I	-	-	-	-	-	Bulk
78LXXML-S08-R	78LXXMG-S08-R	SOP-8	O	G	G	NC	NC	G	G	I	Tape Reel

Notes: 1. XX: Output Voltage, refer to Marking Information
 2. Pin Assignment: O: Output G: GND I: Input

<p>78LXXMG-AA3-R</p>	<p>(1) Packing Type (2) Package Type (3) Green Package (4) Output Voltage Code</p>	<p>(1) B: Tape Box, K: Bulk, R: Tape Reel (2) AA3: SOT-223, AB3: SOT-89, S08: SOP-8, T92: TO-92, T9N: TO-92NL (3) G: Halogen Free and Lead Free, L: Lead Free (4) xx: refer to Marking Information</p>
----------------------	---	---

MARKING INFORMATION

PACKAGE	VOLTAGE CODE	MARKING
SOT-223	05:5.0V 06:6.0V 08:8.0V 09:9.0V 10:10V 12:12V 15:15V 18:18V 24:24V	
SOP-8		
SOT-89		
TO-92		
TO-92NL		

■ ABSOLUTE MAXIMUM RATINGS

(Operating temperature range applies unless otherwise specified.)

PARAMETER	SYMBOL	RATINGS	UNIT
Input Voltage	V_{IN}	30	V
		35	V
Output Current	I_{OUT}	200	mA
Power Dissipation	P_D	500	mW
		625	
		800	
		800	
		350	
		750	
Junction Temperature	T_J	+150	°C
Ambient Operating Temperature	T_{OPR}	-40 ~ +125	°C
Storage Temperature	T_{STG}	-55 ~ +150	°C

Note Absolute maximum ratings are those values beyond which the device could be permanently damaged. Absolute maximum ratings are stress ratings only and functional device operation is not implied.

■ ELECTRICAL CHARACTERISTICS

(0°C < T_J < 125°C, $C_1=0.33\mu\text{F}$, $C_0=0.1\mu\text{F}$, unless otherwise specified) (Note 1)

For UTC78L05M ($V_{IN}=10\text{V}$, $I_{OUT}=40\text{mA}$)

PARAMETER	SYMBOL	TEST CONDITIONS	MIN	TYP	MAX	UNIT
Output Voltage	V_{OUT}	$T_J=25^\circ\text{C}$	4.80	5.0	5.20	V
		$7\text{V} \leq V_{IN} \leq 20\text{V}, I_{OUT}=1\text{mA} \sim 40\text{mA}$	4.75		5.25	V
		$7\text{V} \leq V_{IN} \leq V_{MAX}$ $I_{OUT}=1\text{mA} \sim 200\text{mA}$	4.75		5.25	V (Note 2)
Load Regulation	ΔV_{OUT}	$T_J=25^\circ\text{C}, I_{OUT}=1\text{mA} \sim 100\text{mA}$		15	60	mV
		$T_J=25^\circ\text{C}, I_{OUT}=1\text{mA} \sim 40\text{mA}$		8	30	mV
Line Regulation	ΔV_{OUT}	$7\text{V} \leq V_{IN} \leq 20\text{V}, T_J=25^\circ\text{C}$		8	150	mV
		$8\text{V} \leq V_{IN} \leq 20\text{V}, T_J=25^\circ\text{C}$		6	100	mV
Quiescent Current	I_Q			2.0	5.5	mA
Quiescent Current Change	ΔI_Q	$8\text{V} \leq V_{IN} \leq 20\text{V}$			1.5	mA
		$1\text{mA} \leq V_{IN} \leq 40\text{mA}$			0.1	mA
Output Noise Voltage	e_N	$10\text{Hz} \leq f \leq 100\text{kHz}$		40		μV
Temperature Coefficient of V_{OUT}	$\Delta V_O/\Delta T$	$I_{OUT}=5\text{mA}$		-0.65		$\text{mV}/^\circ\text{C}$
Ripple Rejection	RR	$8\text{V} \leq V_{IN} \leq 20\text{V}, f=120\text{Hz}, T_J=25^\circ\text{C}$		60		dB
Dropout Voltage	V_D	$T_J=25^\circ\text{C}$		1.7		V

■ ELECTRICAL CHARACTERISTICS (Cont.)

For UTC78L06M ($V_{IN}=12V$, $I_{OUT}=40mA$)

PARAMETER	SYMBOL	TEST CONDITIONS	MIN	TYP	MAX	UNIT
Output Voltage	V_{OUT}	$T_J=25^\circ C$	5.76	6.0	6.24	V
		$8.5V \leq V_{IN} \leq 20V, I_{OUT}=1mA \sim 40mA$	5.7		6.3	V
		$8.5V \leq V_{IN} \leq V_{MAX},$ $I_{OUT}=1mA - 200mA$	5.7		6.3	V (Note 2)
Load Regulation	ΔV_{OUT}	$T_J=25^\circ C, I_{OUT}=1mA \sim 100mA$		16	80	mV
		$T_J=25^\circ C, I_{OUT}=1mA \sim 70mA$		9	40	mV
Line Regulation	ΔV_{OUT}	$8.5V \leq V_{IN} \leq 20V, T_J=25^\circ C$		10	175	mV
		$9V \leq V_{IN} \leq 20V, T_J=25^\circ C$		8	125	mV
Quiescent Current	I_Q			2.0	5.5	mA
Quiescent Current Change	ΔI_Q	$9V \leq V_{IN} \leq 20V$			1.5	mA
		$1mA \leq V_{IN} \leq 40mA$			0.1	mA
Output Noise Voltage	e_N	$10Hz \leq f \leq 100kHz$		49		μV
Temperature Coefficient of V_{OUT}	$\Delta V_O/\Delta T$	$I_{OUT}=5mA$		-0.75		mV/ $^\circ C$
Ripple Rejection	RR	$10V \leq V_{IN} \leq 20V, f=120Hz, T_J=25^\circ C$		56		dB
Dropout Voltage	V_D	$T_J=25^\circ C$		1.7		V

For UTC78L08M ($V_{IN}=14V$, $I_{OUT}=40mA$)

PARAMETER	SYMBOL	TEST CONDITIONS	MIN	TYP	MAX	UNIT
Output Voltage	V_{OUT}	$T_J=25^\circ C$	7.68	8.0	8.32	V
		$10.5V \leq V_{IN} \leq 23V, I_{OUT}=1mA \sim 40mA$	7.60		8.40	V
		$10.5V \leq V_{IN} \leq V_{MAX},$ $I_{OUT}=1mA - 200mA$	7.60		8.40	V (Note 2)
Load Regulation	ΔV_{OUT}	$T_J=25^\circ C, I_{OUT}=1mA \sim 100mA$		18	80	mV
		$T_J=25^\circ C, I_{OUT}=1mA \sim 70mA$		10	40	mV
Line Regulation	ΔV_{OUT}	$10.5V \leq V_{IN} \leq 23V, T_J=25^\circ C$		12	175	mV
		$11V \leq V_{IN} \leq 23V, T_J=25^\circ C$		10	125	mV
Quiescent Current	I_Q			2.0	5.5	mA
Quiescent Current Change	ΔI_Q	$11V \leq V_{IN} \leq 23V$			1.5	mA
		$1mA \leq V_{IN} \leq 40mA$			0.1	mA
Output Noise Voltage	e_N	$10Hz \leq f \leq 100kHz$		49		μV
Temperature Coefficient of V_{OUT}	$\Delta V_O/\Delta T$	$I_{OUT}=5mA$		-0.75		mV/ $^\circ C$
Ripple Rejection	RR	$11V \leq V_{IN} \leq 23V, f=120Hz, T_J=25^\circ C$		52		dB
Dropout Voltage	V_D	$T_J=25^\circ C$		1.7		V

For UTC78L09M ($V_{IN}=15V$, $I_{OUT}=40mA$)

PARAMETER	SYMBOL	TEST CONDITIONS	MIN	TYP	MAX	UNIT
Output Voltage	V_{OUT}	$T_J=25^\circ C$	8.64	9.0	9.36	V
		$11.5V \leq V_{IN} \leq 24V, I_{OUT}=1mA \sim 40mA$	8.55		9.45	V
		$11.5V \leq V_{IN} \leq V_{MAX},$ $I_{OUT}=1mA - 200mA$	8.55		9.45	V (Note 2)
Load Regulation	ΔV_{OUT}	$T_J=25^\circ C, I_{OUT}=1mA \sim 100mA$		20	90	mV
		$T_J=25^\circ C, I_{OUT}=1mA \sim 40mA$		10	45	mV
Line Regulation	ΔV_{OUT}	$11.5V \leq V_{IN} \leq 24V, T_J=25^\circ C$		15	200	mV
		$13V \leq V_{IN} \leq 24V, T_J=25^\circ C$		10	150	mV
Quiescent Current	I_Q			2.0	6.0	mA
Quiescent Current Change	ΔI_Q	$13V \leq V_{IN} \leq 24V$			1.5	mA
		$1mA \leq V_{IN} \leq 40mA$			0.1	mA
Output Noise Voltage	e_N	$10Hz \leq f \leq 100kHz$		70		μV
Temperature Coefficient of V_{OUT}	$\Delta V_O/\Delta T$	$I_{OUT}=5mA$		-0.75		mV/ $^\circ C$
Ripple Rejection	RR	$12V \leq V_{IN} \leq 24V, f=120Hz, T_J=25^\circ C$		46		dB
Dropout Voltage	V_D	$T_J=25^\circ C$		1.7		V

■ ELECTRICAL CHARACTERISTICS(Cont.)

For UTC78L10M ($V_{IN}=16V$, $I_{OUT}=40mA$)

PARAMETER	SYMBOL	TEST CONDITIONS	MIN	TYP	MAX	UNIT
Output Voltage	V_{OUT}	$T_J=25^{\circ}C$	9.6	10.0	10.4	V
		$12.5V \leq V_{IN} \leq 23V, I_{OUT}=1mA \sim 40mA$	9.5		10.5	V
		$12.5V \leq V_{IN} \leq V_{MAX},$ $I_{OUT}=1mA - 200mA$	9.5		10.5	V (Note 2)
Load Regulation	ΔV_{OUT}	$T_J=25^{\circ}C, I_{OUT}=1mA \sim 100mA$		20	90	mV
		$T_J=25^{\circ}C, I_{OUT}=1mA \sim 70mA$		10	45	mV
Line Regulation	ΔV_{OUT}	$12.5V \leq V_{IN} \leq 25V, T_J=25^{\circ}C$		25	200	mV
		$14V \leq V_{IN} \leq 25V, T_J=25^{\circ}C$		20	170	mV
Quiescent Current	I_Q			2.0	6.0	mA
Quiescent Current Change	ΔI_Q	$12.5V \leq V_{IN} \leq 25V$			1.5	mA
		$1mA \leq V_{IN} \leq 40mA$			0.1	mA
Output Noise Voltage	e_N	$10Hz \leq f \leq 100kHz$		74		μV
Temperature Coefficient of V_{OUT}	$\Delta V_O/\Delta T$	$I_{OUT}=5mA$		-0.8		$mV/^{\circ}C$
Ripple Rejection	RR	$15V \leq V_{IN} \leq 25V, f=120Hz, T_J=25^{\circ}C$		45		dB
Dropout Voltage	V_D	$T_J=25^{\circ}C$		1.7		V

For UTC78L12M ($V_{IN}=19V$, $I_{OUT}=40mA$)

PARAMETER	SYMBOL	TEST CONDITIONS	MIN	TYP	MAX	UNIT
Output Voltage	V_{OUT}	$T_J=25^{\circ}C$	11.52	12	12.48	V
		$14.5V \leq V_{IN} \leq 27V, I_{OUT}=1mA \sim 40mA$	11.40		12.60	V
		$14.5V \leq V_{IN} \leq V_{MAX},$ $I_{OUT}=1mA - 200mA$	11.40		12.60	V (Note 2)
Load Regulation	ΔV_{OUT}	$T_J=25^{\circ}C, I_{OUT}=1mA \sim 100mA$		25	100	mV
		$T_J=25^{\circ}C, I_{OUT}=1mA \sim 40mA$		12	50	mV
Line Regulation	ΔV_{OUT}	$14.5V \leq V_{IN} \leq 27V, T_J=25^{\circ}C$		25	300	mV
		$16V \leq V_{IN} \leq 27V, T_J=25^{\circ}C$		20	250	mV
Quiescent Current	I_Q			2.0	6.5	mA
Quiescent Current Change	ΔI_Q	$16V \leq V_{IN} \leq 27V$			1.5	mA
		$1mA \leq V_{IN} \leq 40mA$			0.1	mA
Output Noise Voltage	e_N	$10Hz \leq f \leq 100kHz$		80		μV
Temperature Coefficient of V_{OUT}	$\Delta V_O/\Delta T$	$I_{OUT}=5mA$		-1.0		$mV/^{\circ}C$
Ripple Rejection	RR	$15V \leq V_{IN} \leq 25V, f=120Hz, T_J=25^{\circ}C$		45		dB
Dropout Voltage	V_D	$T_J=25^{\circ}C$		1.7		V

For UTC78L15M ($V_{IN}=23V$, $I_{OUT}=40mA$)

PARAMETER	SYMBOL	TEST CONDITIONS	MIN	TYP	MAX	UNIT
Output Voltage	V_{OUT}	$T_J=25^{\circ}C$	14.40	15	15.60	V
		$17.5V \leq V_{IN} \leq 30V, I_{OUT}=1mA \sim 40mA$	14.25		15.75	V
		$17.5V \leq V_{IN} \leq V_{MAX},$ $I_{OUT}=1mA - 200mA$	14.25		15.75	V (Note 2)
Load Regulation	ΔV_{OUT}	$T_J=25^{\circ}C, I_{OUT}=1mA \sim 100mA$		25	150	mV
		$T_J=25^{\circ}C, I_{OUT}=1mA \sim 70mA$		15	75	mV
Line Regulation	ΔV_{OUT}	$17.5V \leq V_{IN} \leq 30V, T_J=25^{\circ}C$		25	150	mV
		$20V \leq V_{IN} \leq 30V, T_J=25^{\circ}C$		15	75	mV
Quiescent Current	I_Q			2.2	6.5	mA
Quiescent Current Change	ΔI_Q	$20V \leq V_{IN} \leq 30V$			1.5	mA
		$1mA \leq V_{IN} \leq 40mA$			0.1	mA
Output Noise Voltage	e_N	$10Hz \leq f \leq 100kHz$		90		μV
Temperature Coefficient of V_{OUT}	$\Delta V_O/\Delta T$	$I_{OUT}=5mA$		-1.3		$mV/^{\circ}C$
Ripple Rejection	RR	$18.5V \leq V_{IN} \leq 28.5V, f=120Hz, T_J=25^{\circ}C$		45		dB
Dropout Voltage	V_D	$T_J=25^{\circ}C$		1.7		V

■ ELECTRICAL CHARACTERISTICS (Cont.)

For UTC78L18M ($V_{IN}=27V$, $I_{OUT}=40mA$)

PARAMETER	SYMBOL	TEST CONDITIONS	MIN	TYP	MAX	UNIT
Output Voltage	V_{OUT}	$T_J=25^{\circ}C$	17.28	18	18.72	V
		$21V \leq V_{IN} \leq 33V, I_{OUT}=1mA \sim 40mA$	17.10		18.90	V
		$21V \leq V_{IN} \leq V_{MAX}, I_{OUT}=1mA - 200mA$	17.10		18.90	V (Note 2)
Load Regulation	ΔV_{OUT}	$T_J=25^{\circ}C, I_{OUT}=1mA \sim 100mA$		30	180	mV
		$T_J=25^{\circ}C, I_{OUT}=1mA \sim 40mA$		20	90	mV
Line Regulation	ΔV_{OUT}	$21V \leq V_{IN} \leq 33V, T_J=25^{\circ}C$		45	300	mV
		$22V \leq V_{IN} \leq 33V, T_J=25^{\circ}C$		35	250	mV
Quiescent Current	I_Q			2.2	6.5	mA
Quiescent Current Change	ΔI_Q	$21V \leq V_{IN} \leq 33V$			1.5	mA
		$1mA \leq V_{IN} \leq 40mA$			0.1	mA
Output Noise Voltage	e_N	$10Hz \leq f \leq 100kHz$		150		μV
Temperature Coefficient of V_{OUT}	$\Delta V_O/\Delta T$	$I_{OUT}=5mA$		-1.8		$mV/^{\circ}C$
Ripple Rejection	RR	$23V \leq V_{IN} \leq 28.5V, f=120Hz, T_J=25^{\circ}C$		45		dB
Dropout Voltage	V_D	$T_J=25^{\circ}C$		1.7		V

For UTC78L24M ($V_{IN}=33V$, $I_{OUT}=40mA$)

PARAMETER	SYMBOL	TEST CONDITIONS	MIN	TYP	MAX	UNIT
Output Voltage	V_{OUT}	$T_J=25^{\circ}C$	23.04	24	24.96	V
		$27V \leq V_{IN} \leq 35V, I_{OUT}=1mA \sim 40mA$	22.80		25.20	V
		$27V \leq V_{IN} \leq V_{MAX}, I_{OUT}=1mA - 200mA$	22.80		25.20	V (Note 2)
Load Regulation	ΔV_{OUT}	$T_J=25^{\circ}C, I_{OUT}=1mA \sim 100mA$		40	200	mV
		$T_J=25^{\circ}C, I_{OUT}=1mA \sim 40mA$		20	100	mV
Line Regulation	ΔV_{OUT}	$27V \leq V_{IN} \leq 35V, T_J=25^{\circ}C$		60	300	mV
		$28V \leq V_{IN} \leq 35V, T_J=25^{\circ}C$		50	250	mV
Quiescent Current	I_Q			3.0	7.5	mA
Quiescent Current Change	ΔI_Q	$27V \leq V_{IN} \leq 35V$			1.5	mA
		$1mA \leq V_{IN} \leq 40mA$			0.1	mA
Output Noise Voltage	e_N	$10Hz \leq f \leq 100kHz$		200		μV
Temperature Coefficient of V_{OUT}	$\Delta V_O/\Delta T$	$I_{OUT}=5mA$		-2.0		$mV/^{\circ}C$
Ripple Rejection	RR	$27V \leq V_{IN} \leq 35V, f=120Hz, T_J=25^{\circ}C$		45		dB
Dropout Voltage	V_D	$T_J=25^{\circ}C$		1.7		V

Note: 1. The Maximum steady state usable output current are dependent on input voltage, heat sinking, lead length of the package and copper pattern of PCB. The data above represent pulse test conditions with junction temperatures specified at the initiation of test.

2. Power dissipation < 0.5W

APPLICATION CIRCUIT

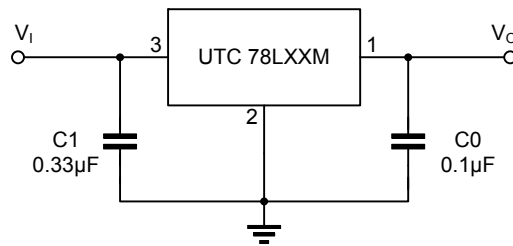

Notes 1: To specify an output voltage, substitute voltage value for "XXM".

2: Bypass capacitors are recommended for optimum stability and transient response and should be located as close as possible to the regulators.

TEST CIRCUIT

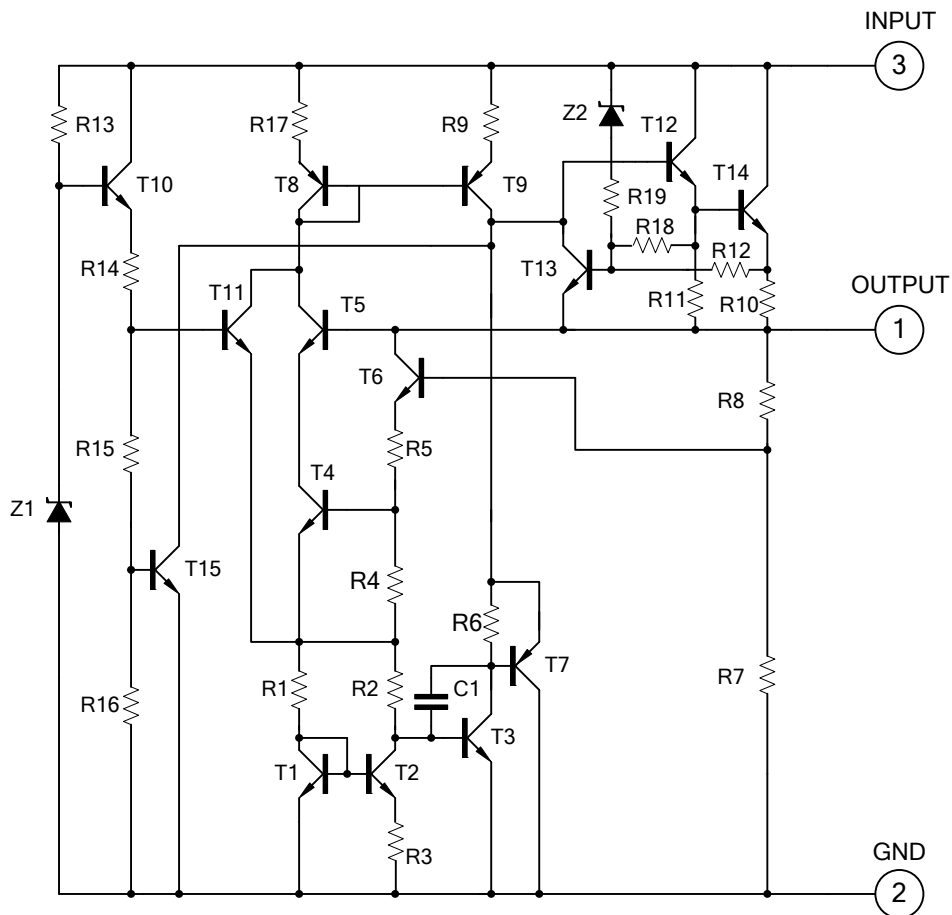

■ TYPICAL CHARACTERISTICS

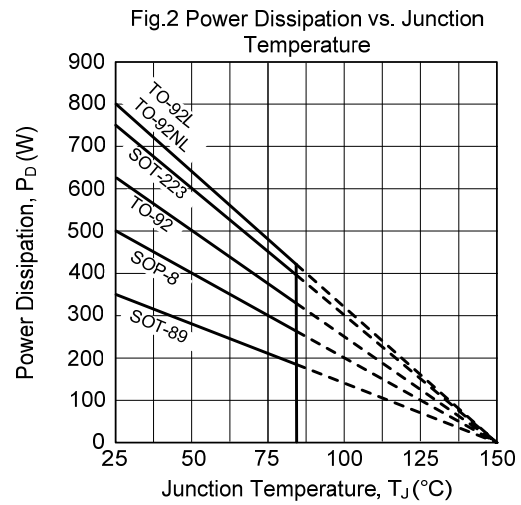
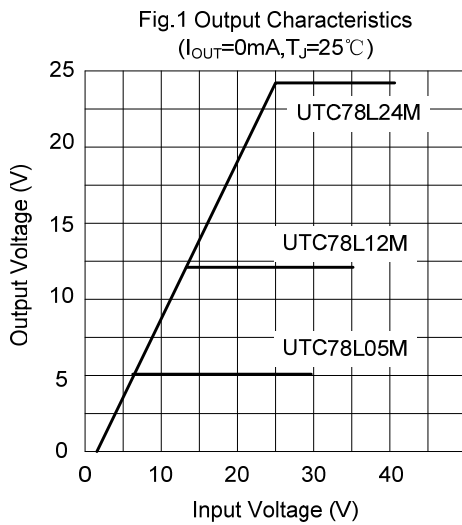

UTC assumes no responsibility for equipment failures that result from using products at values that exceed, even momentarily, rated values (such as maximum ratings, operating condition ranges, or other parameters) listed in products specifications of any and all UTC products described or contained herein. UTC products are not designed for use in life support appliances, devices or systems where malfunction of these products can be reasonably expected to result in personal injury. Reproduction in whole or in part is prohibited without the prior written consent of the copyright owner. UTC reserves the right to make changes to information published in this document, including without limitation specifications and product descriptions, at any time and without notice. This document supersedes and replaces all information supplied prior to the publication hereof.

X-ON Electronics

Largest Supplier of Electrical and Electronic Components

Click to view similar products for [Linear Voltage Regulators](#) category:

Click to view products by [Unisonic](#) manufacturer:

Other Similar products are found below :

[LV5684PVD-XH](#) [MCDTSA6-2R](#) [L7815ACV-DG](#) [LV56801P-E](#) [UA7805CKC](#) [714954EB](#) [ZMR500QFTA](#) [BA033LBSG2-TR](#)
[NCV78M05ABDTRKG](#) [LV5680P-E](#) [L79M05T-E](#) [L78LR05D-MA-E](#) [NCV317MBTG](#) [NTE7227](#) [MP2018GZD-33-P](#) [MP2018GZD-5-P](#)
[LV5680NPVC-XH](#) [ZTS6538SE](#) [UA78L09CLP](#) [UA78L09CLPR](#) [CAT6221-PPTD-GT3](#) [MC78M09CDTRK](#) [NCV51190MNTAG](#)
[BL1118CS8TR1833](#) [BL8077CKETR33](#) [BL9153-33CC3TR](#) [BL9161G-28BADRN](#) [BRCO7530MMC](#) [CJ7815B-TFN-ARG](#) [LM317C](#)
[GM7333K](#) [GM7350K](#) [XC6206P332MR](#) [HT7533](#) [LM7912S/TR](#) [LT1764S/TR](#) [LM7805T](#) [LM338T](#) [LM1117IMP-3.3/TR](#) [HT1117AM-3.3](#)
[HT7550S](#) [AMS1117-3.3](#) [HT7150S](#) [78L12](#) [HT7550](#) [HT7533-1](#) [HXY6206I-2.5](#) [HT7133](#) [HT7533S](#) [662K](#)