



## 78TXXA

## LINEAR INTEGRATED CIRCUIT

### 3-TERMINAL 1A POSITIVE VOLTAGE REGULATOR

#### DESCRIPTION

The UTC **78TXXA** family is monolithic fixed voltage regulator integrated circuit. They are suitable for applications that required supply current up to 1 A.

#### FEATURES

- \* Peak Output Current Up To 1 A
- \* Fixed Output Voltage Of 5V, 6V, 7V, 8V, 9V, 10V, 12V, 15V and 18V Available
- \* Thermal Overload Shutdown Protection
- \* Short Circuit Current Limiting
- \* Output Transistor SOA Protection

#### ORDERING INFORMATION

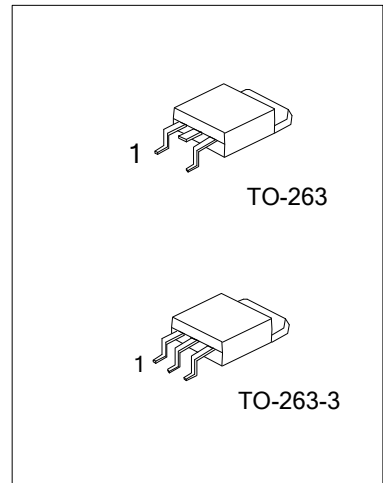

Ordering Number		Package	Pin Assignment			Packing
Lead Free	Halogen Free		1	2	3	
78TXXAL-TQ2-R	78TXXAG-TQ2-R	TO-263	I	G	O	Tape Reel
78TXXAL-TQ2-T	78TXXAG-TQ2-T	TO-263	I	G	O	Tube
78TXXAL-TQ3-R	78TXXAG-TQ3-R	TO-263-3	I	G	O	Tape Reel
78TXXAL-TQ3-T	78TXXAG-TQ3-T	TO-263-3	I	G	O	Tube

Note: Pin Code: I: Input G: GND O: Output

<p>78TXXAL-TQ2-R</p> <p>(1)Packing Type (2)Package Type (3)Lead Free (4)Output Voltage Code</p>	<p>(1) R: Tape Reel, T: Tube (2) TO-263: TQ2, TO-263-3: TQ3 (3) L: Lead Free, G: Halogen Free (4) XX: refer to Marking Information</p>
---	--

■ MARKING INFORMATION

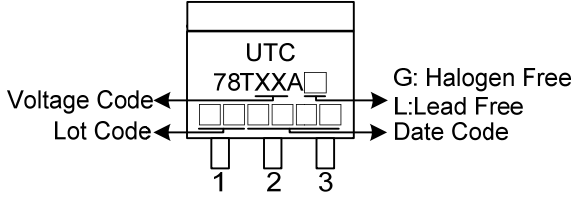
PACKAGE	VOLTAGE CODE	MARKING
TO-263 TO-263-3	05 :5.0V 06 :6.0V 07 :7.0V 08 :8.0V 09 :9.0V 10 :10V 12 :12V 15 :15V 18 :18V	 <p style="text-align: center;">                         UTC                          78TXXA □                          □ □ □ □                          Voltage Code ←      → G: Halogen Free                          Lot Code ←                      → L: Lead Free                          Date Code                     </p> <p style="text-align: center;">1    2    3</p>

### ■ TEST CIRCUIT

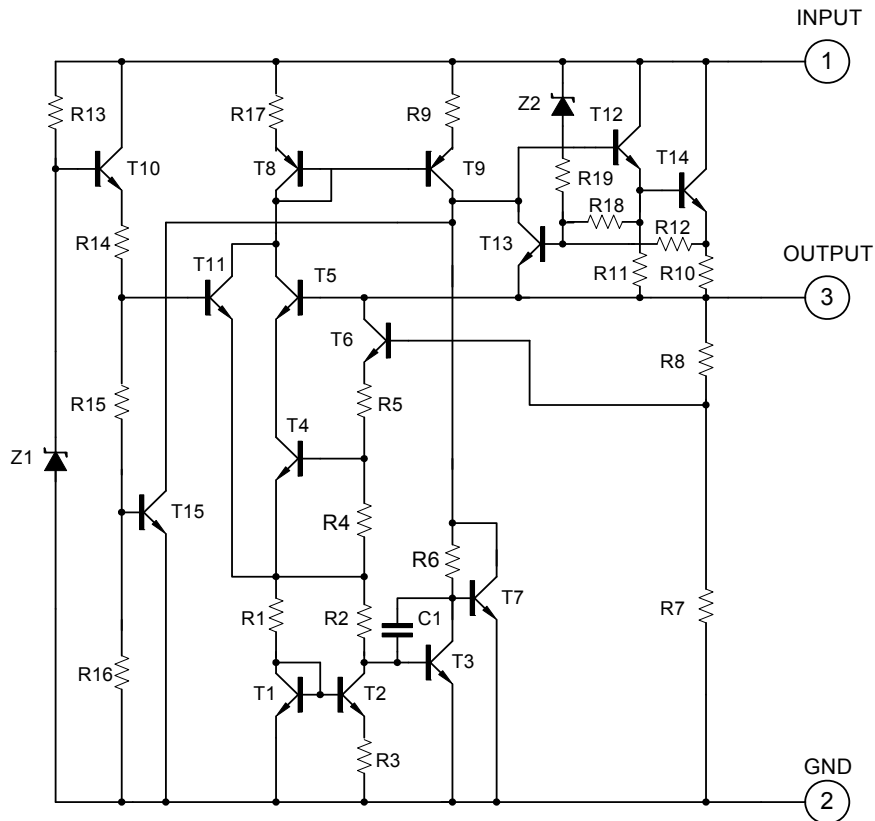

### ■ APPLICATION CIRCUIT

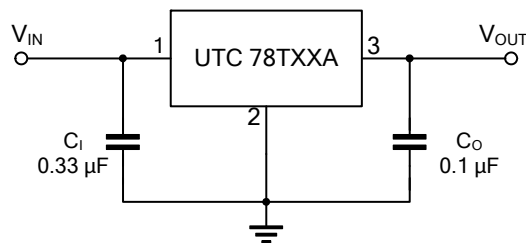

Note 1: To specify an output voltage, substitute voltage value for "XX".

2: Bypass capacitors are recommended for optimum stability and transient response and should be located as close as possible to the regulators.

■ ABSOLUTE MAXIMUM RATINGS (Operating temperature range applies unless otherwise specified)

PARAMETER	SYMBOL	RATING	UNIT
Input Voltage	$V_{IN}$	35	V
Output Current	$I_{OUT}$	1	A
Power Dissipation	$P_D$	Internally Limited	W
Junction Temperature	$T_J$	+125	°C
Operating Junction Temperature	$T_{OPR}$	-40~ +85	°C
Storage Temperature	$T_{STG}$	-40~ +150	°C

Note: Absolute maximum ratings are those values beyond which the device could be permanently damaged.

Absolute maximum ratings are stress ratings only and functional device operation is not implied.

■ ELECTRICAL CHARACTERISTICS

( $T_J = 0^\circ\text{C} \sim 125^\circ\text{C}$ ,  $C_I = 0.33\mu\text{F}$ ,  $C_O = 0.1\mu\text{F}$ , unless otherwise specified) (Note 1)

**FOR 78T05A** ( $V_{IN} = 10\text{V}$ ,  $I_{OUT} = 0.5\text{A}$ )

PARAMETER	SYMBOL	TEST CONDITIONS	MIN	TYP	MAX	UNIT
Output Voltage	$V_{OUT}$	$T_J = 25^\circ\text{C}$ , $I_{OUT} = 5\text{mA} \sim 1.0\text{A}$	4.80	5.0	5.20	V
		$V_{IN} = 7.5\text{V} \sim 20\text{V}$ , $I_{OUT} = 5\text{mA} \sim 1.0\text{A}$ , $P_D \leq 15\text{W}$	4.75		5.25	V
Load Regulation	$\Delta V_{OUT}$	$T_J = 25^\circ\text{C}$ , $I_{OUT} = 5\text{mA} \sim 1.0\text{A}$			50	mV
		$T_J = 25^\circ\text{C}$ , $I_{OUT} = 0.25\text{A} \sim 0.75\text{A}$			25	mV
Line regulation	$\Delta V_{OUT}$	$V_{IN} = 7\text{V} \sim 25\text{V}$ , $T_J = 25^\circ\text{C}$			50	mV
		$V_{IN} = 7.5\text{V} \sim 20\text{V}$ , $T_J = 25^\circ\text{C}$ , $I_{OUT} = 1.0\text{A}$			50	mV
Quiescent Current	$I_Q$	$T_J = 25^\circ\text{C}$ , $I_{OUT} \leq 1.0\text{A}$			8.0	mA
Quiescent Current Change	$\Delta I_Q$	$V_{IN} = 7.5\text{V} \sim 20\text{V}$			1.0	mA
		$I_{OUT} = 5\text{mA} \sim 1.0\text{A}$			0.5	mA
Output Noise Voltage	eN	$10\text{Hz} \leq f \leq 100\text{kHz}$		40		$\mu\text{V}$
Temperature coefficient of $V_o$	$\Delta V_o / \Delta T$	$I_{OUT} = 5\text{mA}$		-0.6		$\text{mV}/^\circ\text{C}$
Ripple Rejection	RR	$V_{IN} = 8\text{V} \sim 18\text{V}$ , $f = 120\text{Hz}$ , $T_J = 25^\circ\text{C}$	62	80		dB
Peak Output Current	$I_{PEAK}$	$T_J = 25^\circ\text{C}$		1.8		A
Short-Circuit Current	$I_{SC}$	$V_{IN} = 35\text{V}$ , $T_J = 25^\circ\text{C}$		250		mA
Dropout Voltage	$V_D$	$T_J = 25^\circ\text{C}$		2.0		V

**FOR 78T06A** ( $V_{IN} = 11\text{V}$ ,  $I_{OUT} = 0.5\text{A}$ )

PARAMETER	SYMBOL	TEST CONDITIONS	MIN	TYP	MAX	UNIT
Output Voltage	$V_{OUT}$	$T_J = 25^\circ\text{C}$ , $I_{OUT} = 5\text{mA} \sim 1.0\text{A}$	5.76	6.0	6.24	V
		$V_{IN} = 8.5\text{V} \sim 21\text{V}$ , $I_{OUT} = 5\text{mA} \sim 1.0\text{A}$ , $P_D \leq 15\text{W}$	5.70		6.30	V
Load Regulation	$\Delta V_{OUT}$	$T_J = 25^\circ\text{C}$ , $I_{OUT} = 5\text{mA} \sim 1.0\text{A}$			60	mV
		$T_J = 25^\circ\text{C}$ , $I_{OUT} = 0.25\text{A} \sim 0.75\text{A}$			30	mV
Line regulation	$\Delta V_{OUT}$	$V_{IN} = 8\text{V} \sim 25\text{V}$ , $T_J = 25^\circ\text{C}$			60	mV
		$V_{IN} = 8.5\text{V} \sim 21\text{V}$ , $T_J = 25^\circ\text{C}$ , $I_{OUT} = 1.0\text{A}$			60	mV
Quiescent Current	$I_Q$	$T_J = 25^\circ\text{C}$ , $I_{OUT} \leq 1.0\text{A}$			8.0	mA
Quiescent Current Change	$\Delta I_Q$	$V_{IN} = 8.5\text{V} \sim 21\text{V}$			1.0	mA
		$I_{OUT} = 5\text{mA} \sim 1.0\text{A}$			0.5	mA
Output Noise Voltage	eN	$10\text{Hz} \leq f \leq 100\text{kHz}$		45		$\mu\text{V}$
Temperature coefficient of $V_o$	$\Delta V_o / \Delta T$	$I_{OUT} = 5\text{mA}$		-0.7		$\text{mV}/^\circ\text{C}$
Ripple Rejection	RR	$V_{IN} = 9\text{V} \sim 19\text{V}$ , $f = 120\text{Hz}$ , $T_J = 25^\circ\text{C}$	59	75		dB
Peak Output Current	$I_{PEAK}$	$T_J = 25^\circ\text{C}$		1.8		A
Short-Circuit Current	$I_{SC}$	$V_{IN} = 35\text{V}$ , $T_J = 25^\circ\text{C}$		250		mA
Dropout Voltage	$V_D$	$T_J = 25^\circ\text{C}$		2.0		V

■ ELECTRICAL CHARACTERISTICS(Cont.)

FOR 78T07A ( $V_{IN}=13V$ ,  $I_{OUT}=0.5A$ )

PARAMETER	SYMBOL	TEST CONDITIONS	MIN	TYP	MAX	UNIT
Output Voltage	$V_{OUT}$	$T_J=25^{\circ}C$ , $I_{OUT}=5mA-1.0A$	6.72	7.0	7.28	V
		$V_{IN}=9.5V\sim 22V$ , $I_{OUT}=5mA-1.0A$ , $P_D \leq 15W$	6.65		7.35	V
Load Regulation	$\Delta V_{OUT}$	$T_J=25^{\circ}C$ , $I_{OUT}=5mA-1.0A$			70	mV
		$T_J=25^{\circ}C$ , $I_{OUT}=0.25A-0.75A$			35	mV
Line regulation	$\Delta V_{OUT}$	$V_{IN}=9V\sim 25V$ , $T_J=25^{\circ}C$			70	mV
		$V_{IN}=9.5V\sim 22V$ , $T_J=25^{\circ}C$ , $I_{OUT}=1.0A$			70	mV
Quiescent Current	$I_Q$	$T_J=25^{\circ}C$ , $I_{OUT} \leq 1.0A$			8.0	mA
Quiescent Current Change	$\Delta I_Q$	$V_{IN}=9.5V\sim 22V$			1.0	mA
		$I_{OUT}=5mA-1.0A$			0.5	mA
Output Noise Voltage	eN	$10Hz \leq f \leq 100kHz$		50		$\mu V$
Temperature coefficient of $V_o$	$\Delta V_o/\Delta T$	$I_{OUT}=5mA$		-0.8		mV/ $^{\circ}C$
Ripple Rejection	RR	$V_{IN}=10V-20V$ , $f=120Hz$ , $T_J=25^{\circ}C$	59	75		dB
Peak Output Current	$I_{PEAK}$	$T_J=25^{\circ}C$		1.7		A
Short-Circuit Current	$I_{SC}$	$V_{IN}=35V$ , $T_J=25^{\circ}C$		250		mA
Dropout Voltage	$V_D$	$T_J=25^{\circ}C$		2.0		V

FOR 78T08A ( $V_{IN}=14V$ ,  $I_{OUT}=0.5A$ )

PARAMETER	SYMBOL	TEST CONDITIONS	MIN	TYP	MAX	UNIT
Output Voltage	$V_{OUT}$	$T_J=25^{\circ}C$ , $I_{OUT}=5mA-1.0A$	7.68	8.0	8.32	V
		$V_{IN}=10.5V\sim 23V$ , $I_{OUT}=5mA-1.0A$ , $P_D \leq 15W$	7.60		8.40	V
Load Regulation	$\Delta V_{OUT}$	$T_J=25^{\circ}C$ , $I_{OUT}=5mA-1.0A$			80	mV
		$T_J=25^{\circ}C$ , $I_{OUT}=0.25A-0.75A$			40	mV
Line regulation	$\Delta V_{OUT}$	$V_{IN}=10.5V\sim 25V$ , $T_J=25^{\circ}C$			80	mV
		$V_{IN}=10.5V\sim 23V$ , $T_J=25^{\circ}C$ , $I_{OUT}=1.0A$			80	mV
Quiescent Current	$I_Q$	$T_J=25^{\circ}C$ , $I_{OUT} \leq 1.0A$			8.0	mA
Quiescent Current Change	$\Delta I_Q$	$V_{IN}=10.5V\sim 23V$			1.0	mA
		$I_{OUT}=5mA-1.0A$			0.5	mA
Output Noise Voltage	eN	$10Hz \leq f \leq 100kHz$		58		$\mu V$
Temperature coefficient of $V_o$	$\Delta V_o/\Delta T$	$I_{OUT}=5mA$		-0.9		mV/ $^{\circ}C$
Ripple Rejection	RR	$V_{IN}=11.5V\sim 21.5V$ , $f=120Hz$ , $T_J=25^{\circ}C$	56	72		dB
Peak Output Current	$I_{PEAK}$	$T_J=25^{\circ}C$		1.8		A
Short-Circuit Current	$I_{SC}$	$V_{IN}=35V$ , $T_J=25^{\circ}C$		250		mA
Dropout Voltage	$V_D$	$T_J=25^{\circ}C$		2.0		V

FOR 78T09A ( $V_{IN}=15V$ ,  $I_{OUT}=0.5A$ )

PARAMETER	SYMBOL	TEST CONDITIONS	MIN	TYP	MAX	UNIT
Output Voltage	$V_{OUT}$	$T_J=25^{\circ}C$ , $I_{OUT}=5mA-1.0A$	8.64	9.0	9.36	V
		$V_{IN}=11.5V\sim 24V$ , $I_{OUT}=5mA-1.0A$ , $P_D \leq 15W$	8.55		9.45	V
Load Regulation	$\Delta V_{OUT}$	$T_J=25^{\circ}C$ , $I_{OUT}=5mA-1.0A$			90	mV
		$T_J=25^{\circ}C$ , $I_{OUT}=0.25A-0.75A$			45	mV
Line regulation	$\Delta V_{OUT}$	$V_{IN}=11.5V\sim 25V$ , $T_J=25^{\circ}C$			90	mV
		$V_{IN}=11.5V\sim 24V$ , $T_J=25^{\circ}C$ , $I_{OUT}=1.0A$			90	mV
Quiescent Current	$I_Q$	$T_J=25^{\circ}C$ , $I_{OUT} \leq 1.0A$			8.0	mA
Quiescent Current Change	$\Delta I_Q$	$V_{IN}=11.5V\sim 24V$			1.0	mA
		$I_{OUT}=5mA-1.0A$			0.5	mA
Output Noise Voltage	eN	$10Hz \leq f \leq 100kHz$		58		$\mu V$
Temperature coefficient of $V_o$	$\Delta V_o/\Delta T$	$I_{OUT}=5mA$		-1.1		mV/ $^{\circ}C$
Ripple Rejection	RR	$V_{IN}=12.5V\sim 22.5V$ , $f=120Hz$ , $T_J=25^{\circ}C$	56	72		dB
Peak Output Current	$I_{PEAK}$	$T_J=25^{\circ}C$		1.8		A
Short-Circuit Current	$I_{SC}$	$V_{IN}=35V$ , $T_J=25^{\circ}C$		250		mA
Dropout Voltage	$V_D$	$T_J=25^{\circ}C$		2.0		V

■ ELECTRICAL CHARACTERISTICS(Cont.)

FOR 78T10A ( $V_{IN}=16V$ ,  $I_{OUT}=0.5A$ )

PARAMETER	SYMBOL	TEST CONDITIONS	MIN	TYP	MAX	UNIT
Output Voltage	$V_{OUT}$	$T_J=25^{\circ}C$ , $I_{OUT}=5mA-1.0A$	9.60	10.0	10.40	V
		$V_{IN}=12.5V\sim 25V$ , $I_{OUT}=5mA-1.0A$ , $P_D \leq 15W$	9.50		10.50	V
Load Regulation	$\Delta V_{OUT}$	$T_J=25^{\circ}C$ , $I_{OUT}=5mA-1.0A$			100	mV
		$T_J=25^{\circ}C$ , $I_{OUT}=0.25A-0.75A$			50	mV
Line regulation	$\Delta V_{OUT}$	$V_{IN}=13V\sim 25V$ , $T_J=25^{\circ}C$			100	mV
		$V_{IN}=13V\sim 25V$ , $T_J=25^{\circ}C$ , $I_{OUT}=1.0A$			100	mV
Quiescent Current	$I_Q$	$T_J=25^{\circ}C$ , $I_{OUT} \leq 1.0A$			8.0	mA
Quiescent Current Change	$\Delta I_Q$	$V_{IN}=12.6V\sim 25V$			1.0	mA
		$I_{OUT}=5mA-1.0A$			0.5	mA
Output Noise Voltage	eN	$10Hz \leq f \leq 100kHz$		58		$\mu V$
Temperature coefficient of $V_o$	$\Delta V_o/\Delta T$	$I_{OUT}=5mA$		-1.1		mV/ $^{\circ}C$
Ripple Rejection	RR	$V_{IN}=13V-23V$ , $f=120Hz$ , $T_J=25^{\circ}C$	56	72		dB
Peak Output Current	$I_{PEAK}$	$T_J=25^{\circ}C$		1.8		A
Short-Circuit Current	$I_{SC}$	$V_{IN}=35V$ , $T_J=25^{\circ}C$		250		mA
Dropout Voltage	$V_D$	$T_J=25^{\circ}C$		2.0		V

FOR 78T12A ( $V_{IN}=19V$ ,  $I_{OUT}=0.5A$ )

PARAMETER	SYMBOL	TEST CONDITIONS	MIN	TYP	MAX	UNIT
Output Voltage	$V_{OUT}$	$T_J=25^{\circ}C$ , $I_{OUT}=5mA-1.0A$	11.52	12.0	12.48	V
		$V_{IN}=14.5V\sim 27V$ , $I_{OUT}=5mA-1.0A$ , $P_D \leq 15W$	11.40		12.60	V
Load Regulation	$\Delta V_{OUT}$	$T_J=25^{\circ}C$ , $I_{OUT}=5mA-1.0A$			120	mV
		$T_J=25^{\circ}C$ , $I_{OUT}=0.25A-0.75A$			60	mV
Line regulation	$\Delta V_{OUT}$	$V_{IN}=14.5V\sim 30V$ , $T_J=25^{\circ}C$			120	mV
		$V_{IN}=14.6V\sim 27V$ , $T_J=25^{\circ}C$ , $I_{OUT}=1.0A$			120	mV
Quiescent Current	$I_Q$	$T_J=25^{\circ}C$ , $I_{OUT} \leq 1.0A$			8.0	mA
Quiescent Current Change	$\Delta I_Q$	$V_{IN}=14.5V\sim 30V$			1.0	mA
		$I_{OUT}=5mA-1.0A$			0.5	mA
Output Noise Voltage	eN	$10Hz \leq f \leq 100kHz$		75		$\mu V$
Temperature coefficient of $V_o$	$\Delta V_o/\Delta T$	$I_{OUT}=5mA$		-1.5		mV/ $^{\circ}C$
Ripple Rejection	RR	$V_{IN}=15V-25V$ , $f=120Hz$ , $T_J=25^{\circ}C$	55	72		dB
Peak Output Current	$I_{PEAK}$	$T_J=25^{\circ}C$		1.8		A
Short-Circuit Current	$I_{SC}$	$V_{IN}=35V$ , $T_J=25^{\circ}C$		250		mA
Dropout Voltage	$V_D$	$T_J=25^{\circ}C$		2.0		V

FOR 78T15A ( $V_{IN}=23V$ ,  $I_{OUT}=0.5A$ )

PARAMETER	SYMBOL	TEST CONDITIONS	MIN	TYP	MAX	UNIT
Output Voltage	$V_{OUT}$	$T_J=25^{\circ}C$ , $I_{OUT}=5mA-1.0A$	14.40	15.0	15.60	V
		$V_{IN}=17.5V\sim 30V$ , $I_{OUT}=5mA-1.0A$ , $P_D \leq 15W$	14.25		15.75	V
Load Regulation	$\Delta V_{OUT}$	$T_J=25^{\circ}C$ , $I_{OUT}=5mA-1.0A$			150	mV
		$T_J=25^{\circ}C$ , $I_{OUT}=0.25A-0.75A$			75	mV
Line regulation	$\Delta V_{OUT}$	$V_{IN}=18.5V\sim 30V$ , $T_J=25^{\circ}C$			150	mV
		$V_{IN}=17.7V\sim 30V$ , $T_J=25^{\circ}C$ , $I_{OUT}=1.0A$			150	mV
Quiescent Current	$I_Q$	$T_J=25^{\circ}C$ , $I_{OUT} \leq 1.0A$			8.0	mA
Quiescent Current Change	$\Delta I_Q$	$V_{IN}=17.5V\sim 30V$			1.0	mA
		$I_{OUT}=5mA-1.0A$			0.5	mA
Output Noise Voltage	eN	$10Hz \leq f \leq 100kHz$		90		$\mu V$
Temperature coefficient of $V_o$	$\Delta V_o/\Delta T$	$I_{OUT}=5mA$		-1.8		mV/ $^{\circ}C$
Ripple Rejection	RR	$V_{IN}=18.5V\sim 28.5V$ , $f=120Hz$ , $T_J=25^{\circ}C$	54	70		dB
Peak Output Current	$I_{PEAK}$	$T_J=25^{\circ}C$		1.8		A
Short-Circuit Current	$I_{SC}$	$V_{IN}=35V$ , $T_J=25^{\circ}C$		250		mA
Dropout Voltage	$V_D$	$T_J=25^{\circ}C$		2.0		V

■ ELECTRICAL CHARACTERISTICS(Cont.)

FOR 78T18A ( $V_{IN}=27V$ ,  $I_{OUT}=0.5A$ )

PARAMETER	SYMBOL	TEST CONDITIONS	MIN	TYP	MAX	UNIT
Output Voltage	$V_{OUT}$	$T_J=25^{\circ}C$ , $I_{OUT}=5mA-1.0A$	17.28	18.0	18.72	V
		$V_{IN}=21V\sim 33V$ , $I_{OUT}=5mA-1.0A$ , $P_D \leq 15W$	17.10		18.90	V
Load Regulation	$\Delta V_{OUT}$	$T_J=25^{\circ}C$ , $I_{OUT}=5mA-1.0A$			180	mV
		$T_J=25^{\circ}C$ , $I_{OUT}=0.25A-0.75A$			90	mV
Line regulation	$\Delta V_{OUT}$	$V_{IN}=21V\sim 33V$ , $T_J=25^{\circ}C$			180	mV
		$V_{IN}=21V\sim 33V$ , $T_J=25^{\circ}C$ , $I_{OUT}=1.0A$			180	mV
Quiescent Current	$I_Q$	$T_J=25^{\circ}C$ , $I_{OUT} \leq 1.0A$			8.0	mA
Quiescent Current Change	$\Delta I_Q$	$V_{IN}=21.5V\sim 33V$			1.0	mA
		$I_{OUT}=5mA-1.0A$			0.5	mA
Output Noise Voltage	eN	$10Hz \leq f \leq 100kHz$		110		$\mu V$
Temperature coefficient of $V_o$	$\Delta V_o/\Delta T$	$I_{OUT}=5mA$		-2.2		$mV/^{\circ}C$
Ripple Rejection	RR	$V_{IN}=22V-32V$ , $f=120Hz$ , $T_J=25^{\circ}C$	53	69		dB
Peak Output Current	$I_{PEAK}$	$T_J=25^{\circ}C$		1.8		A
Short-Circuit Current	$I_{SC}$	$V_{IN}=35V$ , $T_J=25^{\circ}C$		250		mA
Dropout Voltage	$V_D$	$T_J=25^{\circ}C$		2.0		V

Note 1: The Maximum steady state usable output current are dependent on input voltage, heat sinking, lead length of the package and copper pattern of PCB. The data above represents pulse test conditions with junction temperatures specified at the initiation of test.

2: Power dissipation<0.5W

### TYPICAL CHARACTERISTICS

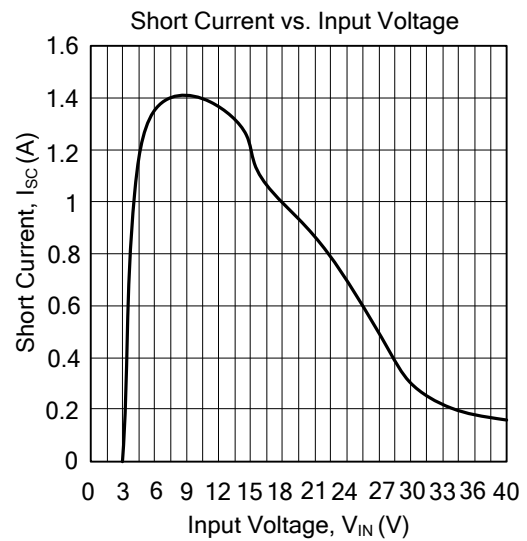
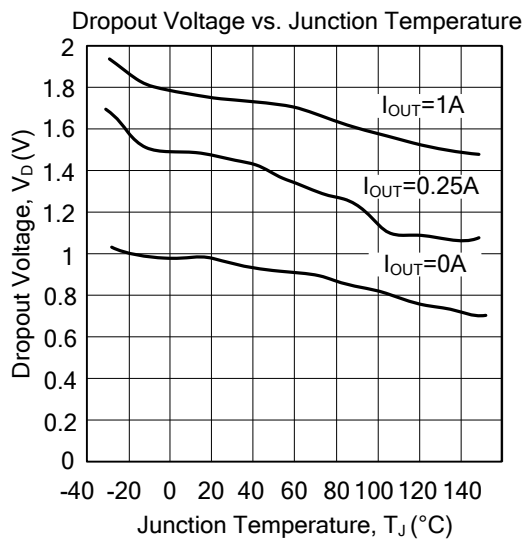
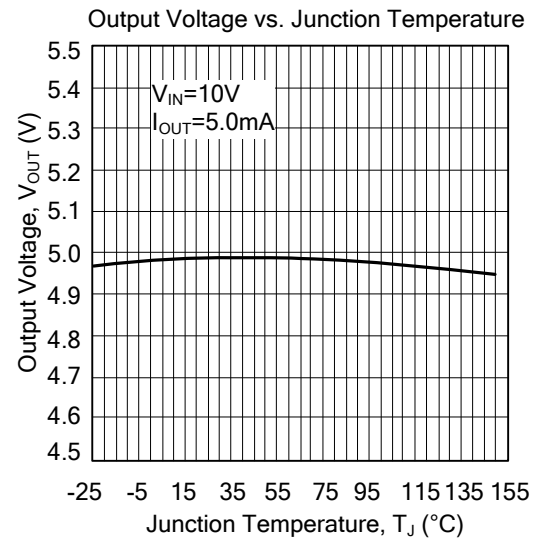
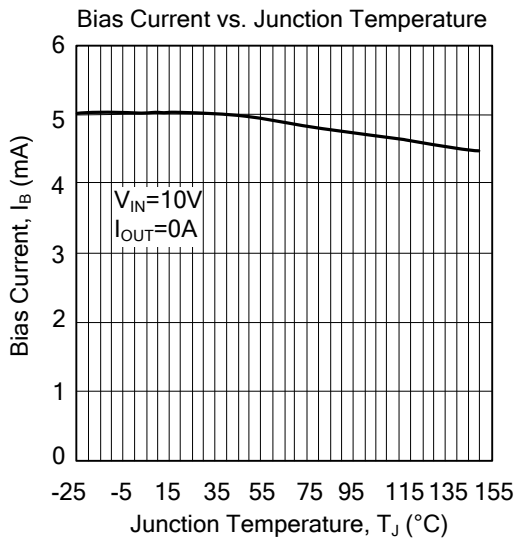
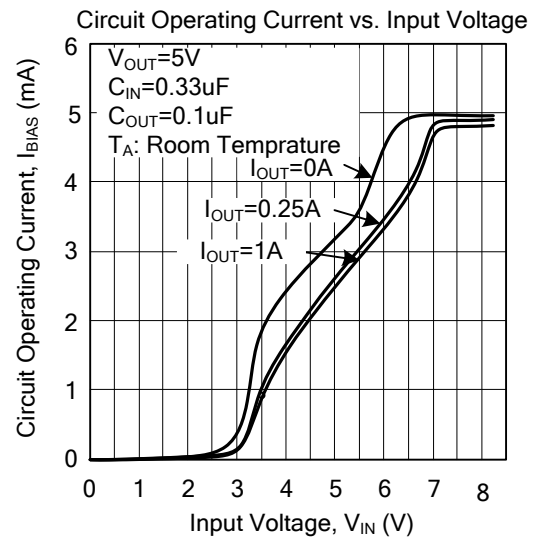
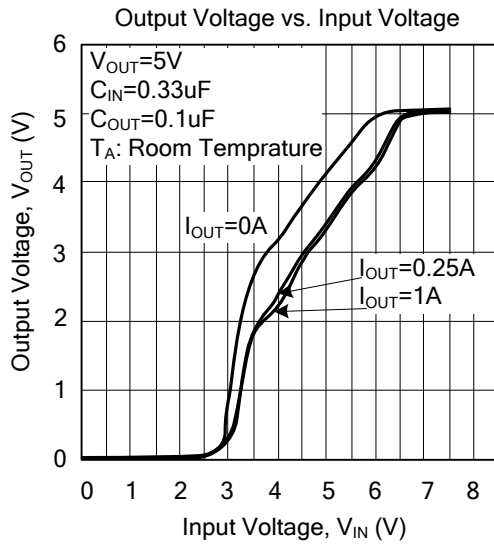



### ■ TYPICAL CHARACTERISTICS(Cont.)

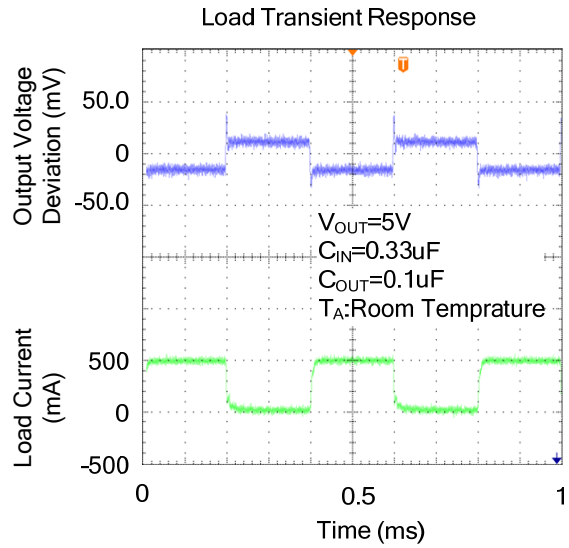
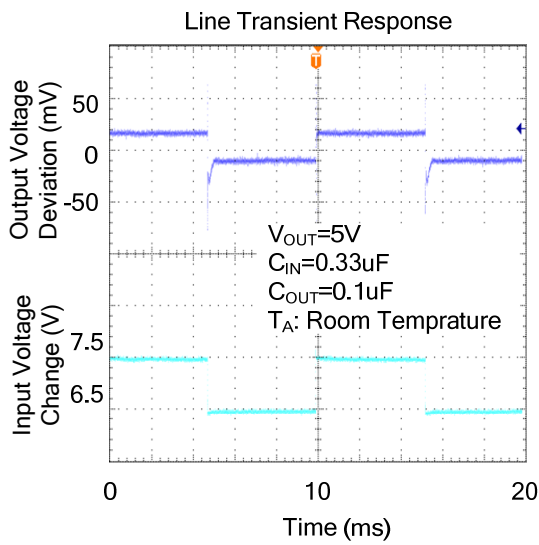

UTC assumes no responsibility for equipment failures that result from using products at values that exceed, even momentarily, rated values (such as maximum ratings, operating condition ranges, or other parameters) listed in products specifications of any and all UTC products described or contained herein. UTC products are not designed for use in life support appliances, devices or systems where malfunction of these products can be reasonably expected to result in personal injury. Reproduction in whole or in part is prohibited without the prior written consent of the copyright owner. The information presented in this document does not form part of any quotation or contract, is believed to be accurate and reliable and may be changed without notice.

## X-ON Electronics

Largest Supplier of Electrical and Electronic Components

*Click to view similar products for [Linear Voltage Regulators](#) category:*

*Click to view products by [Unisonic](#) manufacturer:*

Other Similar products are found below :

[LV56831P-E](#) [LV5684PVD-XH](#) [MCDTSA6-2R](#) [L7815ACV-DG](#) [PQ3DZ53U](#) [LV56801P-E](#) [L78L05CZ/1SX](#) [L78LR05DL-MA-E](#) [636416C](#)  
[714954EB](#) [ZMR500QFTA](#) [LV5680P-E](#) [L78M15CV-DG](#) [L79M05T-E](#) [MIC5283-5.0YML-T5](#) [TLS202A1MBVHTSA1](#) [L78LR05D-MA-E](#)  
[NCV317MBTG](#) [NTE7227](#) [MP2018GZD-33-P](#) [MP2018GZD-5-P](#) [LV5680NPVC-XH](#) [LT1054CN8](#) [MP2018GZD-5-Z](#) [MP2018GZD-33-Z](#)  
[MD57E21WB6](#) [MD57E28WB6](#) [WL2810D33-4/TR](#) [WL2815D33-4/TR](#) [ZTS6538SE](#) [MC78L06BP-AP](#) [TA48LS05F\(TE85L,F\)](#)  
[TA78L12F\(TE12L,F\)](#) [TC47BR5003ECT](#) [TCR2LN12,LF\(S](#) [TCR2LN28,LF\(S](#) [TCR2LN30,LF\(S](#) [TCR3DF295,LM\(CT](#) [TCR3DF40,LM\(CT](#)  
[TPS549B22RVFT](#) [L78M12ABDT](#) [LM7812SX/NOPB](#) [LR645N3-G-P003](#) [LR645N3-G-P013](#) [ZXTR2005P5-13](#) [SCD7812BTG](#)  
[TCR3DF335,LM\(CT](#) [ZXTR2012K-13](#) [TLE42994E V33](#) [ZXTR2008K-13](#)