



79DXX

LINEAR INTEGRATED CIRCUIT

3 TERMINAL 0.5A NEGATIVE VOLTAGE REGULATOR

DESCRIPTION

The UTC **79DXX** series of three-terminal negative regulators are available in TO-251 and TO-252 packages and with several fixed output voltage, making them useful in a wide range of application. Each type employs internal current limiting, thermal shut-down and safe area protection, making it essentially indestructible.

FEATURES

- * Output current up to 0.5A
- * -5V, -6V, -8V, -12V, -15V, -18V, -24V output voltage available
- * Thermal overload protection
- * Short circuit protection

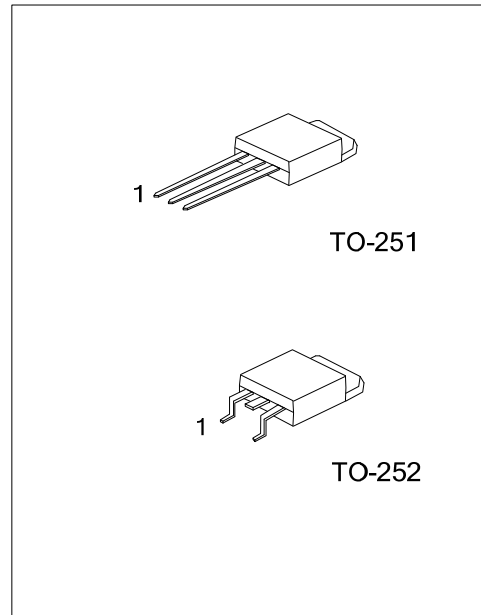

ORDERING INFORMATION

Ordering Number		Package	Pin Assignment			Packing
Lead Free	Halogen Free		1	2	3	
79DXXL-TM3-T	79DXXG-TM3-T	TO-251	G	I	O	Tube
79DXXL-TN3-T	79DXXG-TN3-T	TO-252	G	I	O	Tube
79DXXL-TN3-R	79DXXG-TN3-R	TO-252	G	I	O	Tape Reel

Note: 1. xx: output voltage, refer to Marking Information
 2. Pin Code: I: Input G: GND O: Output

<p>79DXXL-TM3-T</p> <p>(1)Packing Type (2)Package Type (3)Green Package (4)Output Voltage Code</p>	<p>(1) T: Tube, R: Tape Reel (2) TM3: TO-251, TN3: TO-252 (3) L: Lead Free, G: Halogen Free and Lead Free (4) xx: refer to Marking Information</p>
---	---

MARKING INFORMATION

PACKAGE	VOLTAGE CODE	MARKING
TO-251 TO-252	05 : -5V	
	06 : -6V	
	08 : -8V	
	09 : -9V	
	12 : -12V	
	15 : -15V	
	18 : -18V	
24 : -24V		

BLOCK DIAGRAM

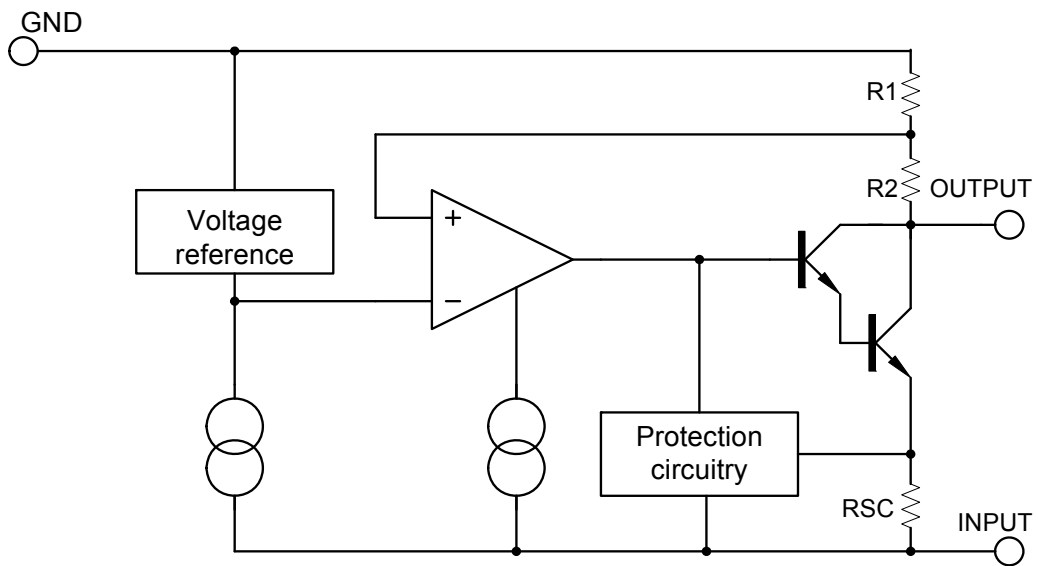

■ ABSOLUTE MAXIMUM RATINGS (T_A=25°C)

PARAMETER	SYMBOL	RATINGS	UNIT	
Input Voltage	V _{IN}	V _{OUT} = -5 ~ -18V	-35	V
		V _{OUT} = -20 ~ -24V	-40	V
Operating Temperature	T _{OPR}	-40 ~ +85	°C	
Storage Temperature	T _{STG}	-65 ~ +150	°C	

Note: Absolute maximum ratings are those values beyond which the device could be permanently damaged. Absolute maximum ratings are stress ratings only and functional device operation is not implied.

■ THERMAL DATA

PARAMETER	SYMBOL	RATINGS	UNIT
Thermal Resistance Junction-Air	θ _{JA}	65	°C/W
Thermal Resistance Junction-Cases	θ _{JC}	5	°C/W

■ ELECTRICAL CHARACTERISTICS (0<T_J<125°C, unless otherwise specified)

FOR 79D05 (V_{IN}=-10V, I_{OUT}=500mA, C_I=33μF, C_O=1μF)

PARAMETER	SYMBOL	TEST CONDITIONS	MIN	TYP	MAX	UNIT
Output Voltage	V _{OUT}	T _J =25°C	-4.80	-5.0	-5.20	V
		5.0mA<I _{OUT} <0.5A, P _{OUT} <15W V _{IN} =-7V ~ -20V	-4.75		-5.25	V
Line Regulation	ΔV _{OUT}	T _J =25°C, V _{IN} =-7V ~ -25V		10	100	mV
		T _J =25°C, V _{IN} =-8V ~ -12V				mV
Load Regulation	ΔV _{OUT}	T _J =25°C, I _{OUT} =5.0mA ~ 0.5A		10	100	mV
		T _J =25°C, I _{OUT} =5.0mA ~ 200mA		3	50	mV
Quiescent Current	I _Q	T _J =25°C		4.3	8	mA
Quiescent Current Change	ΔI _Q	I _{OUT} =5mA ~ 0.5A		0.05	0.5	mA
		V _{IN} =-7V ~ -25V		0.1	1.3	mA
Temperature Coefficient of V _{OUT}	ΔV _{OUT} /ΔT	I _{OUT} =5mA		-0.4		mV/°C
Output Noise Voltage	V _N	f=10Hz ~ 100kHz, T _a =25°C		100		μV
Ripple Rejection	RR	f=120Hz, V _{IN} =-8V ~ -18V	54	60		dB
Dropout Voltage	V _D	I _{OUT} =1.0A, T _J =25°C		2		V

FOR 79D06 (V_{IN}=-11V, I_{OUT}=500mA, C_I=2.2μF, C_O=1μF)

PARAMETER	SYMBOL	TEST CONDITIONS	MIN	TYP	MAX	UNIT
Output Voltage	V _{OUT}	T _J =25°C	-5.76	-6.0	-6.24	V
		5.0mA<I _{OUT} <0.5A, P _{OUT} <15W V _{IN} =-8V ~ -21V	-5.70		-6.30	V
Line Regulation	ΔV _{OUT}	T _J =25°C, V _{IN} =-8V ~ -25V		10	120	mV
		T _J =25°C, V _{IN} =-9V ~ -13V		5	60	mV
Load Regulation	ΔV _{OUT}	T _J =25°C, I _{OUT} =5.0mA ~ 0.5A		10	120	mV
		T _J =25°C, I _{OUT} =5.0mA ~ 200mA		3	60	mV
Quiescent Current	I _Q	T _J =25°C		4.3	8	mA
Quiescent Current Change	ΔI _Q	I _{OUT} =5mA ~ 0.5A			0.5	mA
		V _{IN} =-8V ~ -25V			1.3	mA
Temperature Coefficient of V _{OUT}	ΔV _{OUT} /ΔT	I _{OUT} =5mA		-0.5		mV/°C
Output Noise Voltage	e _N	F=10Hz ~ 100kHz, T _a =25°C		130		μV
Ripple Rejection	RR	F=120Hz, V _{IN} =-9V ~ -19V	54	60		dB
Dropout Voltage	V _D	I _{OUT} =0.5A, T _J =25°C		2		V

■ ELECTRICAL CHARACTERISTICS(Cont.)

FOR 79D08 ($V_{IN}=-14V$, $I_{OUT}=500mA$, $C_I=2.2\mu F$, $C_O=1\mu F$)

PARAMETER	SYMBOL	TEST CONDITIONS	MIN	TYP	MAX	UNIT
Output Voltage	V_{OUT}	$T_J=25^\circ C$	-7.68	-8.0	-8.32	V
		$5.0mA < I_{OUT} < 0.5A$, $P_{OUT} < 15W$ $V_{IN} = -10.5V \sim -23V$	-7.60		-8.40	V
Line Regulation	ΔV_{OUT}	$T_J=25^\circ C$, $V_{IN} = -10.5V \sim -25V$		10	100	mV
		$T_J=25^\circ C$, $V_{IN} = -11.5V \sim -17V$		5	80	mV
Load Regulation	ΔV_{OUT}	$T_J=25^\circ C$, $I_{OUT} = 5.0mA \sim 0.5A$		12	160	mV
		$T_J=25^\circ C$, $I_{OUT} = 5.0mA \sim 200mA$		4	80	mV
Quiescent Current	I_Q	$T_J=25^\circ C$		4.3	8	mA
Quiescent Current change	ΔI_Q	$I_{OUT} = 5mA \sim 0.5A$		0.05	0.5	mA
		$V_{IN} = -11.5V \sim -25V$		0.1	1.0	mA
Temperature Coefficient of V_{OUT}	$\Delta V_{OUT}/\Delta T$	$I_{OUT} = 5mA$		-0.6		mV/ $^\circ C$
Output Noise Voltage	eN	$f = 10Hz \sim 100kHz$, $T_a = 25^\circ C$		175		μV
Ripple Rejection	RR	$f = 120Hz$, $V_{IN} = -11.5V \sim -21.5V$	54	60		dB
Dropout Voltage	V_D	$I_{OUT} = 0.5A$, $T_J = 25^\circ C$		2		V

FOR 79D09 ($V_{IN}=-15V$, $I_{OUT}=500mA$, $C_I=2.2\mu F$, $C_O=1\mu F$)

PARAMETER	SYMBOL	TEST CONDITIONS	MIN	TYP	MAX	UNIT
Output Voltage	V_{OUT}	$T_J=25^\circ C$	-8.64	-9.0	-9.36	V
		$5.0mA < I_{OUT} < 0.5A$, $P_{OUT} < 15W$ $V_{IN} = -11.5V \sim -24V$	-8.55		-9.45	V
Line regulation	ΔV_{OUT}	$T_J=25^\circ C$, $V_{IN} = -11.5V \sim -25V$		10	180	mV
		$T_J=25^\circ C$, $V_{IN} = -12.5V \sim -18V$		5	90	mV
Load Regulation	ΔV_{OUT}	$T_J=25^\circ C$, $I_{OUT} = 5.0mA \sim 0.5A$		12	180	mV
		$T_J=25^\circ C$, $I_{OUT} = 5.0mA \sim 200mA$		4	90	mV
Quiescent Current	I_Q	$T_J=25^\circ C$		4.3	8	mA
Quiescent Current Change	ΔI_Q	$I_{OUT} = 5mA \sim 0.5A$		0.05	0.5	mA
		$V_{IN} = -11.5V \sim -26V$		0.1	1.0	mA
Temperature Coefficient of V_{OUT}	$\Delta V_{OUT}/\Delta T$	$I_{OUT} = 5mA$		-0.6		mV/ $^\circ C$
Output Noise Voltage	eN	$f = 10Hz \sim 100kHz$, $T_a = 25^\circ C$		175		μV
Ripple Rejection	RR	$f = 120Hz$, $V_{IN} = -12.5V \sim -22.5V$	54	60		dB
Dropout Voltage	V_D	$I_{OUT} = 0.5A$, $T_J = 25^\circ C$		2		V

FOR 79D12 ($V_{IN}=-18V$, $I_{OUT}=500mA$, $C_I=2.2\mu F$, $C_O=1\mu F$)

PARAMETER	SYMBOL	TEST CONDITIONS	MIN	TYP	MAX	UNIT
Output Voltage	V_{OUT}	$T_J=25^\circ C$	-11.52	-12.0	-12.48	V
		$5.0mA < I_{OUT} < 0.5A$, $P_{OUT} < 15W$ $V_{IN} = -14.5V \sim -27V$	-11.40		-12.60	V
Line Regulation	ΔV_{OUT}	$T_J=25^\circ C$, $V_{IN} = -14.5V \sim -30V$		12	240	mV
		$T_J=25^\circ C$, $V_{IN} = -16V \sim -22V$		6	120	mV
Load Regulation	ΔV_{OUT}	$T_J=25^\circ C$, $I_{OUT} = 5.0mA \sim 0.5A$		12	240	mV
		$T_J=25^\circ C$, $I_{OUT} = 5.0mA \sim 200mA$		4	120	mV
Quiescent Current	I_Q	$T_J=25^\circ C$		4.3	8	mA
Quiescent Current Change	ΔI_Q	$I_{OUT} = 5mA \sim 0.5A$		0.05	0.5	mA
		$V_{IN} = -14.5V \sim -30V$		0.1	1.0	mA
Temperature Coefficient of V_{OUT}	$\Delta V_{OUT}/\Delta T$	$I_{OUT} = 5mA$		-0.8		mV/ $^\circ C$
Output Noise Voltage	eN	$f = 10Hz \sim 100kHz$, $T_a = 25^\circ C$		200		μV
Ripple Rejection	RR	$f = 120Hz$, $V_{IN} = -15V \sim -25V$	54	60		dB
Dropout Voltage	V_D	$I_{OUT} = 0.5A$, $T_J = 25^\circ C$		2		V

■ ELECTRICAL CHARACTERISTICS(Cont.)

FOR 79D15 ($V_{IN}=-23V$, $I_{OUT}=500mA$, $C_I=2.2\mu F$, $C_O=1\mu F$)

PARAMETER	SYMBOL	TEST CONDITIONS	MIN	TYP	MAX	UNIT
Output Voltage	V_{OUT}	$T_J=25^\circ C$	-14.40	-15.0	-15.60	V
		$5.0mA < I_{OUT} < 0.5A$, $P_{OUT} < 15W$ $V_i = -17.5V \sim -30V$	-14.25		-15.75	V
Line Regulation	ΔV_{OUT}	$T_J=25^\circ C$, $V_{IN}=-17.5V \sim -30V$		12	300	mV
		$T_J=25^\circ C$, $V_{IN}=-20V \sim -26V$		6	150	mV
Load Regulation	ΔV_{OUT}	$T_J=25^\circ C$, $I_{OUT}=5.0mA \sim 0.5A$		12	300	mV
		$T_J=25^\circ C$, $I_{OUT}=5.0mA \sim 200mA$		4	150	mV
Quiescent Current	I_Q	$T_J=25^\circ C$		4.3	8	mA
Quiescent Current Change	ΔI_Q	$I_{OUT}=5mA \sim 0.5A$		0.05	0.5	mA
		$V_{IN}=-17.5V \sim -30.5V$		0.1	1.0	MA
Temperature Coefficient of V_{OUT}	$\Delta V_{OUT}/\Delta T$	$I_{OUT}=5mA$		-0.9		mV/ $^\circ C$
Output Noise Voltage	eN	$f=10Hz \sim 100kHz$, $T_a=25^\circ C$		250		μV
Ripple Rejection	RR	$f=120Hz$, $V_{IN}=-18.5V \sim -28.5V$	54	60		dB
Dropout Voltage	V_d	$I_{OUT}=0.5A$, $T_J=25^\circ C$		2		V

FOR 79D18 ($V_{IN}=-27V$, $I_{OUT}=500mA$, $C_I=2.2\mu F$, $C_O=1\mu F$)

PARAMETER	SYMBOL	TEST CONDITIONS	MIN	TYP	MAX	UNIT
Output Voltage	V_{OUT}	$T_J=25^\circ C$	-17.28	-18.0	-18.72	V
		$5.0mA < I_{OUT} < 0.5A$, $P_{OUT} < 15W$ $V_{IN}=-21V \sim -33V$	-17.10		-18.90	V
Line Regulation	ΔV_{OUT}	$T_J=25^\circ C$, $V_{IN}=-21V \sim -33V$		15	360	mV
		$T_J=25^\circ C$, $V_{IN}=-24V \sim -30V$		8	180	mV
Load Regulation	ΔV_{OUT}	$T_J=25^\circ C$, $I_{OUT}=5.0mA \sim 0.5A$		15	360	mV
		$T_J=25^\circ C$, $I_{OUT}=5.0mA \sim 200mA$		5.0	180	mV
Quiescent Current	I_Q	$T_J=25^\circ C$		4.3	8	mA
Quiescent Current Change	ΔI_Q	$I_{OUT}=5mA \sim 0.5A$			0.5	mA
		$V_{IN}=-21V \sim -32V$			1.0	mA
Temperature Coefficient of V_{OUT}	$\Delta V_{OUT}/\Delta T$	$I_{OUT}=5mA$		-1		mV/ $^\circ C$
Output Noise Voltage	eN	$f=10Hz \sim 100kHz$, $T_a=25^\circ C$		300		μV
Ripple Rejection	RR	$f=120Hz$, $V_{IN}=-22V \sim -32V$	54	60		dB
Dropout Voltage	V_D	$I_{OUT}=0.5A$, $T_J=25^\circ C$		2		V

FOR 79D24 ($V_{IN}=-33V$, $I_{OUT}=500mA$, $C_I=2.2\mu F$, $C_O=1\mu F$)

PARAMETER	SYMBOL	TEST CONDITIONS	MIN	TYP	MAX	UNIT
Output Voltage	V_{OUT}	$T_J=25^\circ C$	-23.04	-24.0	-24.96	V
		$5.0mA < I_{OUT} < 0.5A$, $P_{OUT} < 15W$ $V_{IN}=-27V \sim -38V$	-22.80		-25.20	V
Line Regulation	ΔV_{OUT}	$T_J=25^\circ C$, $V_{IN}=-27V \sim -38V$		15	480	mV
		$T_J=25^\circ C$, $V_{IN}=-30V \sim -36V$		8	240	mV
Load Regulation	ΔV_{OUT}	$T_J=25^\circ C$, $I_{OUT}=5.0mA \sim 0.5A$		15	480	mV
		$T_J=25^\circ C$, $I_{OUT}=5.0mA \sim 200mA$		5.0	240	mV
Quiescent Current	I_Q	$T_J=25^\circ C$		4.3	8	mA
Quiescent Current Change	ΔI_Q	$I_{OUT}=5mA \sim 0.5A$			0.5	mA
		$V_{IN}=-27V \sim -38V$			1.0	mA
Temperature Coefficient of V_{OUT}	$\Delta V_{OUT}/\Delta T$	$I_{OUT}=5mA$		-1		mV/ $^\circ C$
Output Noise Voltage	eN	$f=10Hz \sim 100kHz$, $T_a=25^\circ C$		400		μV
Ripple Rejection	RR	$f=120Hz$, $V_{IN}=-28V$ to $-38V$	54	60		dB
Dropout Voltage	V_D	$I_{OUT}=0.5A$, $T_J=25^\circ C$		2		V

APPLICATION CIRCUITS

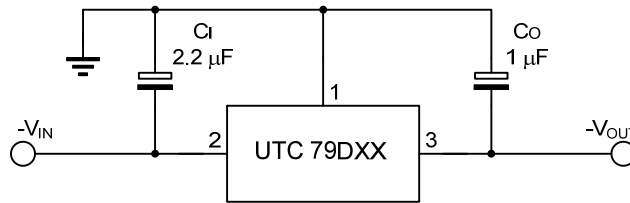

Fig.1 Fixed output regulator

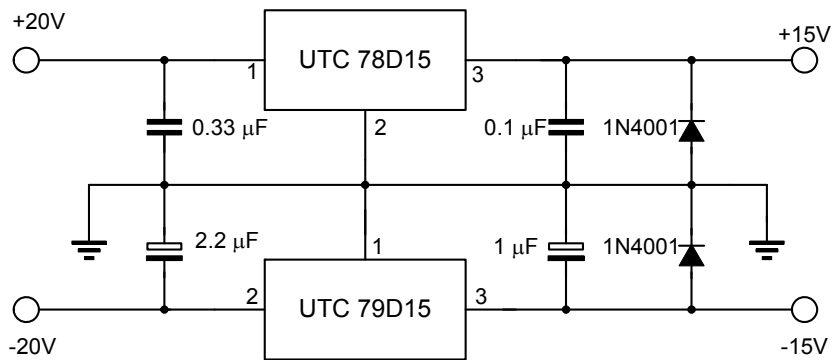

Fig.2 Split power supply ($\pm 15V$, 0.5A)

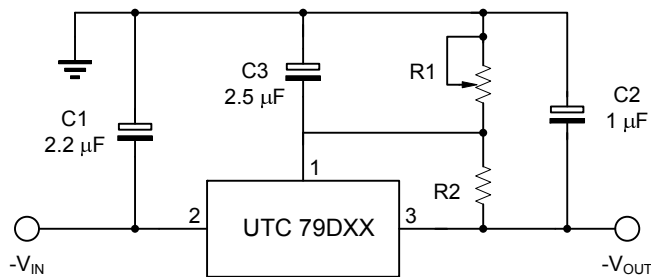

Fig.3 Circuit for increasing output voltage

UTC assumes no responsibility for equipment failures that result from using products at values that exceed, even momentarily, rated values (such as maximum ratings, operating condition ranges, or other parameters) listed in products specifications of any and all UTC products described or contained herein. UTC products are not designed for use in life support appliances, devices or systems where malfunction of these products can be reasonably expected to result in personal injury. Reproduction in whole or in part is prohibited without the prior written consent of the copyright owner. The information presented in this document does not form part of any quotation or contract, is believed to be accurate and reliable and may be changed without notice.

X-ON Electronics

Largest Supplier of Electrical and Electronic Components

Click to view similar products for [Linear Voltage Regulators](#) category:

Click to view products by [Unisonic](#) manufacturer:

Other Similar products are found below :

[LV56831P-E](#) [LV5684PVD-XH](#) [MCDTSA6-2R](#) [L4953G](#) [L7815ACV-DG](#) [PQ3DZ53U](#) [LV56801P-E](#) [TCR3DF13,LM\(CT](#)
[TCR3DF39,LM\(CT](#) [TLE42794G](#) [L78L05CZ/1SX](#) [L78LR05DL-MA-E](#) [L78MR05-E](#) [033150D](#) [033151B](#) [090756R](#) [636416C](#)
[NCV78M15BDTG](#) [702482B](#) [714954EB](#) [TLE42794GM](#) [TLE42994GM](#) [ZMR500QFTA](#) [BA033LBSG2-TR](#) [NCV78M05ABDTRKG](#)
[NCV78M08BDTRKG](#) [NCP7808TG](#) [NCV571SN12T1G](#) [LV5680P-E](#) [CAJ24C256YI-GT3](#) [L78M15CV-DG](#) [L9474N](#)
[TLS202B1MBV33HTSA1](#) [L79M05T-E](#) [NCP571SN09T1G](#) [MAX15006AASA/V+](#) [MIC5283-5.0YML-T5](#) [L4969URTR-E](#) [L78LR05D-MA-E](#)
[NCV7808BDTRKG](#) [L9466N](#) [NCP7805ETG](#) [SC7812CTG](#) [NCV7809BTG](#) [NCV571SN09T1G](#) [NCV317MBTG](#) [MC78M15CDTT5G](#)
[MC78M12CDTT5G](#) [L9468N](#) [LT1054IS8#TRPBF](#)