



# KA22241

## LINEAR INTEGRATED CIRCUIT

### DUAL EQUALIZER AMPLIFIER WITH ALC

■ DESCRIPTION

The UTC **KA22241** is a monolithic integrated circuit, consisting of dual equalizer amplifier with ALC, and it is suitable for stereo radio cassette tape recorders.

■ FEATURES

- \* Dual equalizer amplifier with built-in ALC circuit
- \* Low noise  $V_{NI}=1.0\mu V$ (Typical)
- \* High open loop voltage gain:  $G_v=80dB$ (Typical)
- \* Good ALC response balance between channels
- \* Not necessary the input coupling capacitor
- \* Not necessary the diode or transistor for ALC
- \* Built in power supply muting circuit
- \* Minimum number of external parts required

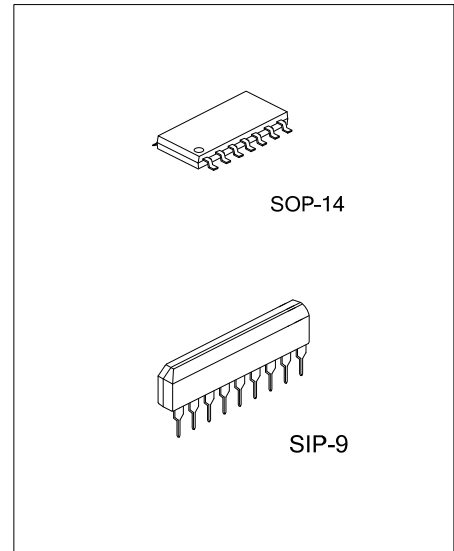

■ ORDERING INFORMATION

Ordering Number	Package	Packing
KA22241G-G09-T	SIP-9	Tube
KA22241G-S14-R	SOP-14	Tape Reel

<p>KA22241G-G09-T</p> <p>(1)Packing Type (2)Package Type (3)Green Package</p>	<p>(1) R: Tape Reel, T: Tube (2) G09: SIP-9, S14: SOP-14 (3) G: Halogen Free and Lead Free</p>
---	--

■ MARKING

SIP-9	SOP-14
<p>UTC □□□□ → Data Code KA22241G □□ → Lot Code</p> <p>1 2 3 4 5 6 7 8 9</p>	<p>14 13 12 11 10 9 8 → Date Code UTC □□□□ KA22241G □□ → Lot Code</p> <p>1 2 3 4 5 6 7</p>

■ BLOCK DIAGRAM

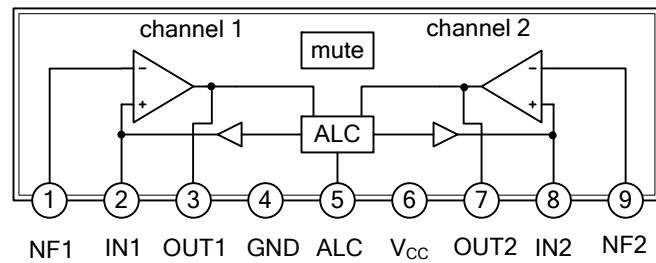

SIP-9

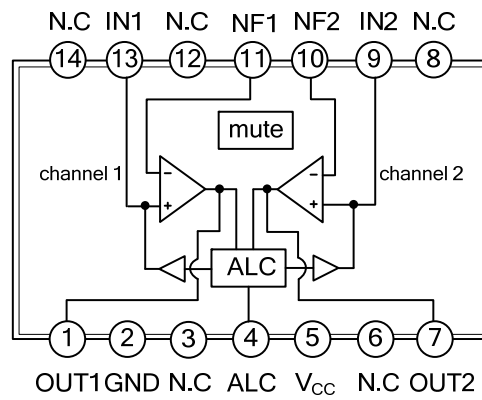

SOP-14

■ ABSOLUTE MAXIMUM RATING ( $T_A = 25^\circ\text{C}$ )

PARAMETER	SYMBOL	RATINGS	UNIT
Supply Voltage	$V_{CC}$	16	V
Power Dissipation	SIP-9	550	mW
	SOP-14	450	
Operating Temperature	$T_{OPR}$	-20 ~ 75	$^\circ\text{C}$
Storage Temperature	$T_{STG}$	-20 ~ 125	$^\circ\text{C}$

Note: Absolute maximum ratings are those values beyond which the device could be permanently damaged.

Absolute maximum ratings are stress ratings only and functional device operation is not implied.

■ ELECTRICAL CHARACTERISTICS ( $T_A = 25^\circ\text{C}$ ,  $V_{CC}=7\text{V}$ ,  $f=1\text{KHZ}$ , unless otherwise specified)

PARAMETER	SYMBOL	TEST CONDITIONS	MIN	TYP	MAX	UNIT
Input Noise Voltage	$V_{IN}$	$R_G=2.2\text{K}\Omega$ $BW(-3\text{dB})=20\text{HZ}\sim 20\text{KHZ}$		1.0	2.0	$\mu\text{V}$
Output Voltage	$V_{OUT}$	THD=1%	0.6	1.2		V
Quiescent Circuit Current	$I_{CCQ}$	$V_{IN}=0$	1.5	3.5	4.5	mA
Open Loop Voltage Gain	$G_{VO}$	$V_{OUT}=0.3\text{V}$	70	80		dB
Closed Loop Voltage Gain	$G_{VC}$	$V_{OUT}=0.3\text{V}$	45	48	50	dB
ALC Range	$\Delta V_{ALC}$	$R_O=3.9\text{K}\Omega$ , THD=10%	40	45		dB
ALC Balance	$CB_{ALC}$	$V_{IN}=1\text{mV}$		0	2.5	dB
Total Harmonic Distortion	THD	$V_{OUT}=0.3\text{V}$		0.1	0.3	%
Input Resistance	$R_{IN}$		15	25	45	$\text{k}\Omega$

### ■ TEST CIRCUIT

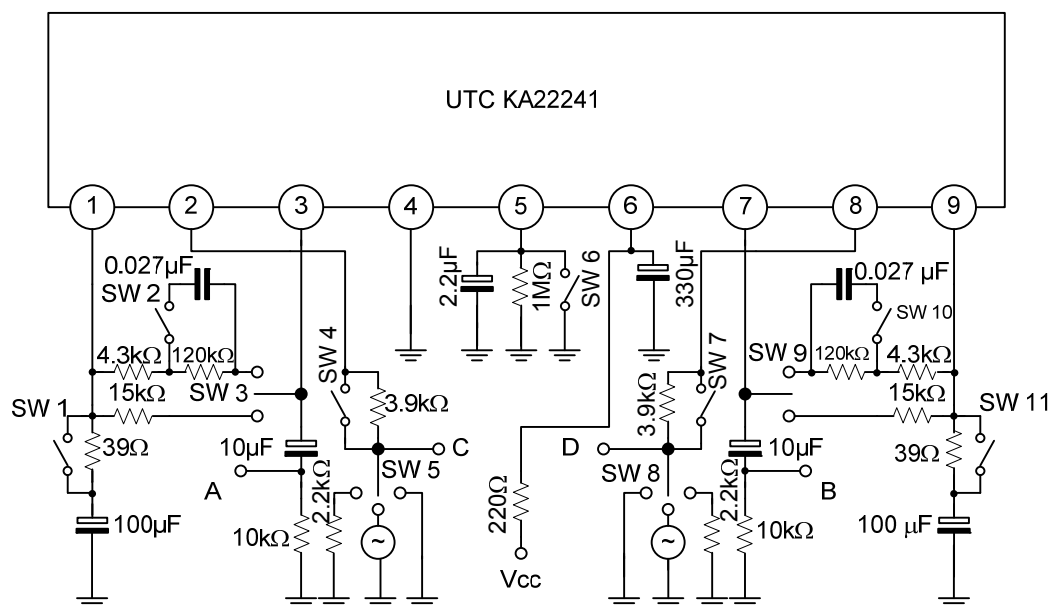

### TEST METHOD

SYMBOL	SW1	SW2	SW3	SW4	SW5	SW6	SW7	SW8	SW9	SW10	SW11
$I_{CCQ}$	ON	OFF	1	ON	3	ON	ON	3	1	OFF	ON
$G_{VO}$	ON	OFF	1	ON	1	ON	ON	3	1	OFF	ON
$G_{VC}$	OFF	ON	1	ON	1	ON	ON	3	1	OFF	ON
THD	OFF	ON	1	ON	1	ON	ON	3	1	OFF	ON
$V_{OUT}$	OFF	ON	1	ON	1	ON	ON	3	1	OFF	ON
$V_{NI-1}$	OFF	ON	1	ON	2	ON	ON	3	1	OFF	ON
$V_{NI-2}$	ON	OFF	1	ON	3	ON	ON	2	1	ON	OFF
$\Delta V_{ALC}$	OFF	OFF	2	OFF	1	OFF	ON	3	1	OFF	ON
$CB_{ALC}$	OFF	OFF	2	OFF	1	OFF	OFF	1	2	OFF	OFF

■ TYPICAL APPLICATION CIRCUIT

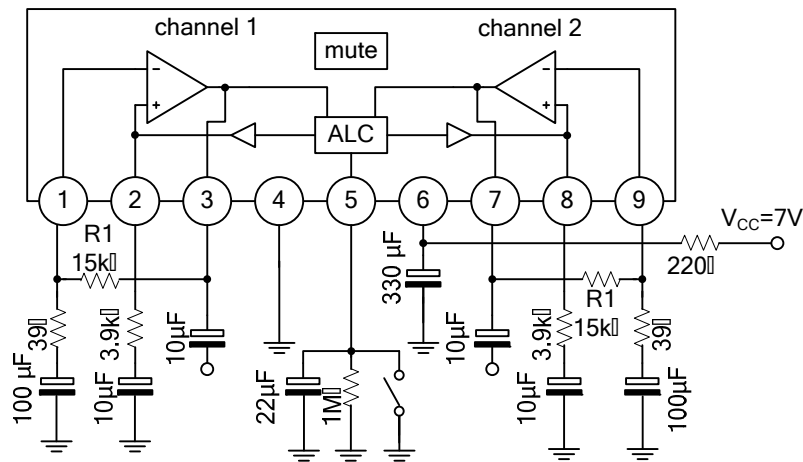

Note: On playback, connect the time constant circuit as follows below, instead of R1 of PINS 1, 3, 7, 9, which are used in the NAB.

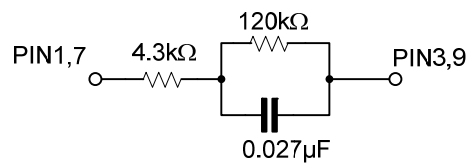

### TYPICAL CHARACTERISTICS

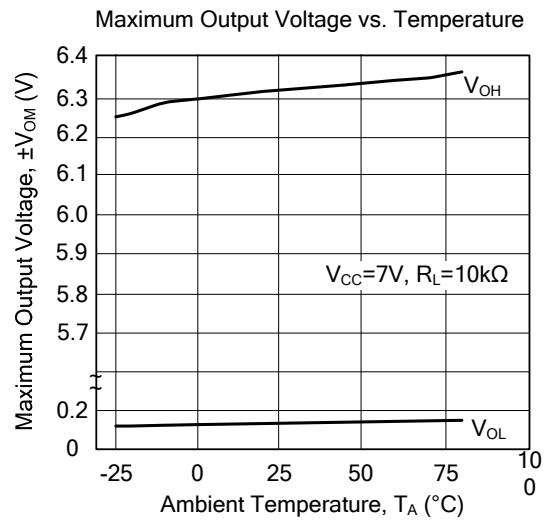
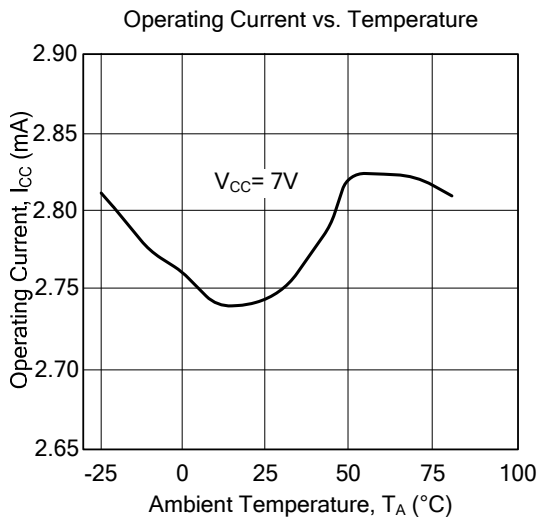

UTC assumes no responsibility for equipment failures that result from using products at values that exceed, even momentarily, rated values (such as maximum ratings, operating condition ranges, or other parameters) listed in products specifications of any and all UTC products described or contained herein. UTC products are not designed for use in life support appliances, devices or systems where malfunction of these products can be reasonably expected to result in personal injury. Reproduction in whole or in part is prohibited without the prior written consent of the copyright owner. The information presented in this document does not form part of any quotation or contract, is believed to be accurate and reliable and may be changed without notice.

## X-ON Electronics

Largest Supplier of Electrical and Electronic Components

*Click to view similar products for [Operational Amplifiers - Op Amps](#) category:*

*Click to view products by [Unisonic](#) manufacturer:*

Other Similar products are found below :

[430227FB](#) [AZV831KTR-G1](#) [UPC824G2-A](#) [LT1678IS8](#) [042225DB](#) [058184EB](#) [UPC822G2-A](#) [UPC258G2-A](#) [NCS5651MNTXG](#)  
[NCV33202DMR2G](#) [NJM324E](#) [NTE925](#) [5962-9080901MCA\\*](#) [AP4310AUMTR-AG1](#) [HA1630D02MMEL-E](#) [HA1630S01LPEL-E](#)  
[SCY33178DR2G](#) [NJU77806F3-TE1](#) [NCV5652MUTWG](#) [NCV20034DR2G](#) [LM2902EDR2G](#) [NTE778S](#) [NTE871](#) [NTE924](#) [NTE937](#)  
[MCP6V16UT-E/OT](#) [MCP6V17T-E/MS](#) [MCP6V19T-E/ST](#) [SCY6358ADR2G](#) [LTC2065IUD#PBF](#) [NCS20282FCTTAG](#) [UPC4741G2-E1-A](#)  
[LM4565FVT-GE2](#) [EL5420CRZ-T7A](#) [TSV791IYLT](#) [TSV772IQ2T](#) [AS324AMTR-E1](#) [TLV2772QPWR](#) [NJM4556AM-TE1](#) [NJM2068M-TE1](#)  
[AS324MTR-E1](#) [AS358MMTR-G1](#) [MCP6232T-EMNY](#) [MCP662-E/MF](#) [TLC081AIP](#) [TLC082AIP](#) [TLE2074ACDW](#) [TLV07IDR](#)  
[TLV2170IDGKT](#) [TLV2455IDR](#)