



# LM317A

## LINEAR INTEGRATED CIRCUIT

### MEDIUM CURRENT 1.2V TO 37V ADJUSTABLE VOLTAGE REGULATOR

■ DESCRIPTION

The UTC **LM317A** is an adjustable 3-terminal positive voltage regulator, designed to supply 1.5A of output current with voltage adjustable from 1.2V ~ 37V.

■ FEATURES

- \* Output voltage adjustable from 1.2V ~ 37V
- \* Output current in excess of 1.5A
- \* Internal thermal overload protection
- \* Internal short circuit current limiting
- \* Output transistor safe area compensation

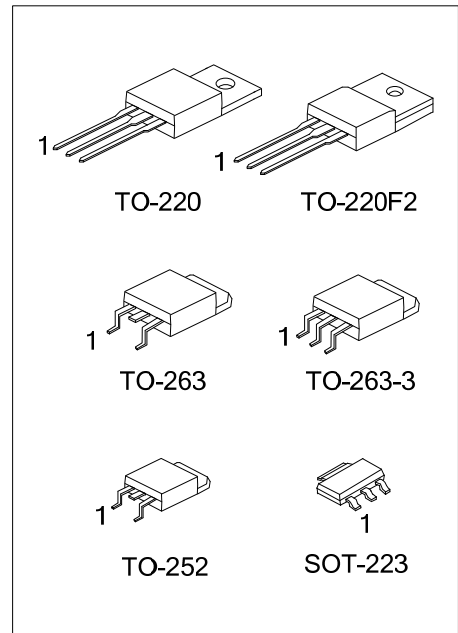

■ ORDERING INFORMATION

Ordering Number		Package	Pin Assignment			Packing
Lead Free	Halogen Free		1	2	3	
-	LM317AG-AA3-R	SOT-223	ADJ	O	I	Tape Reel
LM317AL-TA3-T	LM317AG-TA3-T	TO-220	ADJ	O	I	Tube
LM317AL-TF2-T	LM317AG-TF2-T	TO-220F2	ADJ	O	I	Tube
LM317AL-TN3-R	LM317AG-TN3-R	TO-252	ADJ	O	I	Tape Reel
LM317AL-TQ2-R	LM317AG-TQ2-R	TO-263	ADJ	O	I	Tape Reel
LM317AL-TQ2-T	LM317AG-TQ2-T	TO-263	ADJ	O	I	Tube
LM317AL-TQ3-R	LM317AG-TQ3-R	TO-263-3	ADJ	O	I	Tape Reel
LM317AL-TQ3-T	LM317AG-TQ3-T	TO-263-3	ADJ	O	I	Tube

Note: Pin Assignment: I:  $V_{IN}$  O:  $V_{OUT}$

<p>LM317AG-AA3-R</p>	<p>(1) R: Tape Reel, T: Tube                  (2) AA3: SOT-223, TA3: TO-220, TF2: TO-220F2                  TN3: TO-252, TQ2: TO-263, TQ3: TO-263-3                  (3) G: Halogen Free and Lead Free, L: Lead Free</p>
----------------------	--

■ MARKING

SOT-223	TO-220 / TO-220F2 / TO-252 / TO-263 / TO-263-3

■ BLOCK DIAGRAM

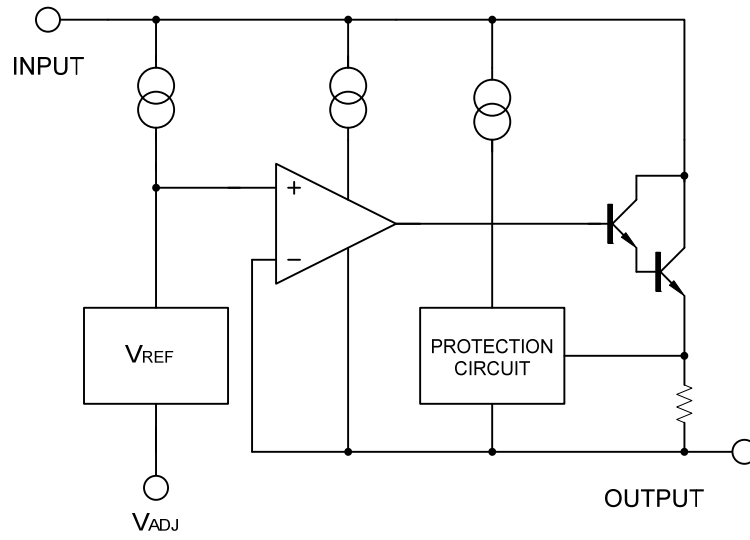

### ■ ABSOLUTE MAXIMUM RATINGS

PARAMETER	SYMBOL	RATINGS	UNIT
Input-Output Voltage Differential	$V_{IN}-V_{OUT}$	40	V
Power Dissipation	$P_D$	Internally limited	
Junction Temperature	$T_J$	+125	°C
Operating Temperature	$T_{OPR}$	-40 ~ +85	°C
Storage Temperature	$T_{STG}$	-65 ~ +150	°C

Note: Absolute maximum ratings are those values beyond which the device could be permanently damaged.

Absolute maximum ratings are stress ratings only and functional device operation is not implied.

### ■ THERMAL DATA

PARAMETER	SYMBOL	RATINGS	UNIT
Junction to Ambient	SOT-223	140	°C/W
	TO-220/TO-220F2	50	°C/W
	TO-252	103	°C/W
	TO-263/TO-263-3	62.5	°C/W
Junction to Case	SOT-223	23.5	°C/W
	TO-220/TO-263	5	°C/W
	TO-263-3	8	°C/W
	TO-220F2	12	°C/W

### ■ ELECTRICAL CHARACTERISTICS

( $V_{IN}-V_{OUT}=5V$ ,  $I_{OUT}=0.5A$ ,  $P_{MAX}=20W$ ,  $T_A=25^{\circ}C$ , unless otherwise specified.)

PARAMETER	SYMBOL	TEST CONDITIONS	MIN	TYP	MAX	UNIT	
Line Regulation	$\Delta V_{OUT}/V_{OUT}$	$3V \leq V_{IN}-V_{OUT} \leq 40V$ , $I_{OUT}=100mA$		0.01	0.04	%/V	
Load Regulation	$\Delta V_{OUT}$	$10mA \leq I_{OUT} \leq 1.5A$	$V_{OUT} \leq 5V$	5	25	mV	
			$V_{OUT} \geq 5V$	0.1	0.5	%	
Adjustable Pin Current	$I_{ADJ}$			50	100	$\mu A$	
Adjustable Pin Current Change	$\Delta I_{ADJ}$	$3V \leq V_{IN}-V_{OUT} \leq 40V$ , $10mA \leq I_{OUT} \leq 500mA$		0.2	5	$\mu A$	
Reference Voltage	$V_{REF}$	$3V \leq V_{IN}-V_{OUT} \leq 40V$ , $10mA \leq I_{OUT} \leq 1.5A$ , $P_D < P_{MAX}$	1.20	1.25	1.30	V	
Temperature Stability		$T_{MIN} \leq T_J \leq T_{MAX}$		0.7		%/V <sub>OUT</sub>	
Minimum Load Current for Regulation	$I_{L(MIN)}$	$V_{IN}-V_{OUT}=40V$			4.5	mA	
Maximum Output Current	$I_{O(MAX)}$	$V_{IN}-V_{OUT}=40V$ , $P_D \leq P_{MAX}$	0.3	0.4		A	
		$V_{IN}-V_{OUT}=15V$ , $P_D < P_{MAX}$	1.5	2.2		A	
RMS Noise vs. %of $V_{OUT}$	eN	$10Hz \leq f \leq 10KHz$		0.003		%/V <sub>OUT</sub>	
Ripple Rejection	RR	$V_{OUT}=10V$ , $f=120Hz$	$C_{ADJ}=0$		65		dB
			$C_{ADJ}=10\mu F$	66	80		dB

## APPLICATION CIRCUITS

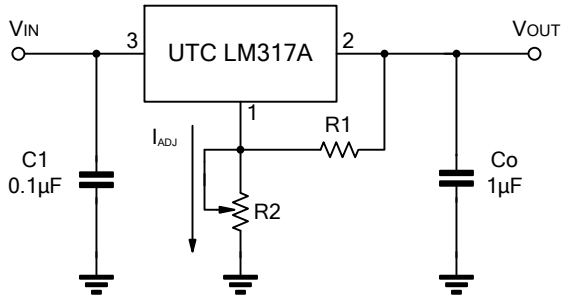

$$V_{OUT} = 1.25V \times (1 + R2/R1) + I_{ADJ} \times R2$$

C1 is required when regulator is located an appreciated distance from power supply. Co is needed to improve transient response.

**Fig.1 Programmable voltage regulator**

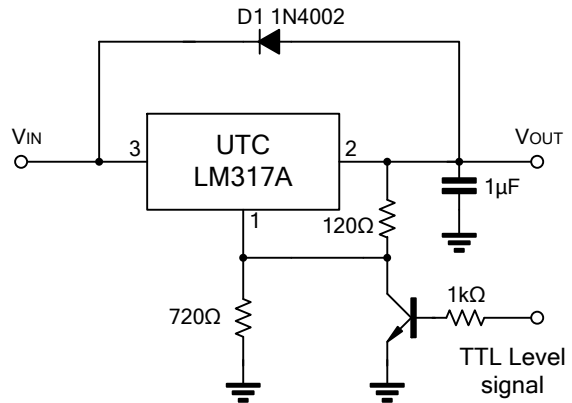

**Fig.2 Regulator with On-off control**

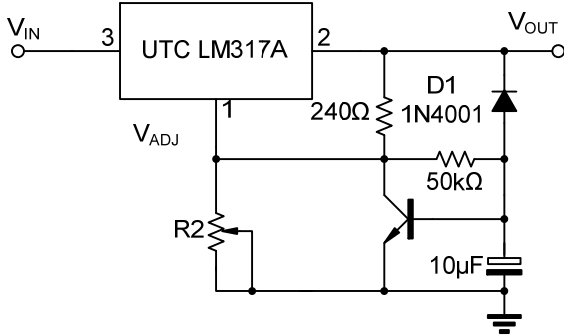

**Fig.3 Soft Start Application**

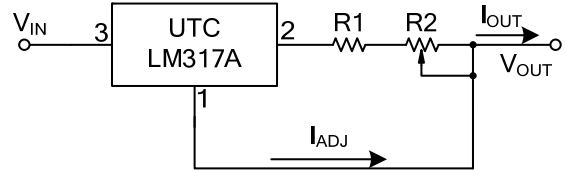

$$I_{O(MAX)} = \left( \frac{V_{REF}}{R1} \right) + I_{ADJ} = \frac{1.25V}{R1}$$

$$I_{O(MIN)} = \left( \frac{V_{REF}}{R1+R2} \right) + I_{ADJ} = \frac{1.25V}{R1+R2}$$

**Fig.4 Constant Current Application**

### TYPICAL CHARACTERISTICS

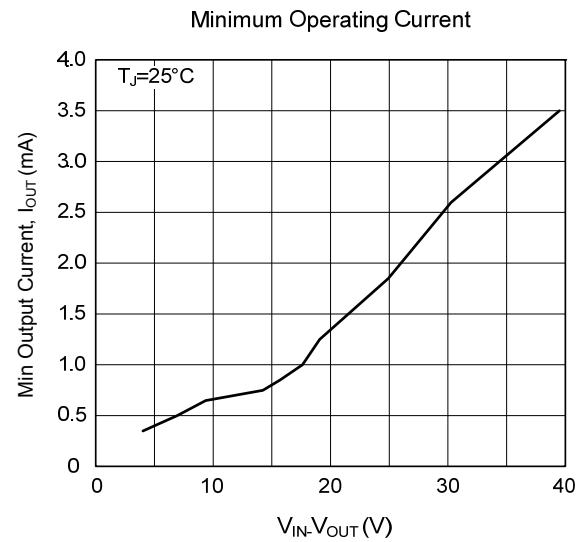
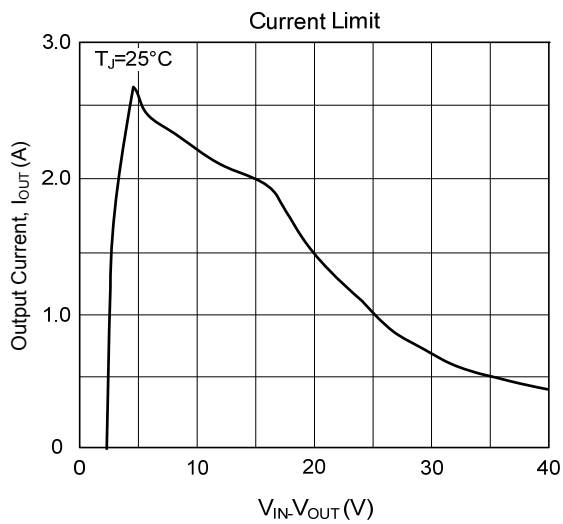
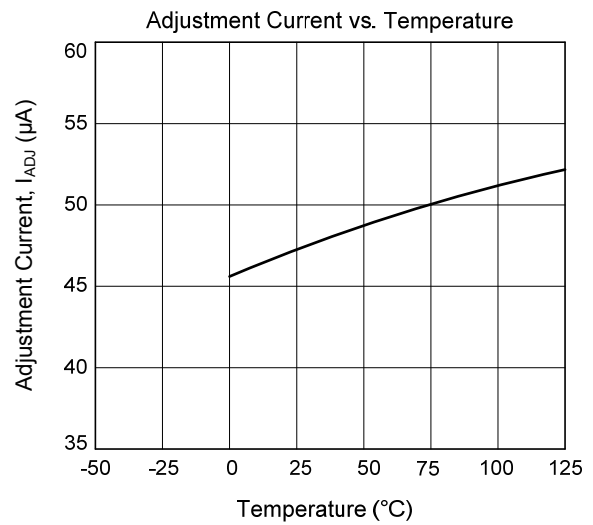
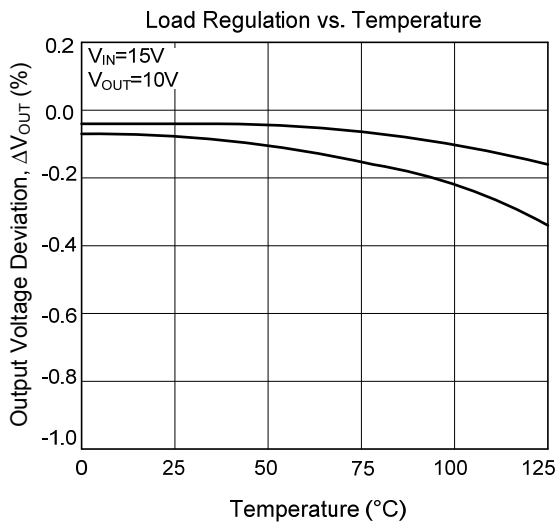

UTC assumes no responsibility for equipment failures that result from using products at values that exceed, even momentarily, rated values (such as maximum ratings, operating condition ranges, or other parameters) listed in products specifications of any and all UTC products described or contained herein. UTC products are not designed for use in life support appliances, devices or systems where malfunction of these products can be reasonably expected to result in personal injury. Reproduction in whole or in part is prohibited without the prior written consent of the copyright owner. The information presented in this document does not form part of any quotation or contract, is believed to be accurate and reliable and may be changed without notice.

## X-ON Electronics

Largest Supplier of Electrical and Electronic Components

*Click to view similar products for [Switching Voltage Regulators](#) category:*

*Click to view products by [Unisonic](#) manufacturer:*

Other Similar products are found below :

[FAN53610AUC33X](#) [FAN53611AUC123X](#) [MP2374DS-LF-Z](#) [EN6310QA](#) [NCP81108MNTXG](#) [NCP81109BMNTXG](#) [FAN48610BUC45X](#)  
[FAN48617UC50X](#) [R3](#) [KE177614](#) [MPQ4423GQ-AEC1-Z](#) [FAN53611AUC12X](#) [MAX809TTR](#) [NCV891234MW50R2G](#) [AST1S31PUR](#)  
[NCP81103MNTXG](#) [NCP81203PMNTXG](#) [NCP81208MNTXG](#) [NCP81109GMNTXG](#) [SCY1751FCCT1G](#) [NCP81109JMNTXG](#) [MP2161AGJ-](#)  
[Z](#) [NCP81241MNTXG](#) [MP2388GQEU-Z](#) [MPQ4481GU-AEC1-P](#) [MP8756GD-P](#) [MPQ2171GJ-P](#) [MPQ2171GJ-AEC1-P](#) [MP2171GJ-P](#)  
[NCV1077CSTBT3G](#) [MP28160GC-Z](#) [MPM3509GQVE-AEC1-P](#) [LTM4691EV#PBF](#) [XCL207A123CR-G](#) [XDPE132G5CG000XUMA1](#)  
[XDPE12284C0000XUMA1](#) [LTM4691IV#PBF](#) [MP5461GC-P](#) [MP28301GG-P](#) [MIC23356YFT-TR](#) [ISL95338IRTZ](#) [MP3416GJ-P](#)  
[BD9S201NUX-CE2](#) [ISL9113AIRAZ-T](#) [MP5461GC-Z](#) [MPQ2172GJ-AEC1-Z](#) [MPQ4415AGQB-Z](#) [MPQ4590GS-Z](#)  
[IR3888AMTRPBFAUMA1](#) [MPQ4409GQBE-AEC1-P](#)