



LM78XXA

LINEAR INTEGRATED CIRCUIT

3-TERMINAL 1.5A POSITIVE VOLTAGE REGULATOR

■ DESCRIPTION

The UTC **LM78XXA** family is monolithic fixed voltage regulator integrated circuit. They are suitable for applications requiring supply current up to 1.5 A.

■ FEATURES

- * Output current up to 1.5A
- * Fixed output voltage of 5V, 6V, 7V, 8V, 9V, 10V, 12V, 15V, 18V and 24V available
- * Thermal overload shutdown protection
- * Output transistor SOA protection

■ ORDERING INFORMATION

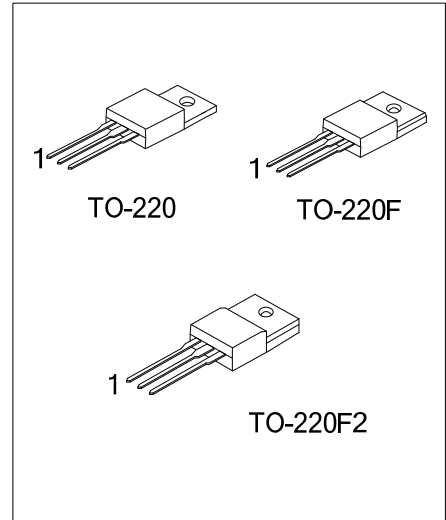

Ordering Number		Package	Pin Assignment			Packing
Lead Free	Halogen Free		1	2	3	
LM78XXAL-TA3-T	LM78XXAG-TA3-T	TO-220	I	G	O	Tube
LM78XXAL-TF3-T	LM78XXAG-TF3-T	TO-220F	I	G	O	Tube
LM78XXAL-TF2-T	LM78XXAG-TF2-T	TO-220F2	I	G	O	Tube

Note: Pin Assignment: O: Output G: GND I: Input

<p>LM78XXAL-TA3-T</p>	<p>(1) Packing Type (2) Package Type (3) Green Package (4) Output Voltage Code</p>	<p>(1) T: Tube (2) TA3: TO-220, TF3: TO-220F, TF2: TO-220F2 (3) L: Lead Free, G: Halogen Free and Lead Free (4) XX: refer to Marking Information</p>
-----------------------	--	--

■ MARKING INFORMATION

PACKAGE	VOLTAGE CODE	MARKING
TO-220	05: 5.0 V 06: 6.0 V 07: 7.0 V 08: 8.0 V	<p>L: Lead Free G: Halogen Free</p>
TO-220F	09: 9.0 V 10: 10 V	
TO-220F2	12: 12 V 15: 15 V 18: 18 V 24: 24 V	

■ TEST CIRCUIT

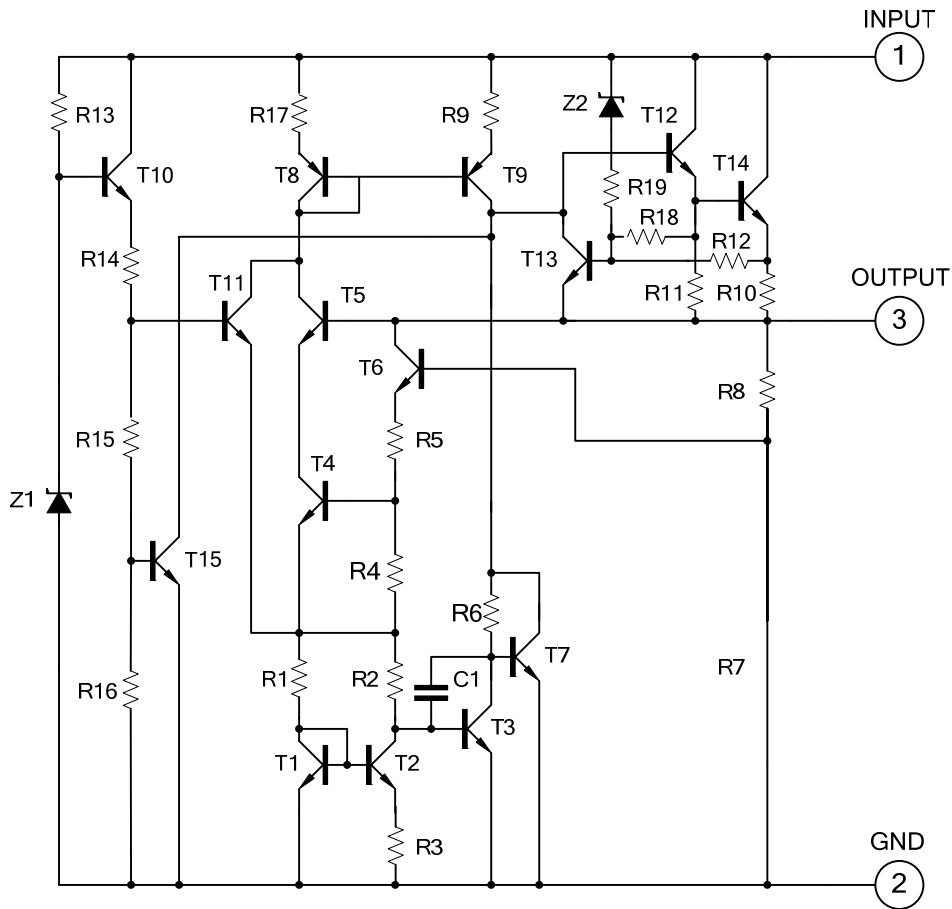

■ APPLICATION CIRCUIT

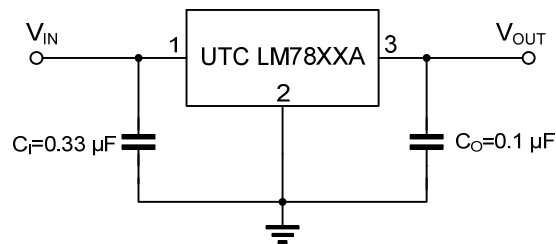

Note 1: To specify an output voltage, substitute voltage value for "XX".

2: Bypass capacitors are recommended for optimum stability and transient response and should be located as close as possible to the regulators.

■ ABSOLUTE MAXIMUM RATINGS (Operating temperature range applies unless otherwise specified)

PARAMETER		SYMBOL	RATING	UNIT
Input voltage	$V_{OUT}=5\sim 18V$	V_{IN}	35	V
	$V_{OUT}=24V$		40	V
Output Current		I_{OUT}	1.5	A
Power Dissipation		P_D	Internally Limited	W
Operating Junction Temperature		T_{OPR}	-20 ~ +125	°C
Storage Temperature		T_{STG}	-55 ~ +150	°C

Note: Absolute maximum ratings are those values beyond which the device could be permanently damaged. Absolute maximum ratings are stress ratings only and functional device operation is not implied.

■ THERMAL DATA

PARAMETER		SYMBOL	RATING	UNIT
Junction to Ambient		θ_{JA}	65	°C/W
Junction to Case	TO-220	θ_{JC}	5	°C/W
	TO-220F/TO-220F2		8	

■ ELECTRICAL CHARACTERISTICS

($I_{OUT}=0.5A$, $T_J=0^\circ C\sim 125^\circ C$, $C_i=0.33\mu F$, $C_o=0.1\mu F$, unless otherwise specified)(Note 1)

For UTC LM7805A ($V_{IN}=10V$)

PARAMETER	SYMBOL	TEST CONDITIONS	MIN	TYP	MAX	UNIT
Output Voltage	V_{OUT}	$T_J=25^\circ C$, $I_{OUT}=5mA \sim 1.0A$	4.80	5.0	5.20	V
		$V_{IN}=7.5V \sim 20V$, $I_{OUT}=5mA \sim 1.0A$, $P_D \leq 15W$	4.75		5.25	V
Dropout Voltage	V_D	$T_J=25^\circ C$		2.0		V
Load Regulation	ΔV_{OUT}	$T_J=25^\circ C$, $I_{OUT}=5mA \sim 1.5A$			100	mV
		$T_J=25^\circ C$, $I_{OUT}=0.25A \sim 0.75A$			50	mV
Line regulation	ΔV_{OUT}	$V_{IN}=7V \sim 25V$, $T_J=25^\circ C$			50	mV
		$V_{IN}=7.5V \sim 20V$, $T_J=25^\circ C$, $I_{OUT}=1.0A$			50	mV
Quiescent Current	I_Q	$T_J=25^\circ C$, $I_{OUT} \leq 1.0A$			8.0	mA
Quiescent Current Change	ΔI_Q	$V_{IN}=7.5V \sim 20V$			1.0	mA
		$I_{OUT}=5mA \sim 1.0A$			0.5	mA
Output Noise Voltage	eN	$10Hz \leq f \leq 100kHz$		40		μV
Temperature Coefficient of V_o	$\Delta V_o/\Delta T$	$I_{OUT}=5mA$		-0.6		mV/°C
Ripple Rejection	RR	$V_{IN}=8V \sim 18V$, $f=120Hz$, $T_J=25^\circ C$	62	80		dB
Peak Output Current	I_{PEAK}	$T_J=25^\circ C$		1.8		A

For UTC LM7806A ($V_{IN}=11V$)

PARAMETER	SYMBOL	TEST CONDITIONS	MIN	TYP	MAX	UNIT
Output Voltage	V_{OUT}	$T_J=25^\circ C$, $I_{OUT}=5mA \sim 1.0A$	5.76	6.0	6.24	V
		$V_{IN}=8.5V \sim 21V$, $I_{OUT}=5mA \sim 1.0A$, $P_D \leq 15W$	5.70		6.30	V
Dropout Voltage	V_D	$T_J=25^\circ C$		2.0		V
Load Regulation	ΔV_{OUT}	$T_J=25^\circ C$, $I_{OUT}=5mA \sim 1.5A$			100	mV
		$T_J=25^\circ C$, $I_{OUT}=0.25A \sim 0.75A$			50	mV
Line regulation	ΔV_{OUT}	$V_{IN}=8V \sim 25V$, $T_J=25^\circ C$			60	mV
		$V_{IN}=8.5V \sim 21V$, $T_J=25^\circ C$, $I_{OUT}=1.0A$			60	mV
Quiescent Current	I_Q	$T_J=25^\circ C$, $I_{OUT} \leq 1.0A$			8.0	mA
Quiescent Current Change	ΔI_Q	$V_{IN}=8.5V \sim 21V$			1.0	mA
		$I_{OUT}=5mA \sim 1.0A$			0.5	mA
Output Noise Voltage	eN	$10Hz \leq f \leq 100kHz$		45		μV
Temperature Coefficient of V_o	$\Delta V_o/\Delta T$	$I_{OUT}=5mA$		-0.7		mV/°C
Ripple Rejection	RR	$V_{IN}=9V \sim 19V$, $f=120Hz$, $T_J=25^\circ C$	59	75		dB
Peak Output Current	I_{PEAK}	$T_J=25^\circ C$		1.8		A

■ ELECTRICAL CHARACTERISTICS(Cont.)

For UTC LM7807A ($V_{IN} = 13V$)

PARAMETER	SYMBOL	TEST CONDITIONS	MIN	TYP	MAX	UNIT
Output Voltage	V_{OUT}	$T_J = 25^\circ C, I_{OUT} = 5mA - 1.0A$	6.72	7.0	7.28	V
		$V_{IN} = 9.5V \sim 22V,$ $I_{OUT} = 5mA \sim 1.0A, P_D \leq 15W$	6.65		7.35	V
Dropout Voltage	V_D	$T_J = 25^\circ C$		2.0		V
Load Regulation	ΔV_{OUT}	$T_J = 25^\circ C, I_{OUT} = 5mA \sim 1.5A$			100	mV
		$T_J = 25^\circ C, I_{OUT} = 0.25A \sim 0.75A$			50	mV
Line regulation	ΔV_{OUT}	$V_{IN} = 9V \sim 25V, T_J = 25^\circ C$			70	mV
		$V_{IN} = 9.5V \sim 22V, T_J = 25^\circ C, I_{OUT} = 1.0A$			70	mV
Quiescent Current	I_Q	$T_J = 25^\circ C, I_{OUT} \leq 1.0A$			8.0	mA
Quiescent Current Change	ΔI_Q	$V_{IN} = 9.5V \sim 22V$			1.0	mA
		$I_{OUT} = 5mA \sim 1.0A$			0.5	mA
Output Noise Voltage	eN	$10Hz \leq f \leq 100kHz$		50		μV
Temperature Coefficient of V_o	$\Delta V_o / \Delta T$	$I_{OUT} = 5mA$		-0.8		$mV/^\circ C$
Ripple Rejection	RR	$V_{IN} = 10V \sim 20V, f = 120Hz, T_J = 25^\circ C$	59	75		dB
Peak Output Current	I_{PEAK}	$T_J = 25^\circ C$		1.7		A

For UTC LM7808A ($V_{IN} = 14V$)

PARAMETER	SYMBOL	TEST CONDITIONS	MIN	TYP	MAX	UNIT
Output Voltage	V_{OUT}	$T_J = 25^\circ C, I_{OUT} = 5mA \sim 1.0A$	7.68	8.0	8.32	V
		$V_{IN} = 10.5V \sim 23V,$ $I_{OUT} = 5mA \sim 1.0A, P_D \leq 15W$	7.60		8.40	V
Dropout Voltage	V_D	$T_J = 25^\circ C$		2.0		V
Load Regulation	ΔV_{OUT}	$T_J = 25^\circ C, I_{OUT} = 5mA \sim 1.5A$			100	mV
		$T_J = 25^\circ C, I_{OUT} = 0.25A \sim 0.75A$			50	mV
Line regulation	ΔV_{OUT}	$V_{IN} = 10.5V \sim 25V, T_J = 25^\circ C$			80	mV
		$V_{IN} = 10.5V \sim 23V, T_J = 25^\circ C, I_{OUT} = 1.0A$			80	mV
Quiescent Current	I_Q	$T_J = 25^\circ C, I_{OUT} \leq 1.0A$			8.0	mA
Quiescent Current Change	ΔI_Q	$V_{IN} = 10.5V \sim 23V$			1.0	mA
		$I_{OUT} = 5mA \sim 1.0A$			0.5	mA
Output Noise Voltage	eN	$10Hz \leq f \leq 100kHz$		58		μV
Temperature Coefficient of V_o	$\Delta V_o / \Delta T$	$I_{OUT} = 5mA$		-0.9		$mV/^\circ C$
Ripple Rejection	RR	$V_{IN} = 11.5V \sim 21.5V,$ $f = 120Hz, T_J = 25^\circ C$	56	72		dB
Peak Output Current	I_{PEAK}	$T_J = 25^\circ C$		1.8		A

■ ELECTRICAL CHARACTERISTICS(Cont.)

For UTC LM7809A ($V_{IN} = 15V$)

PARAMETER	SYMBOL	TEST CONDITIONS	MIN	TYP	MAX	UNIT
Output Voltage	V_{OUT}	$T_J = 25^\circ C, I_{OUT} = 5mA \sim 1.0A$	8.64	9.0	9.36	V
		$V_{IN} = 11.5V \sim 24V,$ $I_{OUT} = 5mA \sim 1.0A, P_D \leq 15W$	8.55		9.45	V
Dropout Voltage	V_D	$T_J = 25^\circ C$		2.0		V
Load Regulation	ΔV_{OUT}	$T_J = 25^\circ C, I_{OUT} = 5mA \sim 1.5A$			100	mV
		$T_J = 25^\circ C, I_{OUT} = 0.25A \sim 0.75A$			50	mV
Line regulation	ΔV_{OUT}	$V_{IN} = 11.5V \sim 25V, T_J = 25^\circ C$			90	mV
		$V_{IN} = 11.5V \sim 24V, T_J = 25^\circ C, I_{OUT} = 1.0A$			90	mV
Quiescent Current	I_Q	$T_J = 25^\circ C, I_{OUT} \leq 1.0A$			8.0	mA
Quiescent Current Change	ΔI_Q	$V_{IN} = 11.5V \sim 24V$			1.0	mA
		$I_{OUT} = 5mA \sim 1.0A$			0.5	mA
Output Noise Voltage	eN	$10Hz \leq f \leq 100kHz$		58		μV
Temperature Coefficient of V_o	$\Delta V_o / \Delta T$	$I_{OUT} = 5mA$		-1.1		$mV/^\circ C$
Ripple Rejection	RR	$V_{IN} = 12.5V \sim 22.5V, f = 120Hz, T_J = 25^\circ C$	56	72		dB
Peak Output Current	I_{PEAK}	$T_J = 25^\circ C$		1.8		A

For UTC LM7810A ($V_{IN} = 16V$)

PARAMETER	SYMBOL	TEST CONDITIONS	MIN	TYP	MAX	UNIT
Output Voltage	V_{OUT}	$T_J = 25^\circ C, I_{OUT} = 5mA \sim 1.0A$	9.60	10.0	10.40	V
		$V_{IN} = 12.5V \sim 25V,$ $I_{OUT} = 5mA \sim 1.0A, P_D \leq 15W$	9.50		10.50	V
Dropout Voltage	V_D	$T_J = 25^\circ C$		2.0		V
Load Regulation	ΔV_{OUT}	$T_J = 25^\circ C, I_{OUT} = 5mA \sim 1.5A$			100	mV
		$T_J = 25^\circ C, I_{OUT} = 0.25A \sim 0.75A$			50	mV
Line regulation	ΔV_{OUT}	$V_{IN} = 13V \sim 25V, T_J = 25^\circ C$			100	mV
		$V_{IN} = 13V \sim 25V, T_J = 25^\circ C, I_{OUT} = 1.0A$			100	mV
Quiescent Current	I_Q	$T_J = 25^\circ C, I_{OUT} \leq 1.0A$			8.0	mA
Quiescent Current Change	ΔI_Q	$V_{IN} = 12.6V \sim 25V$			1.0	mA
		$I_{OUT} = 5mA \sim 1.0A$			0.5	mA
Output Noise Voltage	eN	$10Hz \leq f \leq 100kHz$		58		μV
Temperature coefficient of V_o	$\Delta V_o / \Delta T$	$I_{OUT} = 5mA$		-1.1		$mV/^\circ C$
Ripple Rejection	RR	$V_{IN} = 13V \sim 23V, f = 120Hz, T_J = 25^\circ C$	56	72		dB
Peak Output Current	I_{PEAK}	$T_J = 25^\circ C$		1.8		A

■ ELECTRICAL CHARACTERISTICS(Cont.)

For UTC LM7812A ($V_{IN} = 19V$)

PARAMETER	SYMBOL	TEST CONDITIONS	MIN	TYP	MAX	UNIT
Output Voltage	V_{OUT}	$T_J = 25^\circ C, I_{OUT} = 5mA \sim 1.0A$	11.52	12.0	12.48	V
		$V_{IN} = 14.5V \sim 27V, I_{OUT} = 5mA \sim 1.0A, P_D \leq 15W$	11.40		12.60	V
Dropout Voltage	V_D	$T_J = 25^\circ C$		2.0		V
Load Regulation	ΔV_{OUT}	$T_J = 25^\circ C, I_{OUT} = 5mA \sim 1.5A$			100	mV
		$T_J = 25^\circ C, I_{OUT} = 0.25A \sim 0.75A$			50	mV
Line regulation	ΔV_{OUT}	$V_{IN} = 14.5V \sim 30V, T_J = 25^\circ C$			120	mV
		$V_{IN} = 14.6V \sim 27V, T_J = 25^\circ C, I_{OUT} = 1.0A$			120	mV
Quiescent Current	I_Q	$T_J = 25^\circ C, I_{OUT} \leq 1.0A$			8.0	mA
Quiescent Current Change	ΔI_Q	$V_{IN} = 14.5V \sim 30V$			1.0	mA
		$I_{OUT} = 5mA \sim 1.0A$			0.5	mA
Output Noise Voltage	eN	$10Hz \leq f \leq 100kHz$		75		μV
Temperature Coefficient of V_o	$\Delta V_o / \Delta T$	$I_{OUT} = 5mA$		-1.5		$mV/^\circ C$
Ripple Rejection	RR	$V_{IN} = 15V - 25V, f = 120Hz, T_J = 25^\circ C$	55	72		dB
Peak Output Current	I_{PEAK}	$T_J = 25^\circ C$		1.8		A

For UTC LM7815A ($V_{IN} = 23V$)

PARAMETER	SYMBOL	TEST CONDITIONS	MIN	TYP	MAX	UNIT
Output Voltage	V_{OUT}	$T_J = 25^\circ C, I_{OUT} = 5mA \sim 1.0A$	14.40	15.0	15.60	V
		$V_{IN} = 17.5V \sim 30V, I_{OUT} = 5mA \sim 1.0A, P_D \leq 15W$	14.25		15.75	V
Dropout Voltage	V_D	$T_J = 25^\circ C$		2.0		V
Load Regulation	ΔV_{OUT}	$T_J = 25^\circ C, I_{OUT} = 5mA \sim 1.5A$			100	mV
		$T_J = 25^\circ C, I_{OUT} = 0.25A \sim 0.75A$			50	mV
Line regulation	ΔV_{OUT}	$V_{IN} = 18.5V \sim 30V, T_J = 25^\circ C$			150	mV
		$V_{IN} = 17.7V \sim 30V, T_J = 25^\circ C, I_{OUT} = 1.0A$			150	mV
Quiescent Current	I_Q	$T_J = 25^\circ C, I_{OUT} \leq 1.0A$			8.0	mA
Quiescent Current Change	ΔI_Q	$V_{IN} = 17.5V \sim 30V$			1.0	mA
		$I_{OUT} = 5mA \sim 1.0A$			0.5	mA
Output Noise Voltage	eN	$10Hz \leq f \leq 100kHz$		90		μV
Temperature Coefficient of V_o	$\Delta V_o / \Delta T$	$I_{OUT} = 5mA$		-1.8		$mV/^\circ C$
Ripple Rejection	RR	$V_{IN} = 18.5V \sim 28.5V, f = 120Hz, T_J = 25^\circ C$	54	70		dB
Peak Output Current	I_{PEAK}	$T_J = 25^\circ C$		1.8		A

■ ELECTRICAL CHARACTERISTICS(Cont.)

For UTC LM7818A ($V_{IN} = 27V$)

PARAMETER	SYMBOL	TEST CONDITIONS	MIN	TYP	MAX	UNIT
Output Voltage	V_{OUT}	$T_J = 25^\circ C, I_{OUT} = 5mA \sim 1.0A$	17.28	18.0	18.72	V
		$V_{IN} = 21V \sim 33V, I_{OUT} = 5mA \sim 1.0A, P_D \leq 15W$	17.10		18.90	V
Dropout Voltage	V_D	$T_J = 25^\circ C$		2.0		V
Load Regulation	ΔV_{OUT}	$T_J = 25^\circ C, I_{OUT} = 5mA \sim 1.5A$			100	mV
		$T_J = 25^\circ C, I_{OUT} = 0.25A \sim 0.75A$			50	mV
Line regulation	ΔV_{OUT}	$V_{IN} = 21V \sim 33V, T_J = 25^\circ C$			180	mV
		$V_{IN} = 21V \sim 33V, T_J = 25^\circ C, I_{OUT} = 1.0A$			180	mV
Quiescent Current	I_Q	$T_J = 25^\circ C, I_{OUT} \leq 1.0A$			8.0	mA
Quiescent Current Change	ΔI_Q	$V_{IN} = 21.5V \sim 33V$			1.0	mA
		$I_{OUT} = 5mA \sim 1.0A$			0.5	mA
Output Noise Voltage	eN	$10Hz \leq f \leq 100kHz$		110		μV
Temperature Coefficient of V_o	$\Delta V_o / \Delta T$	$I_{OUT} = 5mA$		-2.2		$mV/^\circ C$
Ripple Rejection	RR	$V_{IN} = 22V \sim 32V, f = 120Hz, T_J = 25^\circ C$	53	69		dB
Peak Output Current	I_{PEAK}	$T_J = 25^\circ C$		1.8		A

For UTC LM7824A ($V_{IN} = 33V$)

PARAMETER	SYMBOL	TEST CONDITIONS	MIN	TYP	MAX	UNIT
Output Voltage	V_{OUT}	$T_J = 25^\circ C, I_{OUT} = 5mA \sim 1.0A$	23.04	24.0	24.96	V
		$V_{IN} = 27V \sim 38V, I_{OUT} = 5mA \sim 1.0A, P_D \leq 15W$	22.80		25.20	V
Dropout Voltage	V_D	$T_J = 25^\circ C$		2.0		V
Load Regulation	ΔV_{OUT}	$T_J = 25^\circ C, I_{OUT} = 5mA \sim 1.5A$			100	mV
		$T_J = 25^\circ C, I_{OUT} = 0.25A \sim 0.75A$			50	mV
Line regulation	ΔV_{OUT}	$V_{IN} = 27V \sim 38V, T_J = 25^\circ C$			240	mV
		$V_{IN} = 27V \sim 38V, T_J = 25^\circ C, I_{OUT} = 1.0A$			240	mV
Quiescent Current	I_Q	$T_J = 25^\circ C, I_{OUT} \leq 1.0A$			8.0	mA
Quiescent Current Change	ΔI_Q	$V_{IN} = 28V \sim 38V$			1.0	mA
		$I_{OUT} = 5mA \sim 1.0A$			0.5	mA
Output Noise Voltage	eN	$10Hz \leq f \leq 100kHz$		170		μV
Temperature Coefficient of V_o	$\Delta V_o / \Delta T$	$I_{OUT} = 5mA$		-2.8		$mV/^\circ C$
Ripple Rejection	RR	$V_{IN} = 28V \sim 38V, f = 120Hz, T_J = 25^\circ C$	50	66		dB
Peak Output Current	I_{PEAK}	$T_J = 25^\circ C$		1.8		A

Note 1: The Maximum steady state usable output current are dependent on input voltage, heat sinking, lead length of the package and copper pattern of PCB. The data above represents pulse test conditions with junction temperatures specified at the initiation of test.

2. Power dissipation < 0.5W.

TYPICAL CHARACTERISTICS

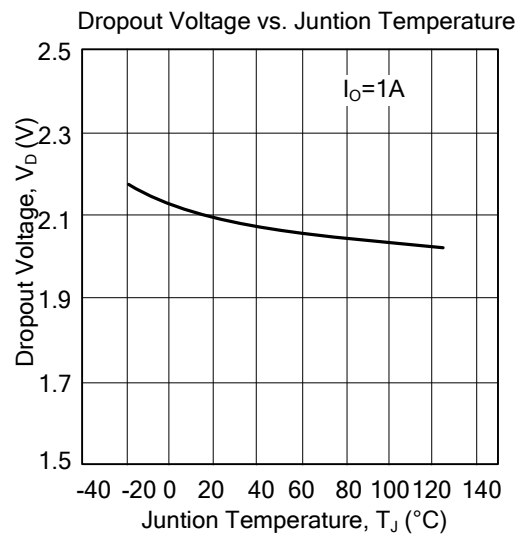
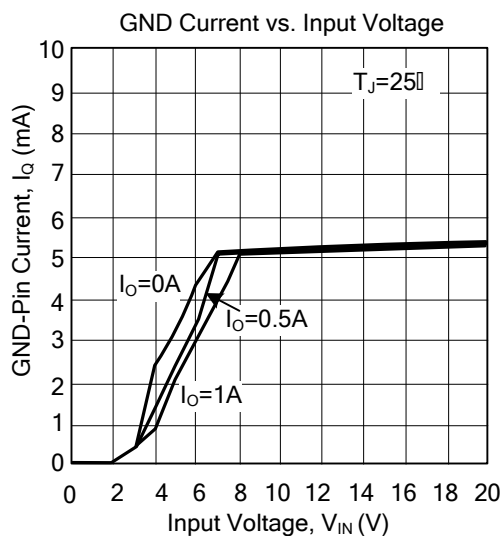
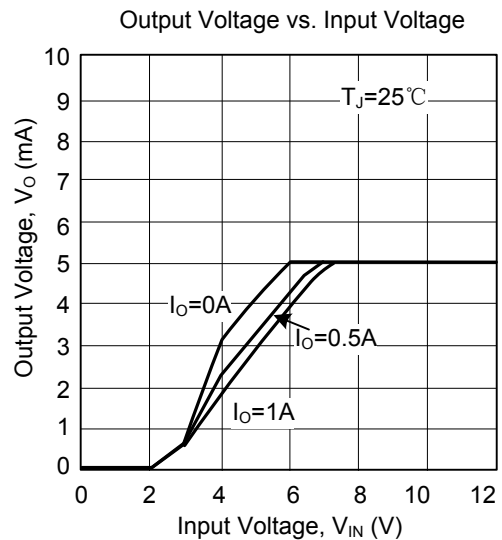
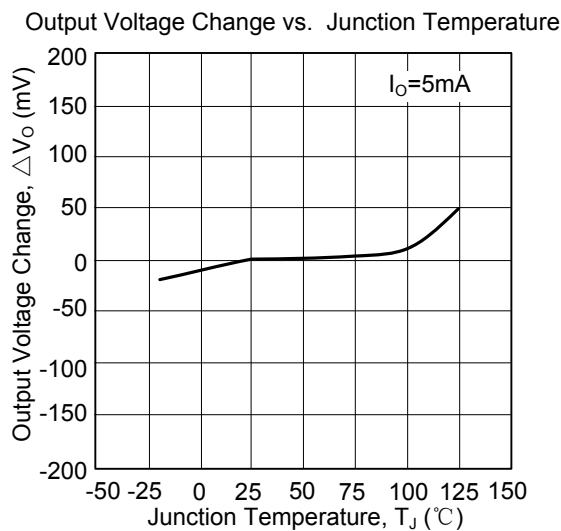
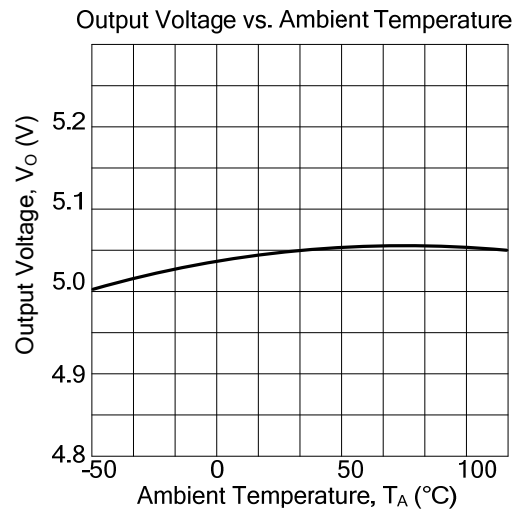
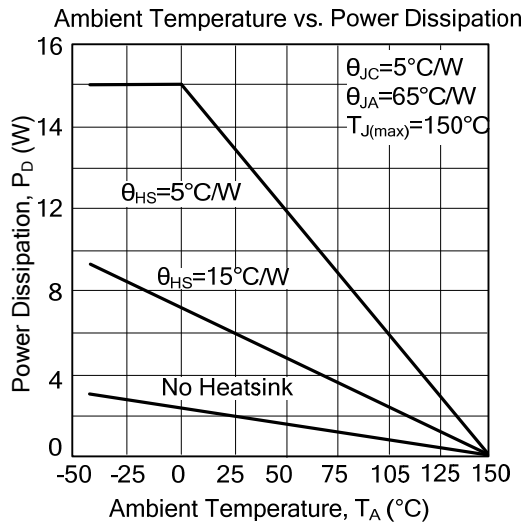

■ TYPICAL CHARACTERISTICS(Cont.)

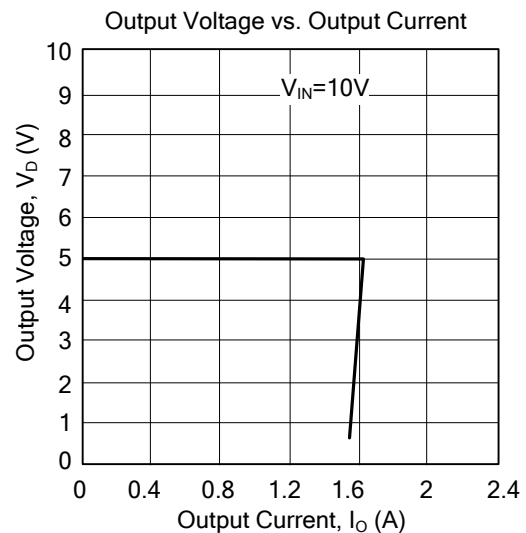
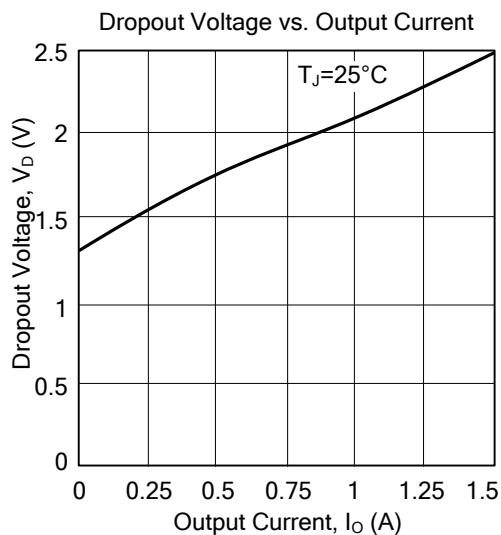
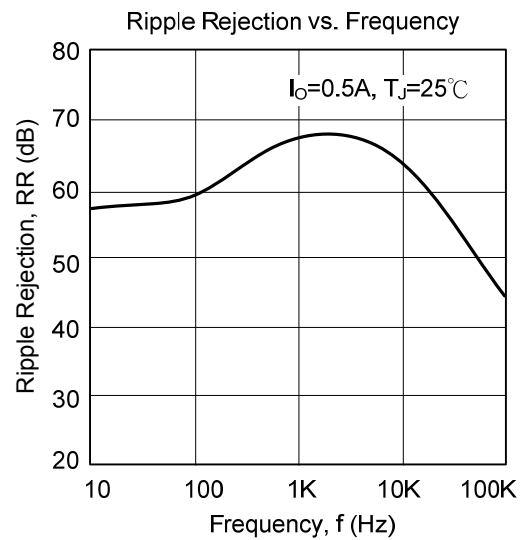
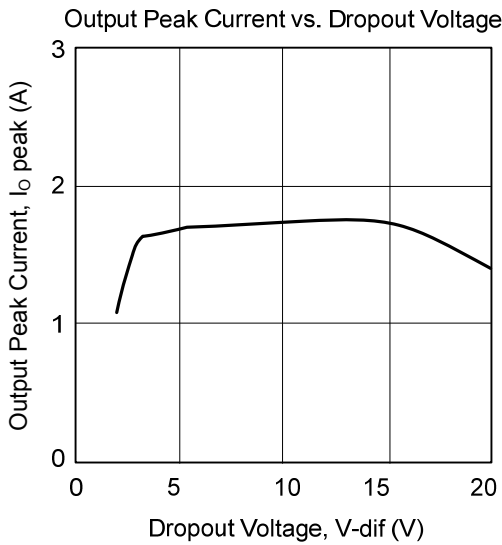

UTC assumes no responsibility for equipment failures that result from using products at values that exceed, even momentarily, rated values (such as maximum ratings, operating condition ranges, or other parameters) listed in products specifications of any and all UTC products described or contained herein. UTC products are not designed for use in life support appliances, devices or systems where malfunction of these products can be reasonably expected to result in personal injury. Reproduction in whole or in part is prohibited without the prior written consent of the copyright owner. The information presented in this document does not form part of any quotation or contract, is believed to be accurate and reliable and may be changed without notice.

X-ON Electronics

Largest Supplier of Electrical and Electronic Components

Click to view similar products for [Linear Voltage Regulators](#) category:

Click to view products by [Unisonic](#) manufacturer:

Other Similar products are found below :

[LV56831P-E](#) [LV5684PVD-XH](#) [MCDTSA6-2R](#) [L4953G](#) [L7815ACV-DG](#) [PQ3DZ53U](#) [LV56801P-E](#) [TCR3DF13,LM\(CT](#)
[TCR3DF39,LM\(CT](#) [TLE42794G](#) [L78L05CZ/1SX](#) [L78LR05DL-MA-E](#) [L78MR05-E](#) [033150D](#) [033151B](#) [090756R](#) [636416C](#)
[NCV78M15BDTG](#) [702482B](#) [714954EB](#) [TLE42794GM](#) [TLE42994GM](#) [ZMR500QFTA](#) [BA033LBSG2-TR](#) [NCV78M05ABDTRKG](#)
[NCV78M08BDTRKG](#) [NCP7808TG](#) [NCV571SN12T1G](#) [LV5680P-E](#) [CAJ24C256YI-GT3](#) [L78M15CV-DG](#) [L9474N](#)
[TLS202B1MBV33HTSA1](#) [L79M05T-E](#) [NCP571SN09T1G](#) [MAX15006AASA/V+](#) [MIC5283-5.0YML-T5](#) [L4969URTR-E](#) [L78LR05D-MA-E](#)
[NCV7808BDTRKG](#) [L9466N](#) [NCP7805ETG](#) [SC7812CTG](#) [NCV7809BTG](#) [NCV571SN09T1G](#) [NCV317MBTG](#) [MC78M15CDTT5G](#)
[MC78M12CDTT5G](#) [L9468N](#) [LT1054IS8#TRPBF](#)