

UTC LM79XX LINEAR INTEGRATED CIRCUIT

ABSOLUTE MAXIMUM RATINGS(Ta=25°C)

PARAMETER	SYMBOL	VALUE	UNIT
Input voltage	V_i	-35	V
Thermal resistance junction-air	$R_{\theta JA}$	65	°C/W
Thermal resistance junction-cases	$R_{\theta JC}$	5	°C/W
Operating Temperature	T_{opr}	0 ~ +125	°C
Storage Temperature	T_{stg}	-65 ~ +150	°C

UTC7905 ELECTRICAL CHARACTERISTICS

(Refer to test circuits, $0 < T_j < 125^\circ\text{C}$, $I_o = 500\text{mA}$, $V_i = -10\text{V}$, $C_i = 33\mu\text{F}$, $C_o = 1\mu\text{F}$, unless otherwise specified)

PARAMETER	SYMBOL	TEST CONDITIONS	MIN	TYP	MAX	UNIT
Output voltage	V_o	$T_j = 25^\circ\text{C}$	-4.80	-5.0	-5.20	V
		$5.0\text{mA} < I_o < 1.0\text{A}$, $P_o < 15\text{W}$ $V_i = -7\text{V}$ to -20V	-4.75		-5.25	V
Line regulation	ΔV_o	$T_j = 25^\circ\text{C}$, $V_i = -7\text{V}$ to -25V		10	100	mV
		$T_j = 25^\circ\text{C}$, $V_i = -8\text{V}$ to -12V				mV
Load regulation	ΔV_o	$T_j = 25^\circ\text{C}$, $I_o = 5.0\text{mA}$ to 1.5A		10	100	mV
		$T_j = 25^\circ\text{C}$, $I_o = 250\text{mA}$ to 750mA		3	50	mV
Quiescent current	I_q	$T_j = 25^\circ\text{C}$		3	6	mA
Quiescent current change	ΔI_q	$I_o = 5\text{mA}$ to 1.0A		0.05	0.5	mA
		$V_i = -7\text{V}$ to -25V		0.1	1.3	mA
Output voltage drift	$\Delta V_o / \Delta T$	$I_o = 5\text{mA}$		-0.4		mV/°C
Output noise voltage	V_N	$f = 10\text{Hz}$ to 100kHz , $T_a = 25^\circ\text{C}$		100		μV
Ripple rejection	RR	$f = 120\text{Hz}$, $V_i = -8\text{V}$ to -18V	54	60		dB
Dropout voltage	V_o	$I_o = 1.0\text{A}$, $T_j = 25^\circ\text{C}$		2		V
Short circuit current	I_{sc}	$V_i = -35\text{V}$, $T_a = 25^\circ\text{C}$		300		mA
peak current	I_{pk}	$T_j = 25^\circ\text{C}$		2.2		A

UTC7906 ELECTRICAL CHARACTERISTICS

(Refer to test circuits, $0 < T_j < 125^\circ\text{C}$, $I_o = 500\text{mA}$, $V_i = -11\text{V}$, $C_i = 2.2\mu\text{F}$, $C_o = 1\mu\text{F}$, unless otherwise specified)

PARAMETER	SYMBOL	TEST CONDITIONS	MIN	TYP	MAX	UNIT
Output voltage	V_o	$T_j = 25^\circ\text{C}$	-5.76	-6.00	-6.24	V
		$5.0\text{mA} < I_o < 1.0\text{A}$, $P_o < 15\text{W}$ $V_i = -8\text{V}$ to -21V	-5.70		-6.30	V
Line regulation	ΔV_o	$T_j = 25^\circ\text{C}$, $V_i = -8\text{V}$ to -25V		10	120	mV
		$T_j = 25^\circ\text{C}$, $V_i = -9\text{V}$ to -13V		5	60	mV
Load regulation	ΔV_o	$T_j = 25^\circ\text{C}$, $I_o = 5.0\text{mA}$ to 1.5A		10	120	mV
		$T_j = 25^\circ\text{C}$, $I_o = 250\text{mA}$ to 750mA		3	60	mV
Quiescent current	I_q	$T_j = 25^\circ\text{C}$		3	6	mA
Quiescent current change	ΔI_q	$I_o = 5\text{mA}$ to 1.0A			0.5	mA
		$V_i = -8\text{V}$ to -25V			1.3	mA
Output voltage drift	$\Delta V_o / \Delta T$	$I_o = 5\text{mA}$		-0.5		mV/°C
Output noise voltage	V_N	$f = 10\text{Hz}$ to 100kHz , $T_a = 25^\circ\text{C}$		130		μV
Ripple rejection	RR	$f = 120\text{Hz}$, $V_i = -9\text{V}$ to -19V	54	60		dB
Dropout voltage	V_o	$I_o = 1.0\text{A}$, $T_j = 25^\circ\text{C}$		2		V
Short circuit current	I_{sc}	$V_i = -35\text{V}$, $T_a = 25^\circ\text{C}$		300		mA
peak current	I_{pk}	$T_j = 25^\circ\text{C}$		2.2		A

UTC LM79XX LINEAR INTEGRATED CIRCUIT

UTC7908 ELECTRICAL CHARACTERISTICS

(Refer to test circuits, $0 < T_j < 125^\circ\text{C}$, $I_o = 500\text{mA}$, $V_i = -14\text{V}$, $C_i = 2.2\mu\text{F}$, $C_o = 1\mu\text{F}$, unless otherwise specified)

PARAMETER	SYMBOL	TEST CONDITIONS	MIN	TYP	MAX	UNIT
Output voltage	V_o	$T_j = 25^\circ\text{C}$	-7.68	-8.0	-8.32	V
		$5.0\text{mA} < I_o < 1.0\text{A}$, $P_o < 15\text{W}$ $V_i = -10.5\text{V}$ to -23V	-7.60		-8.40	V
Line regulation	ΔV_o	$T_j = 25^\circ\text{C}$, $V_i = -10.5\text{V}$ to -25V		10	100	mV
		$T_j = 25^\circ\text{C}$, $V_i = -11.5\text{V}$ to -17V		5	80	mV
Load regulation	ΔV_o	$T_j = 25^\circ\text{C}$, $I_o = 5.0\text{mA}$ to 1.5A		12	160	mV
		$T_j = 25^\circ\text{C}$, $I_o = 250\text{mA}$ to 750mA		4	80	mV
Quiescent current	I_Q	$T_j = 25^\circ\text{C}$		3	6	mA
Quiescent current change	ΔI_Q	$I_o = 5\text{mA}$ to 1.0A		0.05	0.5	mA
		$V_i = -11.5\text{V}$ to -25V		0.1	1.0	mA
Output voltage drift	$\Delta V_o / \Delta T$	$I_o = 5\text{mA}$		-0.6		mV/ $^\circ\text{C}$
Output noise voltage	V_N	$f = 10\text{Hz}$ to 100kHz , $T_a = 25^\circ\text{C}$		175		μV
Ripple rejection	RR	$f = 120\text{Hz}$, $V_i = -11.5\text{V}$ to -21.5V	54	60		dB
Dropout voltage	V_o	$I_o = 1.0\text{A}$, $T_j = 25^\circ\text{C}$		2		V
Short circuit current	I_{sc}	$V_i = -35\text{V}$, $T_a = 25^\circ\text{C}$		300		mA
peak current	I_{pk}	$T_j = 25^\circ\text{C}$		2.2		A

UTC7912 ELECTRICAL CHARACTERISTICS

(Refer to test circuits, $0 < T_j < 125^\circ\text{C}$, $I_o = 500\text{mA}$, $V_i = -18\text{V}$, $C_i = 2.2\mu\text{F}$, $C_o = 1\mu\text{F}$, unless otherwise specified)

PARAMETER	SYMBOL	TEST CONDITIONS	MIN	TYP	MAX	UNIT
Output voltage	V_o	$T_j = 25^\circ\text{C}$	-11.52	-12.0	-12.48	V
		$5.0\text{mA} < I_o < 1.0\text{A}$, $P_o < 15\text{W}$ $V_i = -14.5\text{V}$ to -27V	-11.40		-12.60	V
Line regulation	ΔV_o	$T_j = 25^\circ\text{C}$, $V_i = -14.5\text{V}$ to -30V		12	240	mV
		$T_j = 25^\circ\text{C}$, $V_i = -16\text{V}$ to -22V		6	120	mV
Load regulation	ΔV_o	$T_j = 25^\circ\text{C}$, $I_o = 5.0\text{mA}$ to 1.5A		12	240	mV
		$T_j = 25^\circ\text{C}$, $I_o = 250\text{mA}$ to 750mA		4	120	mV
Quiescent current	I_Q	$T_j = 25^\circ\text{C}$		3	6	mA
Quiescent current change	ΔI_Q	$I_o = 5\text{mA}$ to 1.0A		0.05	0.5	mA
		$V_i = -14.5\text{V}$ to -30V		0.1	1.0	mA
Output voltage drift	$\Delta V_o / \Delta T$	$I_o = 5\text{mA}$		-0.8		mV/ $^\circ\text{C}$
Output noise voltage	V_N	$f = 10\text{Hz}$ to 100kHz , $T_a = 25^\circ\text{C}$		200		μV
Ripple rejection	RR	$f = 120\text{Hz}$, $V_i = -15\text{V}$ to -25V	54	60		dB
Dropout voltage	V_o	$I_o = 1.0\text{A}$, $T_j = 25^\circ\text{C}$		2		V
Short circuit current	I_{sc}	$V_i = -35\text{V}$, $T_a = 25^\circ\text{C}$		300		mA
peak current	I_{pk}	$T_j = 25^\circ\text{C}$		2.2		A

UTC LM79XX LINEAR INTEGRATED CIRCUIT

UTC7915 ELECTRICAL CHARACTERISTICS

(Refer to test circuits, $0 < T_j < 125^\circ\text{C}$, $I_o = 500\text{mA}$, $V_i = -23\text{V}$, $C_i = 2.2\mu\text{F}$, $C_o = 1\mu\text{F}$, unless otherwise specified)

PARAMETER	SYMBOL	TEST CONDITIONS	MIN	TYP	MAX	UNIT
Output voltage	V_o	$T_j = 25^\circ\text{C}$	-14.40	-15.0	-15.60	V
		$5.0\text{mA} < I_o < 1.0\text{A}$, $P_o < 15\text{W}$ $V_i = -17.5\text{V}$ to -30V	-14.25		-15.75	V
Line regulation	ΔV_o	$T_j = 25^\circ\text{C}$, $V_i = -17.5\text{V}$ to -30V		12	300	mV
		$T_j = 25^\circ\text{C}$, $V_i = -20\text{V}$ to -26V		6	150	mV
Load regulation	ΔV_o	$T_j = 25^\circ\text{C}$, $I_o = 5.0\text{mA}$ to 1.5A		12	300	mV
		$T_j = 25^\circ\text{C}$, $I_o = 250\text{mA}$ to 750mA		4	150	mV
Quiescent current	I_Q	$T_j = 25^\circ\text{C}$		3	6	mA
Quiescent current change	ΔI_Q	$I_o = 5\text{mA}$ to 1.0A		0.05	0.5	mA
		$V_i = -17.5\text{V}$ to -30.5V		0.1	1.0	mA
Output voltage drift	$\Delta V_o / \Delta T$	$I_o = 5\text{mA}$		-0.9		mV/ $^\circ\text{C}$
Output noise voltage	V_N	$f = 10\text{Hz}$ to 100kHz , $T_a = 25^\circ\text{C}$		250		μV
Ripple rejection	RR	$f = 120\text{Hz}$, $V_i = -18.5\text{V}$ to -28.5V	54	60		dB
Dropout voltage	V_o	$I_o = 1.0\text{A}$, $T_j = 25^\circ\text{C}$		2		V
Short circuit current	I_{sc}	$V_i = -35\text{V}$, $T_a = 25^\circ\text{C}$		300		mA
peak current	I_{pk}	$T_j = 25^\circ\text{C}$		2.2		A

UTC7918 ELECTRICAL CHARACTERISTICS

(Refer to test circuits, $0 < T_j < 125^\circ\text{C}$, $I_o = 500\text{mA}$, $V_i = -27\text{V}$, $C_i = 2.2\mu\text{F}$, $C_o = 1\mu\text{F}$, unless otherwise specified)

PARAMETER	SYMBOL	TEST CONDITIONS	MIN	TYP	MAX	UNIT
Output voltage	V_o	$T_j = 25^\circ\text{C}$	-17.28	-18.0	-18.72	V
		$5.0\text{mA} < I_o < 1.0\text{A}$, $P_o < 15\text{W}$ $V_i = -21\text{V}$ to -33V	-17.10		-18.90	V
Line regulation	ΔV_o	$T_j = 25^\circ\text{C}$, $V_i = -21\text{V}$ to -33V		15	360	mV
		$T_j = 25^\circ\text{C}$, $V_i = -24\text{V}$ to -30V		8	180	mV
Load regulation	ΔV_o	$T_j = 25^\circ\text{C}$, $I_o = 5.0\text{mA}$ to 1.5A		15	360	mV
		$T_j = 25^\circ\text{C}$, $I_o = 250\text{mA}$ to 750mA		5.0	180	mV
Quiescent current	I_Q	$T_j = 25^\circ\text{C}$		3	6	mA
Quiescent current change	ΔI_Q	$I_o = 5\text{mA}$ to 1.0A			0.5	mA
		$V_i = -21\text{V}$ to -32V			1.0	mA
Output voltage drift	$\Delta V_o / \Delta T$	$I_o = 5\text{mA}$		-1		mV/ $^\circ\text{C}$
Output noise voltage	V_N	$f = 10\text{Hz}$ to 100kHz , $T_a = 25^\circ\text{C}$		300		μV
Ripple rejection	RR	$f = 120\text{Hz}$, $V_i = -22\text{V}$ to -32V	54	60		dB
Dropout voltage	V_o	$I_o = 1.0\text{A}$, $T_j = 25^\circ\text{C}$		2		V
Short circuit current	I_{sc}	$V_i = -35\text{V}$, $T_a = 25^\circ\text{C}$		300		mA
peak current	I_{pk}	$T_j = 25^\circ\text{C}$		2.2		A

UTC LM79XX LINEAR INTEGRATED CIRCUIT

UTC7924 ELECTRICAL CHARACTERISTICS

(Refer to test circuits, $0 < T_j < 125^\circ\text{C}$, $I_o = 500\text{mA}$, $V_i = -33\text{V}$, $C_i = 2.2\mu\text{F}$, $C_o = 1\mu\text{F}$, unless otherwise specified)

PARAMETER	SYMBOL	TEST CONDITIONS	MIN	TYP	MAX	UNIT
Output voltage	V_o	$T_j = 25^\circ\text{C}$	-23.04	-24	-24.96	V
		$5.0\text{mA} < I_o < 1.0\text{A}$, $P_o < 15\text{W}$ $V_i = -27\text{V}$ to -38V	-22.80		-25.20	V
Line regulation	ΔV_o	$T_j = 25^\circ\text{C}$, $V_i = -27\text{V}$ to -38V		15	480	mV
		$T_j = 25^\circ\text{C}$, $V_i = -30\text{V}$ to -36V		8	240	mV
Load regulation	ΔV_o	$T_j = 25^\circ\text{C}$, $I_o = 5.0\text{mA}$ to 1.5A		15	480	mV
		$T_j = 25^\circ\text{C}$, $I_o = 250\text{mA}$ to 750mA		5.0	240	mV
Quiescent current	I_Q	$T_j = 25^\circ\text{C}$		3	6	mA
Quiescent current change	ΔI_Q	$I_o = 5\text{mA}$ to 1.0A			0.5	mA
		$V_i = -27\text{V}$ to -38V			1.0	mA
Output voltage drift	$\Delta V_o / \Delta T$	$I_o = 5\text{mA}$		-1		mV/ $^\circ\text{C}$
Output noise voltage	V_N	$f = 10\text{Hz}$ to 100kHz , $T_a = 25^\circ\text{C}$		400		μV
Ripple rejection	RR	$f = 120\text{Hz}$, $V_i = -28\text{V}$ to -38V	54	60		dB
Dropout voltage	V_o	$I_o = 1.0\text{A}$, $T_j = 25^\circ\text{C}$		2		V
Short circuit current	I_{sc}	$V_i = -35\text{V}$, $T_a = 25^\circ\text{C}$		300		mA
peak current	I_{pk}	$T_j = 25^\circ\text{C}$		2.2		A

APPLICATION CIRCUITS

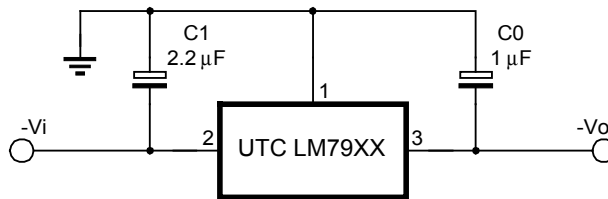

Fig.1 Fixed output regulator

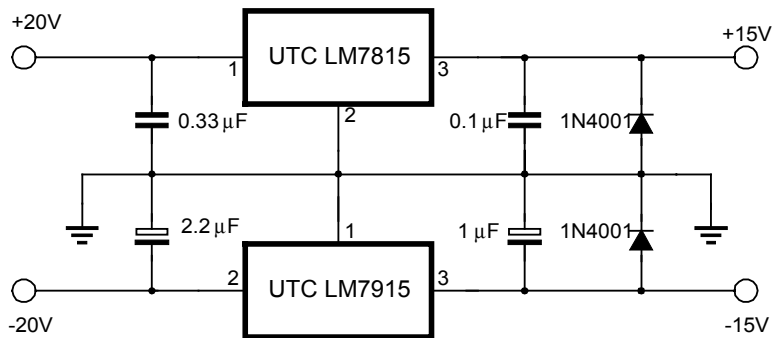

Fig.2 Split power supply(+15V, 1A)

UTC LM79XX LINEAR INTEGRATED CIRCUIT

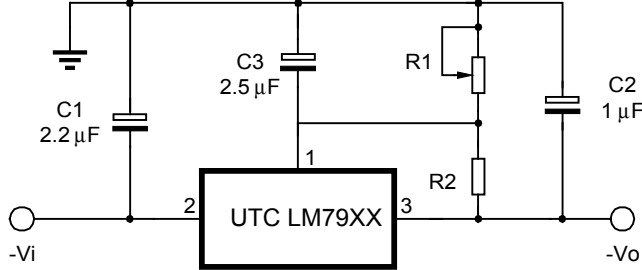

Fig.3 Circuit for increasing output voltage

X-ON Electronics

Largest Supplier of Electrical and Electronic Components

Click to view similar products for [Linear Voltage Regulators](#) category:

Click to view products by [Unisonic](#) manufacturer:

Other Similar products are found below :

[LV5684PVD-XH](#) [MCDTSA6-2R](#) [L7815ACV-DG](#) [LV56801P-E](#) [UA7805CKC](#) [714954EB](#) [ZMR500QFTA](#) [BA033LBSG2-TR](#)

[NCV78M05ABDTRKG](#) [LV5680P-E](#) [L79M05T-E](#) [L78LR05D-MA-E](#) [NCV317MBTG](#) [NTE7227](#) [MP2018GZD-33-P](#) [MP2018GZD-5-P](#)

[LV5680NPVC-XH](#) [ZTS6538SE](#) [UA78L09CLP](#) [UA78L09CLPR](#) [CAT6221-PPTD-GT3](#) [MC78M09CDTRK](#) [NCV51190MNTAG](#)

[BL1118CS8TR1833](#) [BL8563CKETR18](#) [BL8077CKETR33](#) [BL9153-33CC3TR](#) [BL9161G-15BADRN](#) [BL9161G-28BADRN](#)

[BRCO7530MMC](#) [CJ7815B-TFN-ARG](#) [LM317C](#) [GM7333K](#) [GM7350K](#) [XC6206P332MR](#) [HT7533](#) [LM7912S/TR](#) [LT1764S/TR](#) [LM7805T](#)

[LM338T](#) [LM1117IMP-3.3/TR](#) [HT1117AM-3.3](#) [HT7550S](#) [AMS1117-3.3](#) [HT7150S](#) [78L12](#) [HT7550](#) [HT7533-1](#) [HXY6206I-2.5](#) [HT7133](#)