



LMV393

Preliminary

LINEAR INTEGRATED CIRCUIT

DUAL GENERAL PURPOSE, LOW VOLTAGE, COMPARATORS

DESCRIPTION

The UTC **LMV393** is a low voltage (2.7-5V) version of the dual comparators. Its noise performance has been improved by using bipolar differential input and output stages. These comparators also have a unique characteristic in that the input common-mode voltage range includes ground even though operated from a single power supply voltage.

The UTC **LMV393** is designed for applications in consumer automotive, mobile communications, notebooks and PDA's, battery powered electronics, general purpose portable device, general purpose low voltage applications.

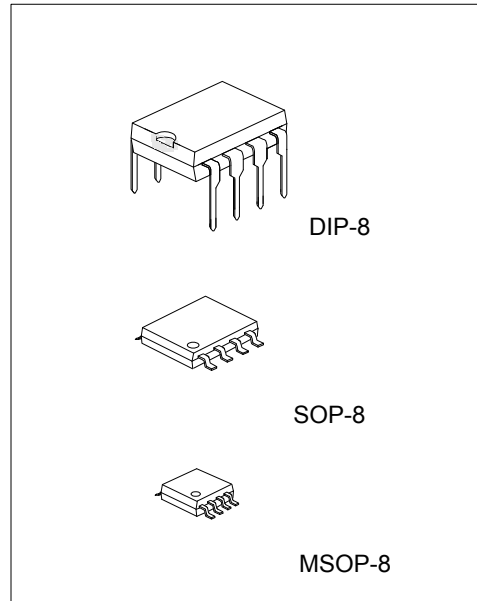

FEATURES

- * High Precision Comparator.
- * Low Operating Voltage 2.7-5V.
- * Low Supply Current 100µA/Channel (Typical).
- * Low Input Bias Current 100nA (Typical).
- * Low Input Offset Current 2nA (Typical).
- * Input Common Mode Voltage Range Includes Ground.
- * Low Output Saturation Voltage 0.2V.

ORDERING INFORMATION

Ordering Number		Package	Packing
Lead Free	Halogen Free		
LMV393L-D08-T	LMV393G-D08-T	DIP-8	Tube
-	LMV393G-S08-R	SOP-8	Tape Reel
-	LMV393G-SM1-R	MSOP-8	Tape Reel

<p>LMV393L-D08-R</p> <p>(1) Packing Type (2) Package Type (3) Green Package</p>	<p>(1) R: Tape Reel, T: Tube (2) D08: DIP-8, S08: SOP-8, SM1: MSOP-8 (3) L: Lead Free, G: Halogen Free and Lead Free</p>
---	--

MARKING

DIP-8	SOP-8 / MSOP-8
<p>UTC □□□□ LMV393□</p> <p>8 7 6 5 → Date Code L: Lead Free G: Halogen Free □□ → Lot Code</p> <p>1 2 3 4</p>	<p>UTC □□□□ LMV393G</p> <p>8 7 6 5 → Date Code ● □□ → Lot Code</p> <p>1 2 3 4</p>

■ PIN CONFIGURATION

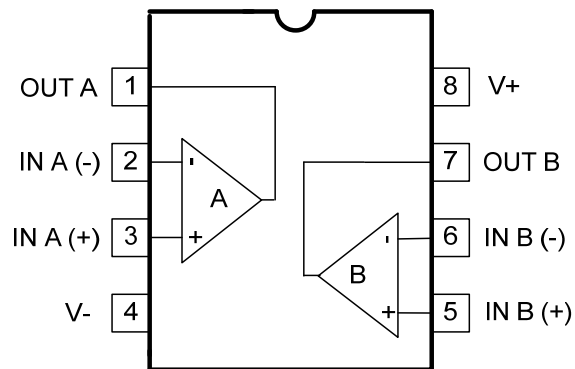

■ BLOCK DIAGRAM

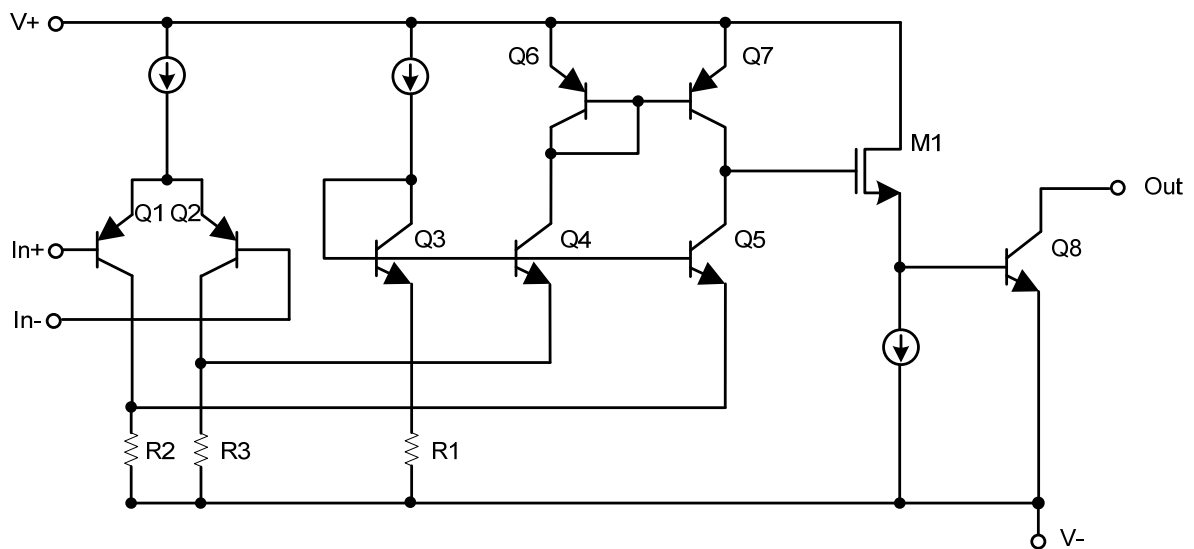

■ ABSOLUTE MAXIMUM RATINGS

PARAMETER	SYMBOL	RATINGS	UNIT
Supply Voltage	V_{CC}	2.7 ~ 5.0	V
Differential Input Voltage	$V_{IN(DIFF)}$	$\pm V_{CC}$	V
Voltage on Any Pin (Referred to V- pin)		5.5	V
Junction Temperature	T_J	+150	°C
Operating Temperature	T_{OPR}	-40 ~ +85	°C
Storage Temperature	T_{STG}	-65 ~ +150	°C

Note Absolute maximum ratings are those values beyond which the device could be permanently damaged. Absolute maximum ratings are stress ratings only and functional device operation is not implied.

■ THERMAL DATA

PARAMETER	SYMBOL	RATINGS	UNIT
Junction to Ambient	DIP-8	100	°C /W
	SOP-8	150	
	MSOP-8	190	

■ DC ELECTRICAL CHARACTERISTICS ($T_J=25^\circ\text{C}$, $V-=0\text{V}$, unless otherwise specified.)

PARAMETER	SYMBOL	TEST CONDITIONS	MIN	TYP	MAX	UNIT
Input Offset Voltage	$V_{I(OFF)}$			1.7	7	mV
Input Offset Voltage Average Drift	$I_{I(OFF)}$			5		$\mu\text{V}/^\circ\text{C}$
Input Bias Current	$I_{I(BIAS)}$			100	250	nA
Input Offset Current	$I_{I(OFF)}$			2	50	nA
Input Voltage Range	V_{IN}			-0.1 4.2		V
Supply Current	I_{CC}			100	200	μA
Voltage Gain	G_V		20	50		V/mV
Saturation Voltage	V_{SAT}	$I_{O(SINK)} \leq 4\text{mA}$		200	400	mV
Output Sink Current	$I_{O(SINK)}$	$V_{OUT} \leq 1.5\text{V}$	2.7V	5	40	mA
			5.0V	10	50	
Output Leakage Current	$I_{O(LEAK)}$			0.003	1	μA

■ AC ELECTRICAL CHARACTERISTICS ($T_J=25^\circ\text{C}$, $R_L=5.1\text{k}\Omega$, $V-=0\text{V}$, unless otherwise specified.)

PARAMETER	SYMBOL	TEST CONDITIONS	MIN	TYP	MAX	UNIT
Propagation Delay (High to Low)	t_{PHL}	Input Overdrive=10mV	2.7V	9		us
			5.0V	8		
		Input Overdrive=100mV	2.7V	3.8		
			5.0V	3.4		
Propagation Delay (Low to High)	t_{PLH}	Input Overdrive=10mV	2.7V	2		us
			5.0V	3		
		Input Overdrive=100mV	2.7V	0.7		
			5.0V	0.8		

■ APPLICATION CIRCUITS

Basic Comparator

A basic comparator circuit can convert analog signals to a digital output. The UTC **LMV393** needs a pull-up resistor connected to the positive supply voltage which can make output switch properly. So that when the internal output transistor is off, the output voltage will be pulled up to the external positive voltage.

The resistor should be chosen properly. The higher resistor can reduce the power dissipation. the lower resistor can improve the capacity of loading output. The range of resistor should between 1k to 10kΩ.

The Output voltage of the comparator will be high if the input voltage at the non-inverting pin is greater than the reference voltage at the inverting pin. On the other hand it will be low.

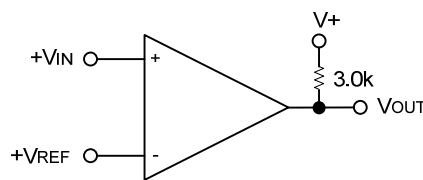
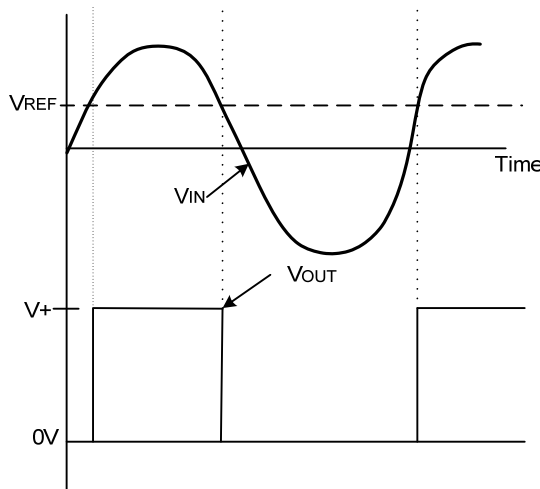

Basic Comparator

Comparator with Hysteresis

The comparator may oscillate or produce a noisy output if the applied differential input voltage is near the comparator's offset voltage, especially when the input signal is moving slowly across the comparator's switching threshold. Addition of hysteresis or positive feedback can solve this problem.

Inverting Comparator with Hysteresis

It requires a three resistor network that is referenced to the supply voltage V_{CC} of the comparator. When the output voltage is high, these resistors can be represented as $R_1 // R_3$ in series with R_2 . The lower set input voltage is defined as:

$$V_{a1} = \frac{V_{CC}R_2}{(R_1 // R_3) + R_2}$$

■ APPLICATION CIRCUITS(Cont.)

When $V_{IN} > V_a$ the output voltage is low close to ground. It can be presented as $R_2 // R_3$ in series with R_1 . The upper trip voltage V_{a2} is defined as

$$V_{a2} = \frac{V_{CC}(R_2 // R_3)}{(R_2 // R_3) + R_1}$$

The total hysteresis provided by the network is defined as:

$$\Delta V_a = V_{a1} - V_{a2}$$

To assure that the comparator will always switch correctly, the resistors values should be chosen as follow:

$R_{PULL-UP} \ll R_{LOAD}$ and $R_1 > R_{PULL-UP}$.

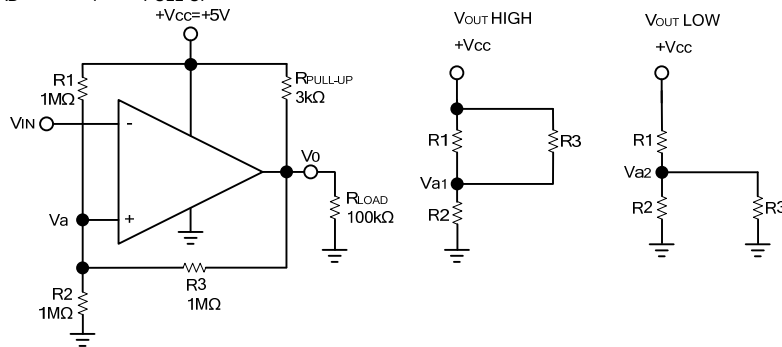

Inverting Comparator with Hysteresis

Non-Inverting Comparator with Hysteresis

It requires a two resistor network to implement a non inverting comparator with hysteresis and with a voltage reference at the inverting input. So when V_{IN} is low, the output is also low. If the output will switch from low to high, V_{IN} must rise up to V_{IN1} , and V_{IN1} can be calculated by:

$$V_{IN1} = \frac{V_{REF}(R_1 + R_2)}{R_2}$$

When V_{IN} is high, the output is also high, in order to make the comparator switch back to low, V_{IN} can be calculated by:

$$V_{IN2} = \frac{V_{REF}(R_1 + R_2) - V_{CC}R_1}{R_2}$$

The hysteresis of this circuit is the difference between V_{IN1} and V_{IN2} .

$$\Delta V_{IN} = V_{CC}R_1/R_2$$

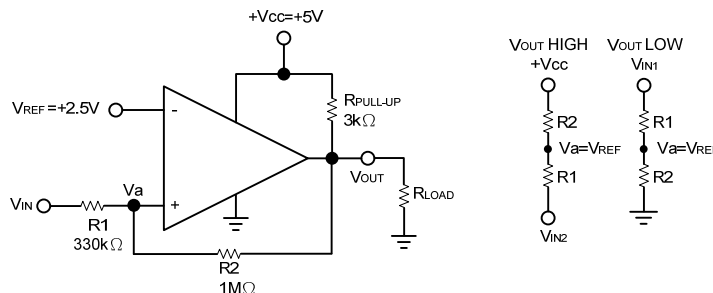

Non-Inverting Comparator with Hysteresis

■ APPLICATION CIRCUITS(Cont.)

Square Wave Oscillator

Comparators are suitable for oscillator applications. This application uses the minimum number of external components. The output frequency is set by the RC time constant which is determined by capacitor C1 and the resistor in the negative feedback R4 of the comparator. Capacitive load at the output would degrade the output slew rate and limit the maximum operating frequency.

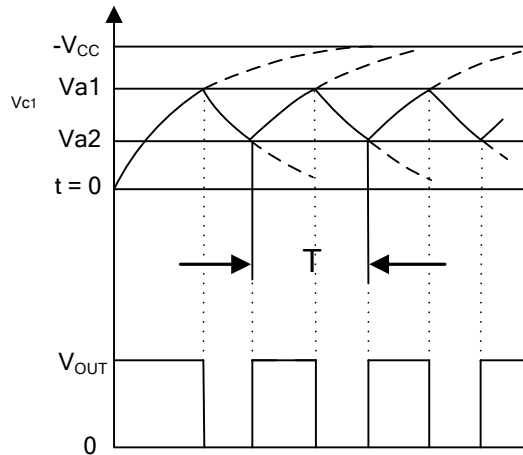
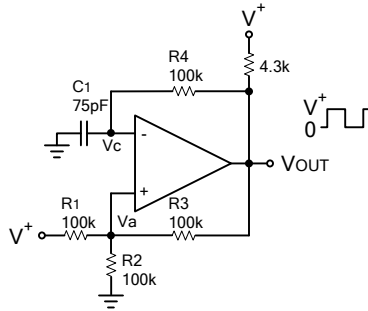

Squarewave Oscillator

At first, assume that the output is high, so the voltage at the inverting input V_C is less than the voltage at the non-inverting input V_a , the capacitor C_1 has to be discharged. When it has charged up to value equal to the positive input voltage V_{a1} , the comparator output will switch.

V_{a1} will be given by:

$$V_{a1} = \frac{V_{CC}R_2}{R_2 + (R_1/R_2)}$$

If: $R_1=R_2=R_3$

Then:

$$V_{a1} = \frac{2V_{CC}}{3}$$

When the output switches to ground, the value of V_a is reset by the resistor network:

$$V_{a2} = \frac{V_{CC}}{3}$$

Then capacitor C_1 discharge through a resistor towards ground. The output will return to its high state when the voltage across the capacitor has discharged to a value equal to V_{a2} .The time to charge the capacitor can be calculated from:

$$V_C = V_{max} e^{-\frac{t}{RC}}$$

Where $V_{MAX} = 2V_{CC}/3$ and $V_C = V_{CC}/3$

One period will be given by: $1/freq = 2t$ or calculating the exponential gives: $1/freq = 2(0.694) R_4 C_1$ Resistors R_3 and R_4 must be at least two times larger than R_5 to insure a reasonable V_O . The frequency stability of this circuit should strictly be a function of the external components.

■ APPLICATION CIRCUITS(Cont.)

Free Running Multivibrator

This oscillator circuit can generate a train of stable clock for precise timekeeping applications. We can obtain it by using a resonator as the feedback component. A quartz crystal in its series-resonant mode can make the circuit oscillating well. For the comparator be switching symmetrically about $+V_{CC}/2$, the value of R_1 and R_2 must choose equal. The RC time constant of R_3 and C_1 is set to be several times greater than the period of the oscillating frequency. When choose crystal, be sure to order series resonant with desired temperature coefficient.

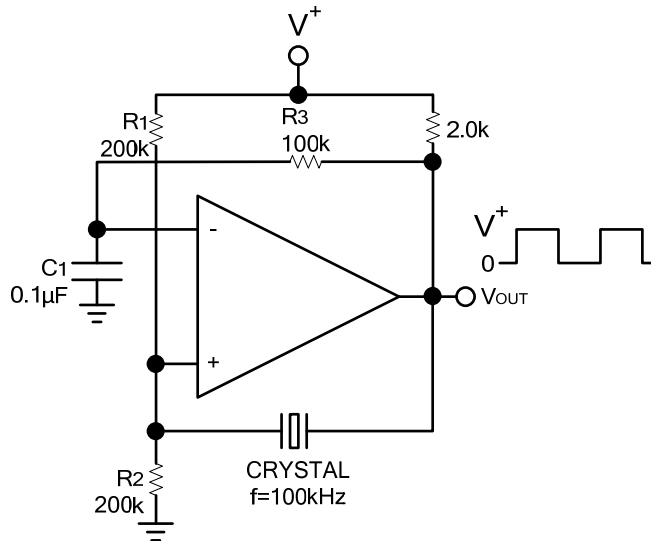

Crystal controlled Oscillator

Pulse generator with variable duty cycle:

A pulse generator with variable duty cycle can be obtained by creating two separated paths for C_1 charge and discharge into the basic square wave generator. One path, through R_2 and D_2 will charge the capacitor and set the pulse width (t_1). The other path, R_1 and D_1 will discharge the capacitor and set the time between pulses (t_2).

Varying resistor R_1 , R_2 can alter the time between pulses and the pulse width. Both controls also change the frequency of the generator.

The pulse width and time between pulses can be found from:

$$V_1 = V_{max} (1 - e^{-t_1/R_4 C_1}) \quad \text{Rise time}$$

$$V_1 = V_{max} (1 - e^{-t_2/R_5 C_1}) \quad \text{Fall time}$$

Where

$$V_{max} = \frac{2V_{CC}}{3}$$

And

$$V_1 = \frac{2V_{max}}{3} = \frac{V_{CC}}{3}$$

then

$$\frac{1}{2} = e^{-t_1/R_4 C_1}$$

t_2 is then given by:

$$\frac{1}{2} = e^{-t_2/R_5 C_1}$$

■ APPLICATION CIRCUITS(Cont.)

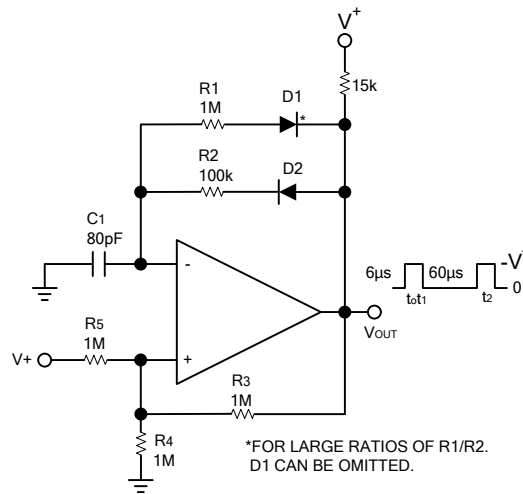

Pulse Generator

At last, we get,

$$t_1 = R_4 C_1 \ln 2$$

$$t_2 = R_5 C_1 \ln 2$$

These terms have a slight error because V_{max} is not exactly equal to $2/3 V_{CC}$ but is actually reduced by the diode drop to:

$$V_{max} = \frac{2}{3}(V_{CC} - V_{BE})$$

$$\frac{1}{2(1 - V_{BE})} = e^{-t_1/R_4 C_1}$$

$$\frac{1}{2(1 - V_{BE})} = e^{-t_2/R_5 C_1}$$

And that's the exact value we get.

$$t_1 = R_4 C_1 \ln 2(1 - V_{BE})$$

$$t_2 = R_5 C_1 \ln 2(1 - V_{BE})$$

■ APPLICATION CIRCUITS(Cont.)

Positive Peak Detector:

Positive peak detector is basically the comparator operated as a unit gain follower with a large holding capacitor from the output to ground. Additional transistor is added to the output to provide a low impedance current source. When the output of the comparator goes high, current is passed through the transistor to charge up the capacitor. The only discharge path will be the 1M ohm resistor shunting C1 and any load that is connected to the output. The decay time can be altered simply by changing the 1MΩ resistor. The output should be used through a high impedance follower to avoid loading the output of the peak detector.

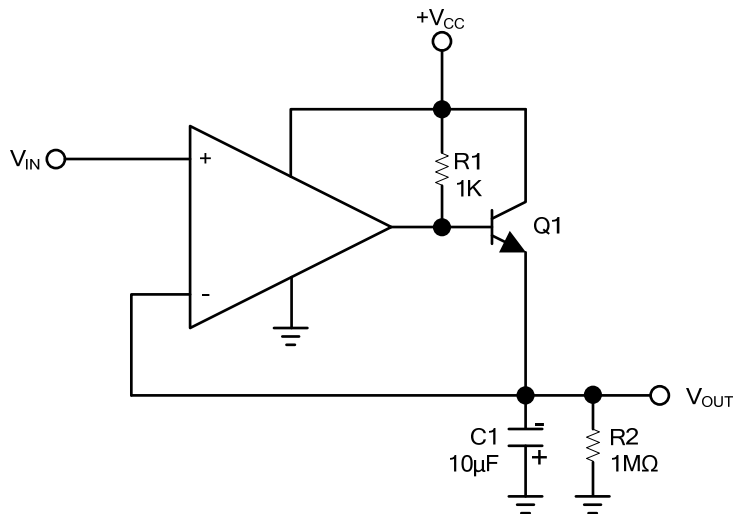

Positive Peak Detector

Negative Peak Detector:

For the negative detector, the output transistor of the comparator acts as a low impedance current sink. The only discharge path will be the 1MΩ resistor and any load impedance used. Decay time is changed by varying the 1MΩ resistor.

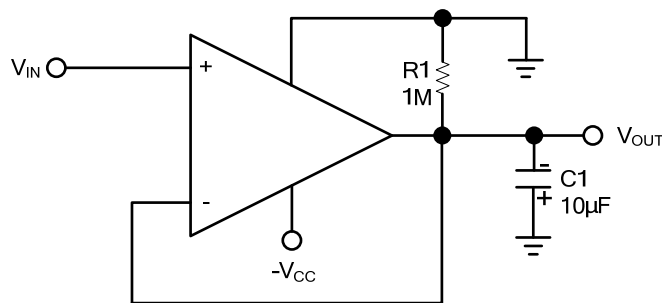

Negative Peak Detector

■ TYPICAL CHARACTERISTICS

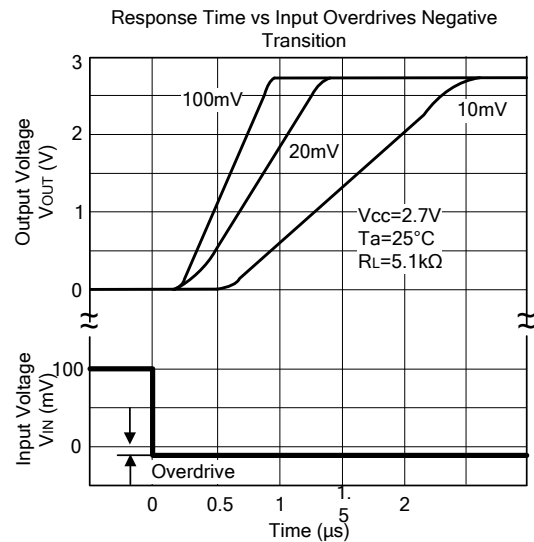
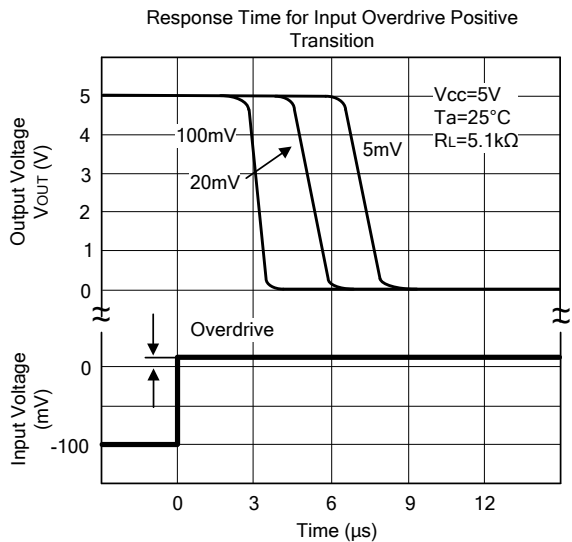
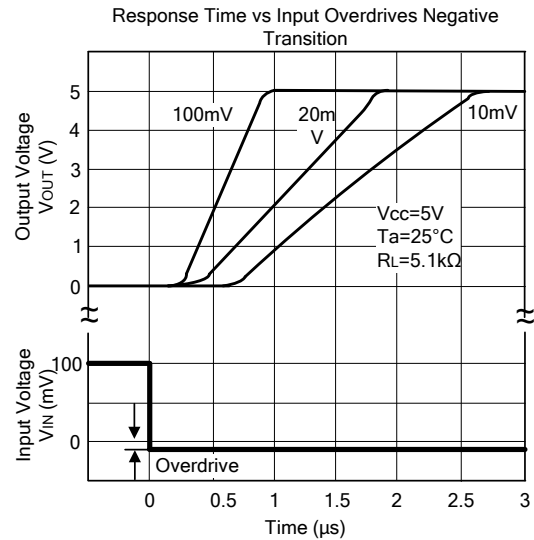
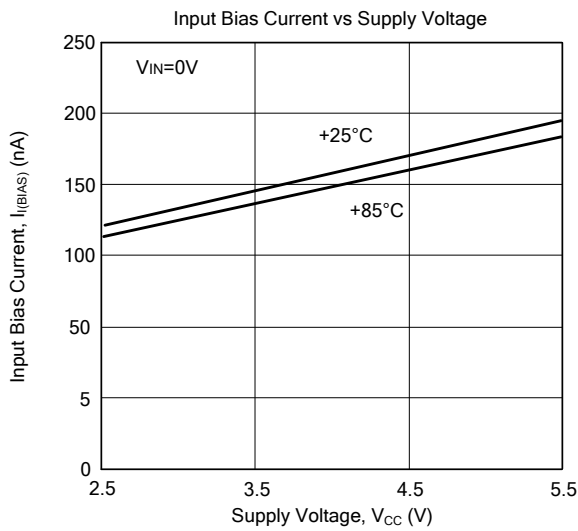
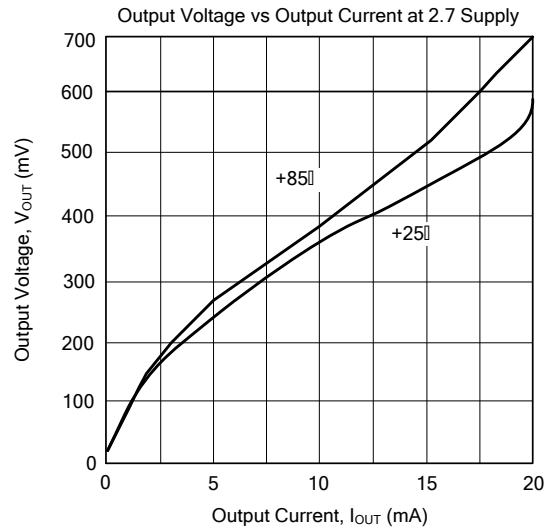
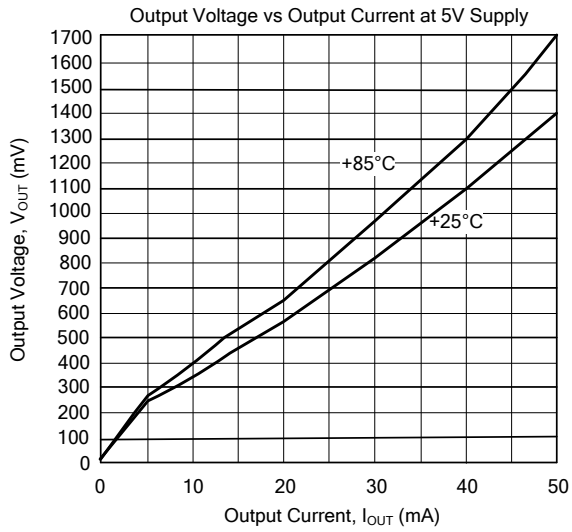

■ TYPICAL CHARACTERISTICS (Cont.)

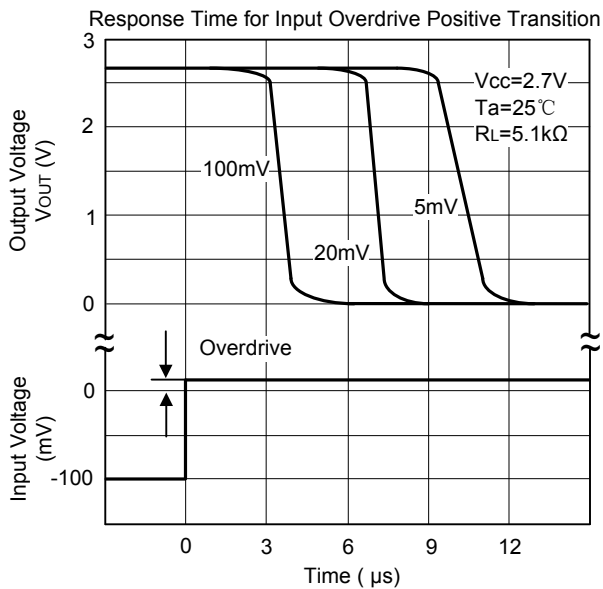

UTC assumes no responsibility for equipment failures that result from using products at values that exceed, even momentarily, rated values (such as maximum ratings, operating condition ranges, or other parameters) listed in products specifications of any and all UTC products described or contained herein. UTC products are not designed for use in life support appliances, devices or systems where malfunction of these products can be reasonably expected to result in personal injury. Reproduction in whole or in part is prohibited without the prior written consent of the copyright owner. The information presented in this document does not form part of any quotation or contract, is believed to be accurate and reliable and may be changed without notice.

X-ON Electronics

Largest Supplier of Electrical and Electronic Components

Click to view similar products for [Analog Comparators](#) category:

Click to view products by [Unisonic](#) manufacturer:

Other Similar products are found below :

[SC2903VDR2G](#) [LM2901SNG](#) [LM339SNG](#) [5962-8757203IA](#) [NTE911](#) [LM339EDR2G](#) [NTE922](#) [UPC311G2-E1-A](#) [UPC311G2-E2-A](#)
[UPC272G2-E1-A](#) [UPC277G2-E2-A](#) [UPC177G2-E2-A](#) [UPC271G2-E2-A](#) [TLV1811DBVR](#) [HT393VRMZ](#) [LM2903YD](#) [NCV2200SN1T1G](#)
[LM2903A-SR](#) [LM2903A-VR](#) [HT393ARZ](#) [LM2903](#) [LM2904](#) [LM393D](#) [LM393](#) [LMV331SN3T1G](#) [LMV331ILT](#) [LMV331W5](#)
[LMV331IDBVR](#) [LMV331M5X](#) [TPV331S5](#) [LM339A-SR](#) [GS8748-SR](#) [LM311MM/TR](#) [LM211MM/TR](#) [HT339ARQZ](#) [LM393DR-HXY](#)
[LM2903XK-Q1](#) [RS393XK-Q1](#) [LM2903XM](#) [RS339XQ](#) [LM331CXF](#) [RS393XM](#) [LM2901XP](#) [LM2901DR-JSM](#) [LM239DR-JSM](#) [LM339](#)
[LR2903D](#) [TS391IL](#) [LM331A-S5TR](#) [GSV331R-TR](#)