



## LP2950/2951

## LINEAR INTEGRATED CIRCUIT

### 100 mA LOW-DROPOUT VOLTAGE REGULATOR

#### DESCRIPTION

The UTC **LP2950/2951** are monolithic integrated voltage regulators with low dropout voltage, and low quiescent current. It includes many features that suitable for different applications.

#### FEATURES

- \* Fixed output versions, 2.5V, 3.0V, 3.3V, 3.6V and 5.0V, are available
- \* High accuracy output voltage
- \* Extremely low quiescent current and dropout voltage
- \* Extremely tight load and line regulation
- \* Current and thermal limiting
- \* Very low temperature coefficient
- \* Logic controlled shutdown and err flog available for 8 pin package
- \* Output voltage programmable for **LP2951**

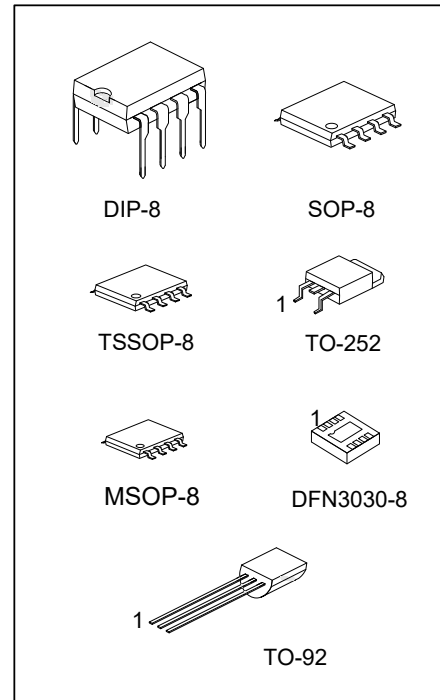

#### ORDERING INFORMATION

Ordering Number		Package	Packing
Lead Free	Halogen Free		
LP2950L-xx-D08-T	LP2950G-xx-D08-T	DIP-8	Tube
LP2950L-xx-S08-R	LP2950G-xx-S08-R	SOP-8	Tape Reel
LP2950L-xx-T92-B	LP2950G-xx-T92-B	TO-92	Tape Box
LP2950L-xx-T92-K	LP2950G-xx-T92-K	TO-92	Bulk
LP2950L-xx-TN3-R	LP2950G-xx-TN3-R	TO-252	Tape Reel
LP2950L-xx-K08-3030-R	LP2950G-xx-K08-3030-R	DFN3030-8	Tape Reel
LP2951L-D08-T	LP2951G-D08-T	DIP-8	Tube
LP2951L-S08-R	LP2951G-S08-R	SOP-8	Tape Reel
LP2951L-SM1-R	LP2951G-SM1-R	MSOP-8	Tape Reel
LP2951L-P08-R	LP2951G-P08-R	TSSOP-8	Tape Reel
LP2951L-K08-3030-R	LP2951G-K08-3030-R	DFN3030-8	Tape Reel
LP2951L-xx-S08-R	LP2951G-xx-S08-R	SOP-8	Tape Reel

Note: Pin Assignment: I: V<sub>IN</sub> O: V<sub>OUT</sub> G: GND

<p>LP2950G-xx-D08-T</p> <p>(1)Packing Type (2)Package Type (3)Output Voltage Code (4)Green Package</p>	<p>(1) T: Tube, B: Tape Box, K: Bulk, R: Tape Reel (2) D08: DIP-8, S08: SOP-8, SM1: MSOP-8, P08: TSSOP-8, TN3: TO-252, T92: TO-92, K08-3030: DFN3030-8 (3) xx: refer to Output Voltage Code (4) G: Halogen Free and Lead Free, L: Lead Free</p>
--	---

■ MARKING INFORMATION (For LP2950)

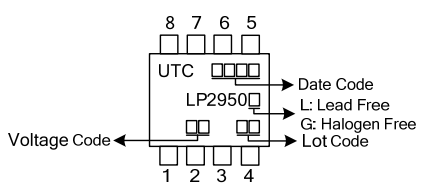
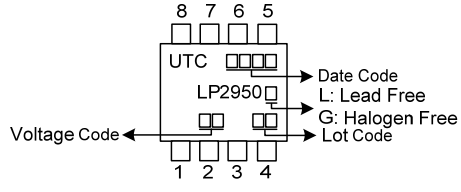
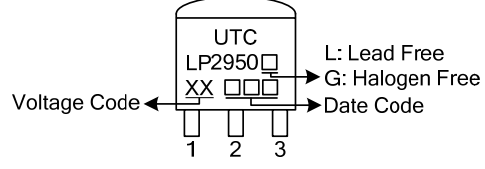
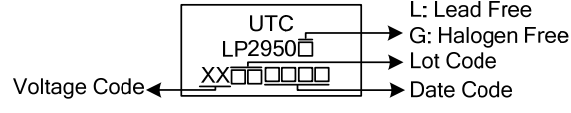
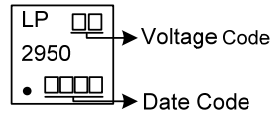
PACKAGE	VOLTAGE CODE	MARKING
DIP-8	25: 2.5V 30: 3.0V 33: 3.3V 36: 3.6V 50: 5.0V	
SOP-8		
TO-92		
TO-252		
DFN3030-8		

■ MARKING INFORMATION (For LP2951)

DIP-8	SOP-8
MSOP-8	TSSOP-8
DFN3030-8	-
	-

■ MARKING INFORMATION (For LP2951)

PACKAGE	VOLTAGE CODE	MARKING
SOP-8	33: 3.3V	

## PIN CONFIGURATIONS

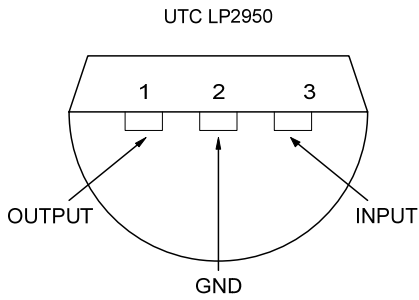

TO-92 Plastic Package Bottom View

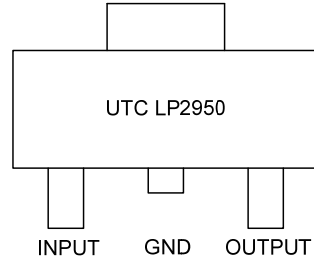

TO-252 Package

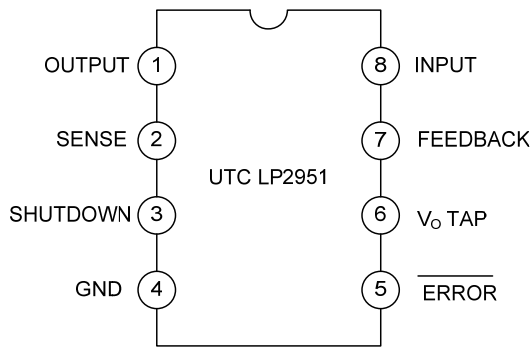

DIP-8, SOP-8 or TSSOP-8 Package For UTC LP2951

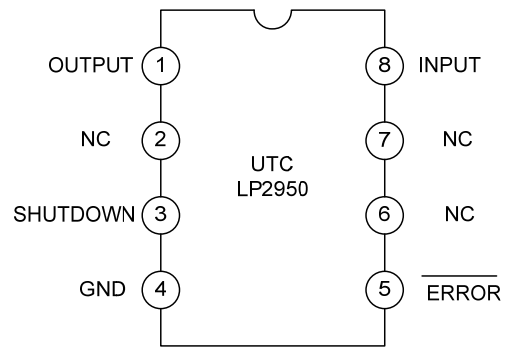

DIP-8, SOP-8 Package For UTC LP2950

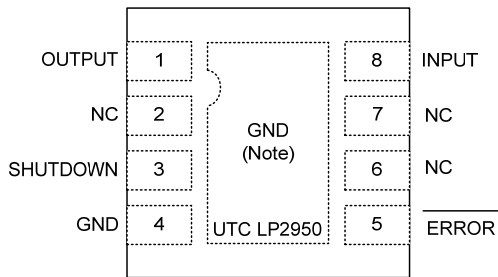

DFN3030-8 Plastic Package Top View

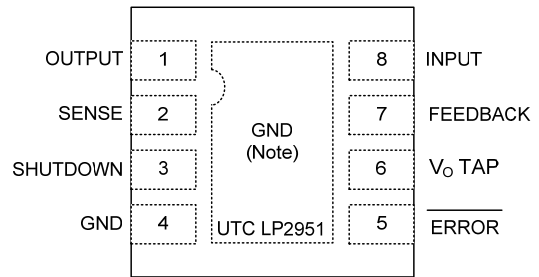

DFN3030-8 Plastic Package Top View

Note: Connect exposed pad to GND.

## ■ BLOCK DIAGRAM

### FOR LP2950

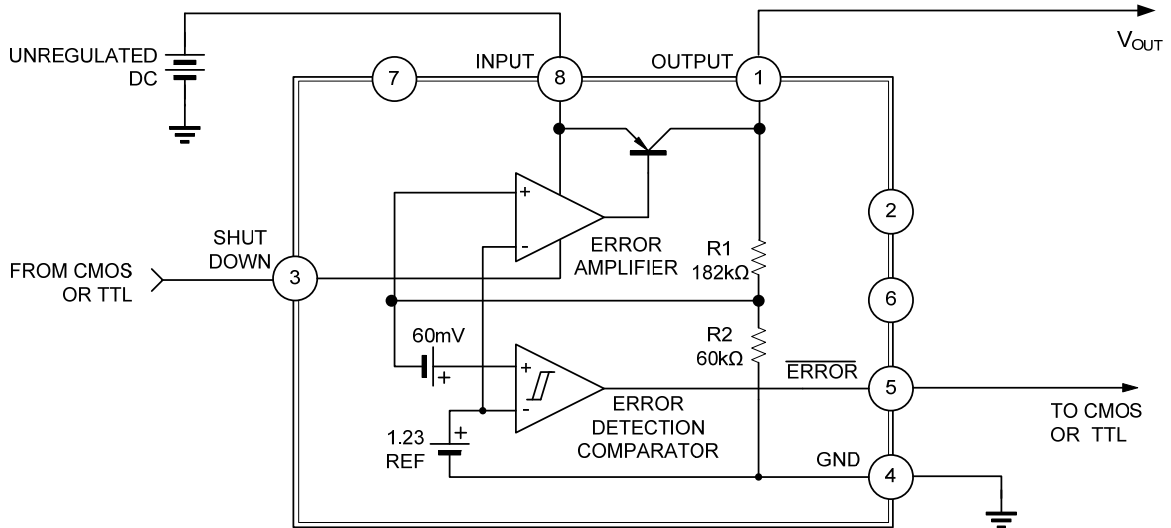

### FOR LP2951

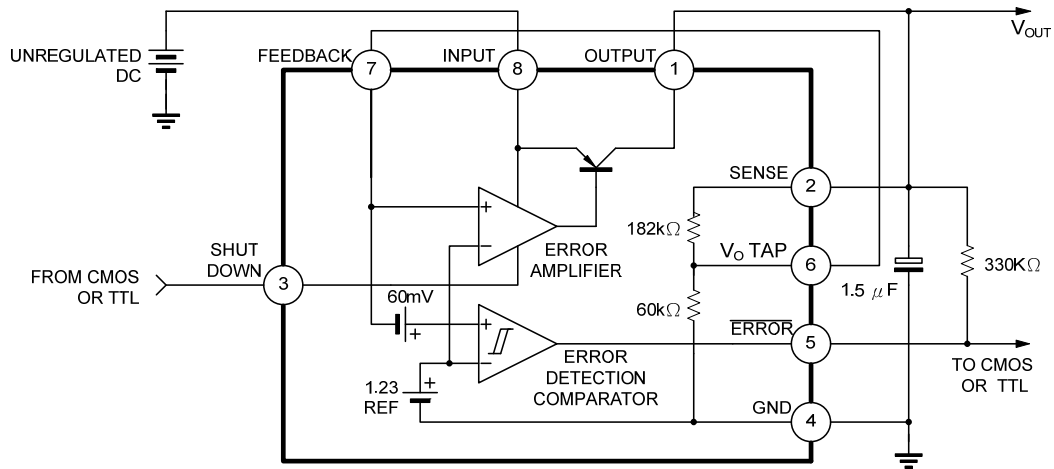

### ■ ABSOLUTE MAXIMUM RATINGS

PARAMETER	SYMBOL	RATINGS	UNIT
Supply Voltage	$V_{CC}$	-0.3 ~ +30	V
Feedback Voltage	$V_{FB}$	-1.5 ~ +30	V
Shutdown Voltage	$V_{SHDN}$	-0.3 ~ +30	V
Power Dissipation	$P_D$	Internally Limited	W
Operation Junction Temperature	$T_J$	-40 ~ +125	°C
Storage Temperature	$T_{STG}$	-65 ~ +150	°C

Note: Absolute maximum ratings are those values beyond which the device could be permanently damaged. Absolute maximum ratings are stress ratings only and functional device operation is not implied.

### ■ THERMAL DATA

PARAMETER	SYMBOL	RATING	UNIT
Junction-to-Ambient	TO-92	180	°C/W
	TO-252	92	°C/W
	TSSOP-8	150	°C/W
	MSOP-8	190	°C/W
	SOP-8	143	°C/W
	DIP-8	105	°C/W
	DFN3030-8	64 (Note)	°C/W
Junction-to-Case	TO-92	83	°C/W
	TO-252	6	°C/W
	TSSOP-8	50	°C/W
	MSOP-8	55	°C/W
	SOP-8/DIP-8	45	°C/W
	DFN3030-8	9 (Note)	°C/W

Note: The data tested by surface mounted on a 2 inch<sup>2</sup> FR-4 board with 2OZ copper.

### ■ ELECTRICAL CHARACTERISTICS ( $T_J=25^\circ\text{C}$ , $V_{IN}=6\text{V}$ , $I_L=100\mu\text{A}$ , $C_L=1\mu\text{F}$ , unless otherwise specified.)

#### For All Version:

PARAMETER	SYMBOL	TEST CONDITION	MIN	TYP	MAX	UNIT
Output Voltage	$V_{OUT}$	$T_J=25^\circ\text{C}$ (Note 1)	$V_{OUT}\times 0.98$	$V_{OUT}$	$V_{OUT}\times 1.02$	V
Output Voltage	$V_{OUT}$	$100\mu\text{A}\leq I_L\leq 100\text{mA}$ , $T_J\leq T_J(\text{max})$	$V_{OUT}\times 0.98$	$V_{OUT}$	$V_{OUT}\times 1.02$	V
Output Voltage Temperature Coefficient	$T_C V_O$		20		100	ppm/°C
Line Regulation	$\Delta V_{OUT}$	$6\text{V}\leq V_{IN}\leq 30\text{V}$	0.03	0.1	0.2	%
Load Regulation	$\Delta V_{OUT}$	$100\mu\text{A}\leq I_L\leq 100\text{mA}$	0.04	0.1	0.2	%
Dropout Voltage	$V_D$	$I_L=100\mu\text{A}$	50	80	150	mV
		$I_L=100\text{mA}$ (Note 2)	380	450	600	mV
Ground Current	$I_G$	$I_L=100\mu\text{A}$		120	140	$\mu\text{A}$
		$I_L=100\text{mA}$		12	14	mA
Dropout Ground Current		$V_{IN}=(V_{ONOM}-0.5)\text{V}$ , $I_L=100\mu\text{A}$		170	200	$\mu\text{A}$
Current Limit	$I_{LIMIT}$	$V_{OUT}=0$	130	190	250	mA
Output Noise (10Hz ~ 100KHz) (Bypass=0.01 $\mu\text{F}$ pins 7 to 1 (LP2951))	eN	$C_L=1\mu\text{F}$			430	$\mu\text{V}$
		$C_L=200\mu\text{F}$			160	$\mu\text{V}$
		$C_L=3.3\mu\text{F}$			100	$\mu\text{V}$

### ■ ELECTRICAL CHARACTERISTICS(Cont.)

#### For UTC LP2950 8-Pin Version Only

PARAMETER	SYMBOL	TEST CONDITION	MIN	TYP	MAX	UNIT
<b>Error Comparator</b>						
Output Leakage Current	$I_{O(LEAK)}$	$V_{OH}=30V$			1	$\mu A$
Output Low Voltage	$V_{OL}$	$V_{IN}=(V_{O(NOM)} - 0.5)V, I_{OL}=400\mu A$			280	mV
Threshold Voltage	Upper	$V_{THU}$ (Note 3)	3.2			%VO
	Lower	$V_{THL}$ (Note 3)			7.6	%VO
Hysteresis	$V_{HYS}$	(Note 3)		15		mV
<b>Shutdown Input</b>						
Input Logic Voltage	Low	$V_{IL}$	Regulator ON		0.70	V
	High	$V_{IH}$	Regulator OFF	2.0		V
Shutdown Pin Input Current	$I_{SHDN}$	$V_{SHDN}=2.4V$		30	50	$\mu A$
		$V_{SHDN}=30V$		450	600	$\mu A$
Regulator Output Current Shutdown	$I_{DFF}$	$V_{SHDN} \geq 2V, V_{IN} \leq 30V, V_{OUT}=0$ Feedback pin tied to $V_O$ Tap.		3	10	$\mu A$

#### For UTC LP2951 8-Pin Version Only

PARAMETER	SYMBOL	TEST CONDITION	MIN	TYP	MAX	UNIT
Reference Voltage	$V_{REF}$		1.22	1.235	1.25	V
Reference Voltage	$V_{REF}$	Over temperature(Note 4)	1.19		1.27	V
Feedback pin Bias Current	$I_{FB}$			20	40	nA
Reference Voltage Temperature Coefficient	$V_{REF(TC)}$			50		ppm/ $^{\circ}C$
Feedback Bias Current Temperature Coefficient	$I_{FB(TC)}$			0.1		nA/ $^{\circ}C$
<b>Error Comparator</b>						
Output Leakage Current	$I_{O(LEAK)}$	$V_{OH}=30V$			1	$\mu A$
Output Low Voltage	$V_{OL}$	$V_{IN}=(V_{O(NOM)} - 0.5)V, I_{OL}=400\mu A$			250	mV
Threshold Voltage	Upper	$V_{THU}$ (Note 3)	3.2			%VO
	Lower	$V_{THL}$ (Note 3)			7.6	%VO
Hysteresis	$V_{HYS}$	(Note 3)		15		mV
<b>Shutdown Input</b>						
Input Logic Voltage	Low	$V_{IL}$	Regulator ON		0.70	V
	High	$V_{IH}$	Regulator OFF	2.0		V
Shutdown Pin Input Current	$I_{SHDN}$	$V_{SHDN}=2.4V$		30	50	$\mu A$
		$V_{SHDN}=30V$		450	600	$\mu A$
Regulator Output Current Shutdown	$I_{DFF}$	$V_{SHDN} \geq 2V, V_{IN} \leq 30V, V_{OUT}=0$ Feedback pin tied to $V_O$ Tap.		3	10	$\mu A$

Note: 1. Additional conditions for 8-pin versions are FB pin tied to  $V_O$  Tap, Output tied to Sense ( $V_{OUT}=3.3V$  or  $5V$ ) and  $V_{SHDN} \leq 0.8V$ .

2. Dropout Voltage is defined as the input to output differential at which the output voltage drops 100mV below its nominal value measured at 1V differential.

3. Comparator thresholds are expressed in terms of percentage value of voltage output.

4.  $V_{REF} \leq V_{OUT} \leq (V_{IN} - 1V)$ ,  $2.3V \leq V_{IN} \leq 30V$ ,  $100\mu A \leq I_L \leq 100mA$ ,  $T_J \leq T_{J(MAX)}$

■ TYPICAL APPLICATION CIRCUIT  
**100 Ampere Low Dropout Regulator**

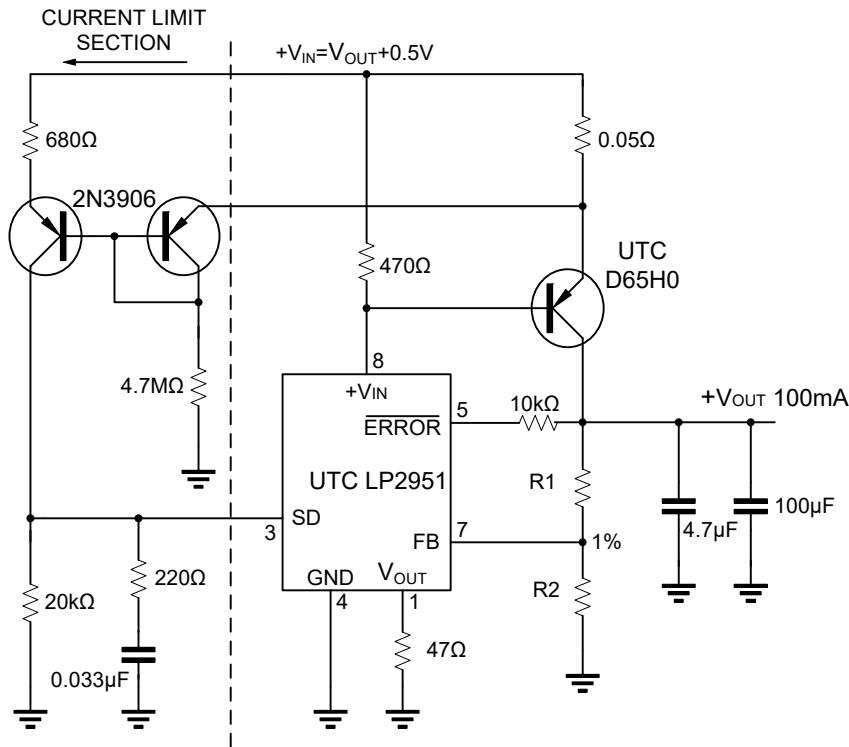

$V_{OUT} = 1.23V \times (1 + R1/R2)$   
 For  $V_O$  TAP output use internal resistors. Wire pin 6 to 7 and wire pin 2 to  $+V_{OUT}$

Fig.1

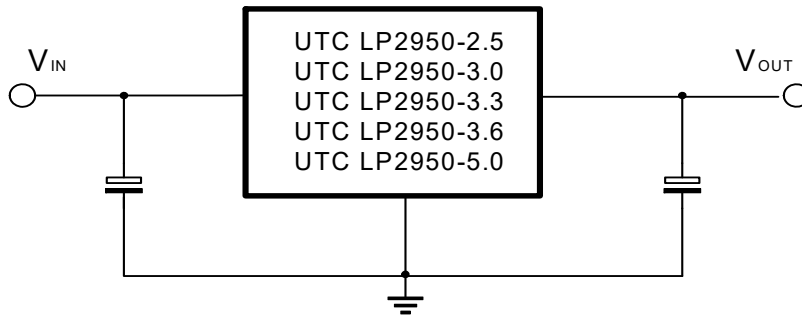

Fig.2

UTC assumes no responsibility for equipment failures that result from using products at values that exceed, even momentarily, rated values (such as maximum ratings, operating condition ranges, or other parameters) listed in products specifications of any and all UTC products described or contained herein. UTC products are not designed for use in life support appliances, devices or systems where malfunction of these products can be reasonably expected to result in personal injury. Reproduction in whole or in part is prohibited without the prior written consent of the copyright owner. UTC reserves the right to make changes to information published in this document, including without limitation specifications and product descriptions, at any time and without notice. This document supersedes and replaces all information supplied prior to the publication hereof.



## X-ON Electronics

Largest Supplier of Electrical and Electronic Components

*Click to view similar products for [Linear Voltage Regulators](#) category:*

*Click to view products by [Unisonic](#) manufacturer:*

Other Similar products are found below :

[LV5684PVD-XH](#) [MCDTSA6-2R](#) [L7815ACV-DG](#) [LV56801P-E](#) [UA7805CKC](#) [714954EB](#) [ZMR500QFTA](#) [BA033LBSG2-TR](#)  
[NCV78M05ABDTRKG](#) [LV5680P-E](#) [L79M05T-E](#) [L78LR05D-MA-E](#) [NCV317MBTG](#) [NTE7227](#) [MP2018GZD-33-P](#) [MP2018GZD-5-P](#)  
[LV5680NPVC-XH](#) [ZTS6538SE](#) [UA78L09CLP](#) [UA78L09CLPR](#) [CAT6221-PPTD-GT3](#) [MC78M09CDTRK](#) [NCV51190MNTAG](#)  
[BL1118CS8TR1833](#) [BL8077CKETR33](#) [BL9153-33CC3TR](#) [BL9161G-28BADRN](#) [BRCO7530MMC](#) [CJ7815B-TFN-ARG](#) [LM317C](#)  
[GM7333K](#) [GM7350K](#) [XC6206P332MR](#) [HT7533](#) [LM7912S/TR](#) [LT1764S/TR](#) [LM7805T](#) [LM338T](#) [LM1117IMP-3.3/TR](#) [HT1117AM-3.3](#)  
[HT7550S](#) [AMS1117-3.3](#) [HT7150S](#) [78L12](#) [HT7550](#) [HT7533-1](#) [HXY6206I-2.5](#) [HT7133](#) [HT7533S](#) [662K](#)