



LR1106

CMOS IC

LARGE CURRENT POSITIVE VOLTAGE REGULATORS

DESCRIPTION

The UTC **LR1106** series are positive voltage regulators that developed in CMOS technology with highly precise, low power consumption. It is capable of large currents with a significantly small dropout voltage.

The device consists of a driver transistor, a precision reference voltage and an error amplifier. Basically, output voltage is selectable in 0.1V step form 1.5V to 6.0V, 2.85V also is available.

FEATURES

- * Maximum Output Current : 400mA
- * Maximum Operating Voltage: 8V
- * Highly Accurate : ± 2%
- * Output Voltage Temperature Characteristics : TYP ±100ppm/°C

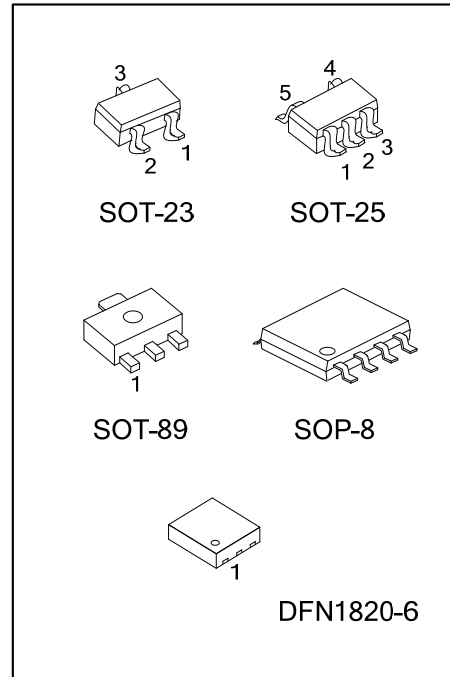

ORDERING INFORMATION

Ordering Number		Package	Pin Assignment								Packing
Lead Free	Halogen Free		1	2	3	4	5	6	7	8	
LR1106L-xx-AB3-B-R	LR1106G-xx-AB3-B-R	SOT-89	O	G	I	-	-	-	-	-	Tape Reel
LR1106L-xx-AB3-C-R	LR1106G-xx-AB3-C-R	SOT-89	G	I	O	-	-	-	-	-	Tape Reel
LR1106L-xx-AE3-3-R	LR1106G-xx-AE3-3-R	SOT-23	O	G	I	-	-	-	-	-	Tape Reel
LR1106L-xx-AF5-R	LR1106G-xx-AF5-R	SOT-25	I	G	E	N	O	-	-	-	Tape Reel
LR1106L-xx-S08-R	LR1106G-xx-S08-R	SOP-8	O	N	G	N	E	N	N	I	Tape Reel
LR1106L-xx-K06-1820-R	LR1106G-xx-K06-1820-R	DFN1820-6	I	N	O	N	G	E	-	-	Tape Reel

Note: Pin Assignment: I: V_{IN} O: V_{OUT} G: GND N: No Connection E: Enable
 xx: Output Voltage, refer to Marking Information.

<p>LR1106G-xx-AB3-B-R</p>	<p>(1) R: Tape Reel (2) Refer to Pin Assignment (3) AB3: SOT-89, AE3: SOT-23, AF5: SOT-25, S08: SOP-8 K06-1820: DFN1820-6 (4) xx: Refer to Marking Information (5) G: Halogen Free and Lead Free</p>
---------------------------	---

MARKING INFORMATION

PACKAGE	VOLTAGE CODE	MARKING
SOT-23	15:1.5V 18:1.8V 22:2.2V 25:2.5V 27:2.7V 28:2.8V 2J:2.85V 30:3.0V 31:3.1V 33:3.3V 50:5.0V	
SOT-25		
SOT-89		
SOP-8		
DFN1820-6		

■ BLOCK DIAGRAM

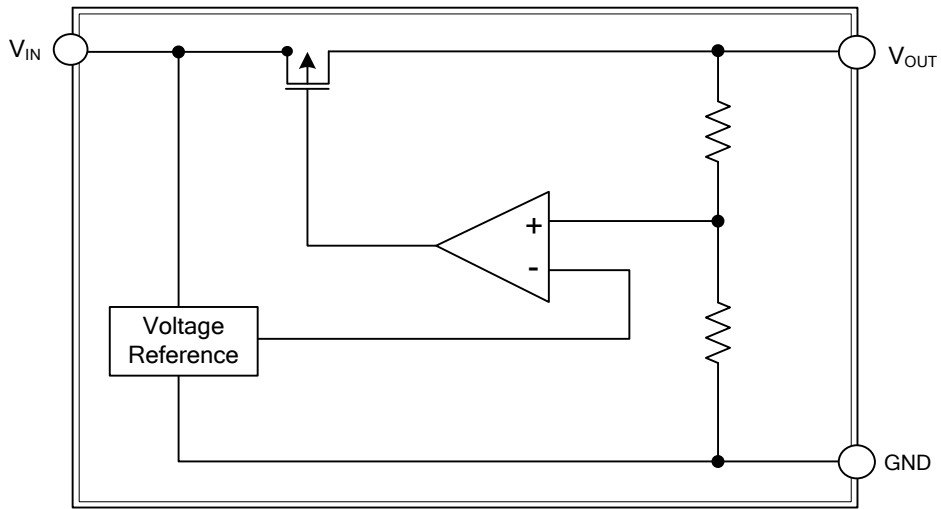

For SOT-89 / SOT-23 Package

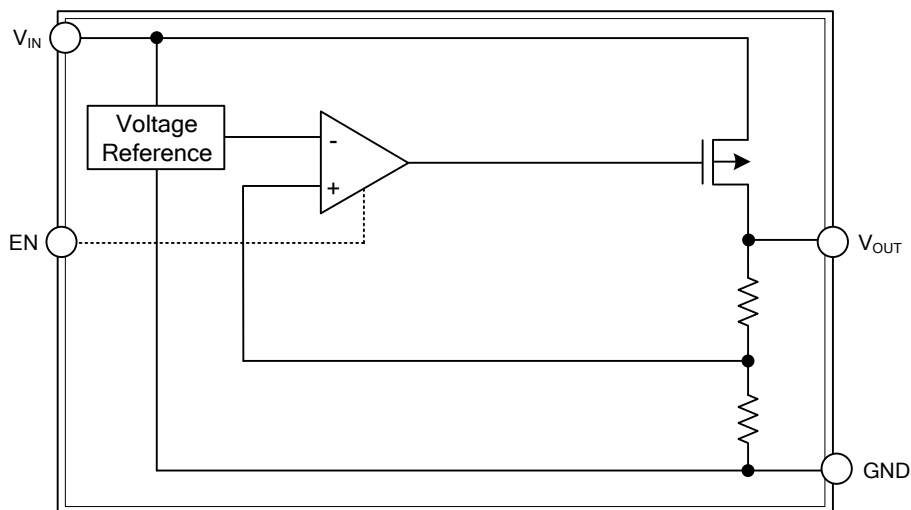

For SOP-8 / DFN1820-6 / SOT-25 Package

■ ABSOLUTE MAXIMUM RATINGS (T_A=25°C, unless otherwise specified)

PARAMETER	SYMBOL	RATINGS	UNIT
Input Voltage	V _{IN}	8	V
Output Voltage	V _{OUT}	V _{SS} -0.3 ~ V _{IN} +0.3	V
Output Current	I _{OUT}	400	mA
Power Dissipation	SOT-25/SOT-23	300	mW
	SOT-89/SOP-8	500	mW
	DFN1820-6	1000	mW
Operating Ambient Temperature	T _{OPR}	-40 ~ +85	°C
Storage Temperature	T _{STG}	-40 ~ +125	°C

Note: Absolute maximum ratings are those values beyond which the device could be permanently damaged.

Absolute maximum ratings are stress ratings only and functional device operation is not implied.

■ ELECTRICAL CHARACTERISTICS (T_A=25°C, unless otherwise specified.)

For LR1106-15

PARAMETER	SYMBOL	TEST CONDITIONS	MIN	TYP	MAX	UNIT
Output Voltage	V _{OUT}	V _{IN} =2.5V, I _{OUT} =40mA	1.470	1.500	1.530	V
Input Voltage	V _{IN}				8	V
Load Regulation	ΔV _{OUT}	V _{IN} =2.5V, 1mA≤I _{OUT} ≤200mA		40	100	mV
Dropout Voltage	V _{D1}	I _{OUT} =100mA		200	300	mV
	V _{D2}	I _{OUT} =200mA		400	600	
Maximum Output Current	I _{OUT(MAX)}	V _{IN} =2.5V, V _{OUT} ≥V _{OUT} × 0.90	400			mA
Supply Current	I _{SS}	V _{IN} =2.5V, V _{EN} =V _{IN}		30.0	50.0	μA
EN Input Bias Current	I _{EH}	V _{EN} =V _{IN}			0.1	μA
	I _{EL}	V _{EN} =0, V _{IN} =2.5V to 8V		1.0	3.0	
EN Input Threshold	V _{EH}	V _{IN} =2.5V to 8V	V _{IN} /2+0.8		V _{IN}	V
	V _{EL}	V _{IN} =2.5V to 8V	0		0.4	
Line Regulation	$\frac{\Delta V_{OUT}}{\Delta V_{IN} \times V_{OUT}}$	I _{OUT} =40mA, 2.5V≤V _{IN} ≤8.0V		0.2	0.5	%/V
Output Voltage Temperature Characteristics	$\frac{\Delta V_{OUT}}{\Delta T_{OPR} \times V_{OUT}}$	I _{OUT} =40mA		±100		ppm/°C

For LR1106-18

PARAMETER	SYMBOL	TEST CONDITIONS	MIN	TYP	MAX	UNIT
Output Voltage	V _{OUT}	V _{IN} =2.8V, I _{OUT} =40mA	1.764	1.800	1.836	V
Input Voltage	V _{IN}				8	V
Load Regulation	ΔV _{OUT}	V _{IN} =2.8V, 1mA≤I _{OUT} ≤200mA		40	100	mV
Dropout Voltage	V _{D1}	I _{OUT} =100mA		200	300	mV
	V _{D2}	I _{OUT} =200mA		400	600	
Maximum Output Current	I _{OUT(MAX)}	V _{IN} =2.8V, V _{OUT} ≥V _{OUT} × 0.90	400			mA
Supply Current	I _{SS}	V _{IN} =2.8V, V _{EN} =V _{IN}		30.0	50.0	μA
EN Input Bias Current	I _{EH}	V _{EN} =V _{IN}			0.1	μA
	I _{EL}	V _{EN} =0, V _{IN} =2.8V to 8V		1.0	3.0	
EN Input Threshold	V _{EH}	V _{IN} =2.8V to 8V	V _{IN} /2+0.8		V _{IN}	V
	V _{EL}	V _{IN} =2.8V to 8V	0		0.4	
Line Regulation	$\frac{\Delta V_{OUT}}{\Delta V_{IN} \times V_{OUT}}$	I _{OUT} =40mA, 2.8V≤V _{IN} ≤8.0V		0.2	0.5	%/V
Output Voltage Temperature Characteristics	$\frac{\Delta V_{OUT}}{\Delta T_{OPR} \times V_{OUT}}$	I _{OUT} =40mA		±100		ppm/°C

■ ELECTRICAL CHARACTERISTICS(Cont.)

For LR1106-22

PARAMETER	SYMBOL	TEST CONDITIONS	MIN	TYP	MAX	UNIT
Output Voltage	V_{OUT}	$V_{IN}=3.2V, I_{OUT}=40mA$	2.156	2.200	2.244	V
Input Voltage	V_{IN}				8	V
Load Regulation	ΔV_{OUT}	$V_{IN}=3.2V, 1mA \leq I_{OUT} \leq 200mA$		40	100	mV
Dropout Voltage	V_{D1}	$I_{OUT}=100mA$		200	300	mV
	V_{D2}	$I_{OUT}=200mA$		400	600	
Maximum Output Current	$I_{OUT(MAX)}$	$V_{IN}=3.2V, V_{OUT} \geq V_{OUT} \times 0.90$	400			mA
Supply Current	I_{SS}	$V_{IN}=3.2V, V_{EN}=V_{IN}$		30.0	50.0	μA
EN Input Bias Current	I_{EH}	$V_{EN}=V_{IN}$			0.1	μA
	I_{EL}	$V_{EN}=0, V_{IN}=3.2V \text{ to } 8V$		1.0	3.0	μA
EN Input Threshold	V_{EH}	$V_{IN}=3.2V \text{ to } 8V$	$V_{IN}/2+0.8$		V_{IN}	V
	V_{EL}	$V_{IN}=3.2V \text{ to } 8V$	0		0.4	V
Line Regulation	$\frac{\Delta V_{OUT}}{\Delta V_{IN} \times V_{OUT}}$	$I_{OUT}=40mA, 3.2V \leq V_{IN} \leq 8.0V$		0.2	0.5	%/V
Output Voltage Temperature Characteristics	$\frac{\Delta V_{OUT}}{\Delta T_{OPR} \times V_{OUT}}$	$I_{OUT}=40mA$		± 100		ppm/ $^{\circ}C$

For LR1106-25

PARAMETER	SYMBOL	TEST CONDITIONS	MIN	TYP	MAX	UNIT
Output Voltage	V_{OUT}	$V_{IN}=3.5V, I_{OUT}=40mA$	2.450	2.500	2.550	V
Input Voltage	V_{IN}				8	V
Load Regulation	ΔV_{OUT}	$V_{IN}=3.5V, 1mA \leq I_{OUT} \leq 200mA$		40	100	mV
Dropout Voltage	V_{D1}	$I_{OUT}=100mA$		170	250	mV
	V_{D2}	$I_{OUT}=200mA$		320	500	
Maximum Output Current	$I_{OUT(MAX)}$	$V_{IN}=3.5V, V_{OUT} \geq V_{OUT} \times 0.93$	400			mA
Supply Current	I_{SS}	$V_{IN}=3.5V, V_{EN}=V_{IN}$		30.0	50.0	μA
EN Input Bias Current	I_{EH}	$V_{EN}=V_{IN}$			0.1	μA
	I_{EL}	$V_{EN}=0, V_{IN}=3.5V \text{ to } 8V$		1.0	3.0	μA
EN Input Threshold	V_{EH}	$V_{IN}=3.5V \text{ to } 8V$	$V_{IN}/2+0.8$		V_{IN}	V
	V_{EL}	$V_{IN}=3.5V \text{ to } 8V$	0		0.4	V
Line Regulation	$\frac{\Delta V_{OUT}}{\Delta V_{IN} \times V_{OUT}}$	$I_{OUT}=40mA, 3.5V \leq V_{IN} \leq 8.0V$		0.2	0.5	%/V
Output Voltage Temperature Characteristics	$\frac{\Delta V_{OUT}}{\Delta T_{OPR} \times V_{OUT}}$	$I_{OUT}=40mA$		± 100		ppm/ $^{\circ}C$

For LR1106-27

PARAMETER	SYMBOL	TEST CONDITIONS	MIN	TYP	MAX	UNIT
Output Voltage	V_{OUT}	$V_{IN}=3.7V, I_{OUT}=40mA$	2.646	2.700	2.754	V
Input Voltage	V_{IN}				8	V
Load Regulation	ΔV_{OUT}	$V_{IN}=3.7V, 1mA \leq I_{OUT} \leq 200mA$		40	100	mV
Dropout Voltage	V_{D1}	$I_{OUT}=100mA$		170	250	mV
	V_{D2}	$I_{OUT}=200mA$		320	500	
Maximum Output Current	$I_{OUT(MAX)}$	$V_{IN}=3.7V, V_{OUT} \geq V_{OUT} \times 0.93$	400			mA
Supply Current	I_{SS}	$V_{IN}=3.7V, V_{EN}=V_{IN}$		30.0	50.0	μA
EN Input Bias Current	I_{EH}	$V_{EN}=V_{IN}$			0.1	μA
	I_{EL}	$V_{EN}=0, V_{IN}=3.7V \text{ to } 8V$		1.0	3.0	μA
EN Input Threshold	V_{EH}	$V_{IN}=3.7V \text{ to } 8V$	$V_{IN}/2+0.8$		V_{IN}	V
	V_{EL}	$V_{IN}=3.7V \text{ to } 8V$	0		0.4	V
Line Regulation	$\frac{\Delta V_{OUT}}{\Delta V_{IN} \times V_{OUT}}$	$I_{OUT}=40mA, 3.7V \leq V_{IN} \leq 8.0V$		0.2	0.5	%/V
Output Voltage Temperature Characteristics	$\frac{\Delta V_{OUT}}{\Delta T_{OPR} \times V_{OUT}}$	$I_{OUT}=40mA$		± 100		ppm/ $^{\circ}C$

■ ELECTRICAL CHARACTERISTICS(Cont.)

For LR1106-28

PARAMETER	SYMBOL	TEST CONDITIONS	MIN	TYP	MAX	UNIT
Output Voltage	V_{OUT}	$V_{IN}=3.8V, I_{OUT}=40mA$	2.744	2.800	2.856	V
Input Voltage	V_{IN}				8	V
Load Regulation	ΔV_{OUT}	$V_{IN}=3.8V, 1mA \leq I_{OUT} \leq 200mA$		40	100	mV
Dropout Voltage	V_{D1}	$I_{OUT}=100mA$		170	250	mV
	V_{D2}	$I_{OUT}=200mA$		320	500	
Maximum Output Current	$I_{OUT(MAX)}$	$V_{IN}=3.8V, V_{OUT} \geq V_{OUT} \times 0.93$	400			mA
Supply Current	I_{SS}	$V_{IN}=3.8V, V_{EN}=V_{IN}$		30.0	50.0	μA
EN Input Bias Current	I_{EH}	$V_{EN}=V_{IN}$			0.1	μA
	I_{EL}	$V_{EN}=0, V_{IN}=3.8V \text{ to } 8V$		1.0	3.0	μA
EN Input Threshold	V_{EH}	$V_{IN}=3.8V \text{ to } 8V$	$V_{IN}/2+0.8$		V_{IN}	V
	V_{EL}	$V_{IN}=3.8V \text{ to } 8V$	0		0.4	V
Line Regulation	$\frac{\Delta V_{OUT}}{\Delta V_{IN} \times V_{OUT}}$	$I_{OUT}=40mA, 3.8V \leq V_{IN} \leq 8.0V$		0.2	0.5	%/V
Output Voltage Temperature Characteristics	$\frac{\Delta V_{OUT}}{\Delta T_{OPR} \times V_{OUT}}$	$I_{OUT}=40mA$		± 100		ppm/ $^{\circ}C$

For LR1106-2J(2.85V)

PARAMETER	SYMBOL	TEST CONDITIONS	MIN	TYP	MAX	UNIT
Output Voltage	V_{OUT}	$V_{IN}=3.85V, I_{OUT}=40mA$	2.793	2.850	2.907	V
Input Voltage	V_{IN}				8	V
Load Regulation	ΔV_{OUT}	$V_{IN}=3.85V, 1mA \leq I_{OUT} \leq 200mA$		40	100	mV
Dropout Voltage	V_{D1}	$I_{OUT}=100mA$		170	250	mV
	V_{D2}	$I_{OUT}=200mA$		250	500	
Maximum Output Current	$I_{OUT(MAX)}$	$V_{IN}=3.85V, V_{OUT} \geq V_{OUT} \times 0.93$	400			mA
Supply Current	I_{SS}	$V_{IN}=3.85V, V_{EN}=V_{IN}$		30.0	50.0	μA
EN Input Bias Current	I_{EH}	$V_{EN}=V_{IN}$			0.1	μA
	I_{EL}	$V_{EN}=0, V_{IN}=3.85 \text{ to } 8V$		1.0	3.0	μA
EN Input Threshold	V_{EH}	$V_{IN}=3.85V \text{ to } 8V$	$V_{IN}/2+0.8$		V_{IN}	V
	V_{EL}	$V_{IN}=3.85V \text{ to } 8V$	0		0.4	V
Line Regulation	$\frac{\Delta V_{OUT}}{\Delta V_{IN} \times V_{OUT}}$	$I_{OUT}=40mA, 3.85V \leq V_{IN} \leq 8.0V$		0.2	0.5	%/V
Output Voltage Temperature Characteristics	$\frac{\Delta V_{OUT}}{\Delta T_{OPR} \times V_{OUT}}$	$I_{OUT}=40mA$		± 100		ppm/ $^{\circ}C$

For LR1106-30

PARAMETER	SYMBOL	TEST CONDITIONS	MIN	TYP	MAX	UNIT
Output Voltage	V_{OUT}	$V_{IN}=4.0V, I_{OUT}=40mA$	2.940	3.000	3.060	V
Input Voltage	V_{IN}				8	V
Load Regulation	ΔV_{OUT}	$V_{IN}=4.0V, 1mA \leq I_{OUT} \leq 200mA$		40	100	mV
Dropout Voltage	V_{D1}	$I_{OUT}=100mA$		150	220	mV
	V_{D2}	$I_{OUT}=200mA$		300	420	
Maximum Output Current	$I_{OUT(MAX)}$	$V_{IN}=4.0V, V_{OUT} \geq V_{OUT} \times 0.96$	400			mA
Supply Current	I_{SS}	$V_{IN}=4.0V, V_{EN}=V_{IN}$		30.0	50.0	μA
EN Input Bias Current	I_{EH}	$V_{EN}=V_{IN}$			0.1	μA
	I_{EL}	$V_{EN}=0, V_{IN}=4.0V \text{ to } 8V$		1.0	3.0	μA
EN Input Threshold	V_{EH}	$V_{IN}=4.0V \text{ to } 8V$	$V_{IN}/2+0.8$		V_{IN}	V
	V_{EL}	$V_{IN}=4.0V \text{ to } 8V$	0		0.4	V
Line Regulation	$\frac{\Delta V_{OUT}}{\Delta V_{IN} \times V_{OUT}}$	$I_{OUT}=40mA, 4V \leq V_{IN} \leq 8.0V$		0.2	0.5	%/V
Output Voltage Temperature Characteristics	$\frac{\Delta V_{OUT}}{\Delta T_{OPR} \times V_{OUT}}$	$I_{OUT}=40mA$		± 100		ppm/ $^{\circ}C$

■ ELECTRICAL CHARACTERISTICS(Cont.)

For LR1106-31

PARAMETER	SYMBOL	TEST CONDITIONS	MIN	TYP	MAX	UNIT
Output Voltage	V_{OUT}	$V_{IN}=4.1V, I_{OUT}=40mA$	3.038	3.100	3.162	V
Input Voltage	V_{IN}				8	V
Load Regulation	ΔV_{OUT}	$V_{IN}=4.1V, 1mA \leq I_{OUT} \leq 200mA$		40	100	mV
Dropout Voltage	V_{D1}	$I_{OUT}=100mA$		150	220	mV
	V_{D2}	$I_{OUT}=200mA$		300	420	
Maximum Output Current	$I_{OUT(MAX)}$	$V_{IN}=4.1V, V_{OUT} \geq V_{OUT} \times 0.96$	400			mA
Supply Current	I_{SS}	$V_{IN}=4.1V, V_{EN}=V_{IN}$		30.0	50.0	μA
EN Input Bias Current	I_{EH}	$V_{EN}=V_{IN}$			0.1	μA
	I_{EL}	$V_{EN}=0, V_{IN}=4.1V \text{ to } 8V$		1.0	3.0	μA
EN Input Threshold	V_{EH}	$V_{IN}=4.1V \text{ to } 8V$	$V_{IN}/2+0.8$		V_{IN}	V
	V_{EL}	$V_{IN}=4.1V \text{ to } 8V$	0		0.4	V
Line Regulation	$\frac{\Delta V_{OUT}}{\Delta V_{IN} \times V_{OUT}}$	$I_{OUT}=40mA, 4V \leq V_{IN} \leq 8.0V$		0.2	0.5	%/V
Output Voltage Temperature Characteristics	$\frac{\Delta V_{OUT}}{\Delta T_{OPR} \times V_{OUT}}$	$I_{OUT}=40mA$		± 100		ppm/ $^{\circ}C$

For LR1106-33

PARAMETER	SYMBOL	TEST CONDITIONS	MIN	TYP	MAX	UNIT
Output Voltage	V_{OUT}	$V_{IN}=4.3V, I_{OUT}=40mA$	3.234	3.300	3.366	V
Input Voltage	V_{IN}				8	V
Load Regulation	ΔV_{OUT}	$V_{IN}=4.3V, 1mA \leq I_{OUT} \leq 200mA$		40	100	mV
Dropout Voltage	V_{D1}	$I_{OUT}=100mA$		150	220	mV
	V_{D2}	$I_{OUT}=200mA$		300	420	
Maximum Output Current	$I_{OUT(MAX)}$	$V_{IN}=4.3V, V_{OUT} \geq V_{OUT} \times 0.96$	400			mA
Supply Current	I_{SS}	$V_{IN}=4.3V, V_{EN}=V_{IN}$		30.0	50.0	μA
EN Input Bias Current	I_{EH}	$V_{EN}=V_{IN}$			0.1	μA
	I_{EL}	$V_{EN}=0, V_{IN}=4.3V \text{ to } 8V$		1.0	3.0	μA
EN Input Threshold	V_{EH}	$V_{IN}=4.3V \text{ to } 8V$	$V_{IN}/2+0.8$		V_{IN}	V
	V_{EL}	$V_{IN}=4.3V \text{ to } 8V$	0		0.4	V
Line Regulation	$\frac{\Delta V_{OUT}}{\Delta V_{IN} \times V_{OUT}}$	$I_{OUT}=40mA, 4.3V \leq V_{IN} \leq 8.0V$		0.2	0.5	%/V
Output Voltage Temperature Characteristics	$\frac{\Delta V_{OUT}}{\Delta T_{OPR} \times V_{OUT}}$	$I_{OUT}=40mA$		± 100		ppm/ $^{\circ}C$

For LR1106-50

PARAMETER	SYMBOL	TEST CONDITIONS	MIN	TYP	MAX	UNIT
Output Voltage	V_{OUT}	$V_{IN}=6.0V, I_{OUT}=40mA$	4.900	5.000	5.100	V
Input Voltage	V_{IN}				8	V
Load Regulation	ΔV_{OUT}	$V_{IN}=6.0V, 1mA \leq I_{OUT} \leq 200mA$		40	100	mV
Dropout Voltage	V_{D1}	$I_{OUT}=100mA$		100	180	mV
	V_{D2}	$I_{OUT}=200mA$		200	320	
Maximum Output Current	$I_{OUT(MAX)}$	$V_{IN}=6.0V, V_{OUT} \geq V_{OUT} \times 0.96$	400			mA
Supply Current	I_{SS}	$V_{IN}=6.0V, V_{EN}=V_{IN}$		30.0	50.0	μA
EN Input Bias Current	I_{EH}	$V_{EN}=V_{IN}$			0.1	μA
	I_{EL}	$V_{EN}=0, V_{IN}=6.0V \text{ to } 8V$		1.0	3.0	μA
EN Input Threshold	V_{EH}	$V_{IN}=6.0V \text{ to } 8V$	$V_{IN}/2+0.8$		V_{IN}	V
	V_{EL}	$V_{IN}=6.0V \text{ to } 8V$	0		0.4	V
Line Regulation	$\frac{\Delta V_{OUT}}{\Delta V_{IN} \times V_{OUT}}$	$I_{OUT}=40mA, 6.0V \leq V_{IN} \leq 8.0V$		0.2	0.5	%/V
Output Voltage Temperature Characteristics	$\frac{\Delta V_{OUT}}{\Delta T_{OPR} \times V_{OUT}}$	$I_{OUT}=40mA$		± 100		ppm/ $^{\circ}C$

■ TYPICAL APPLICATION CIRCUIT

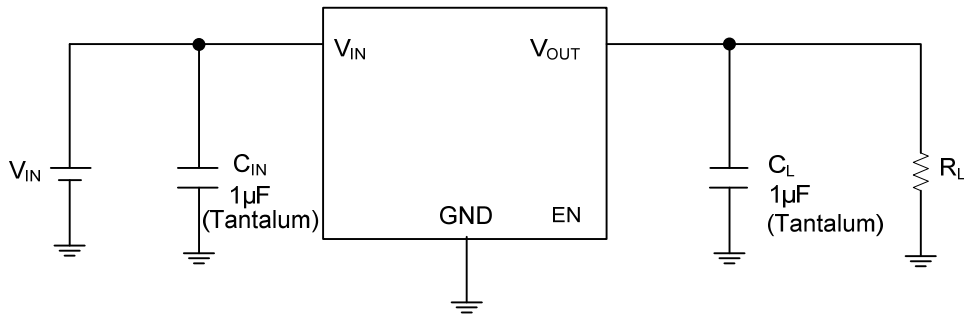

TYPICAL CHARACTERISTICS

(1) LR1106-18

Output Voltage vs. Output Current

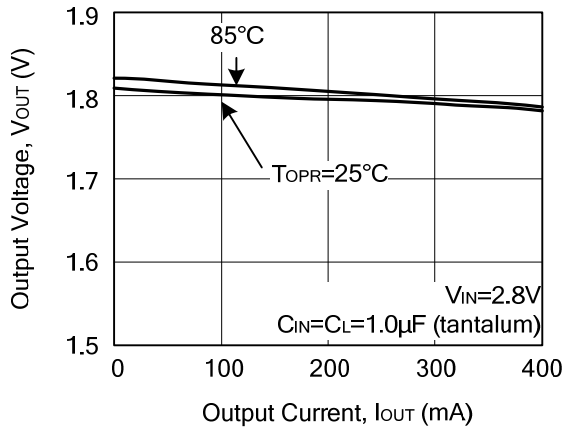

Output Voltage vs. Input Voltage

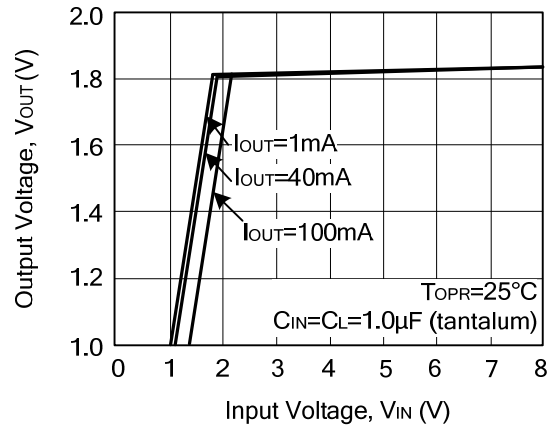

Dropout Voltage vs. Output Current

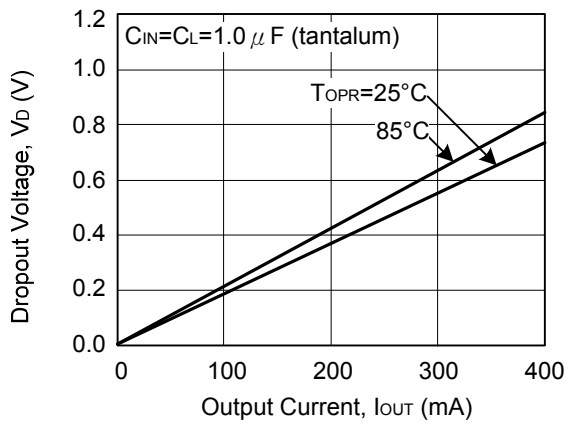

Supply Current vs. Input Voltage

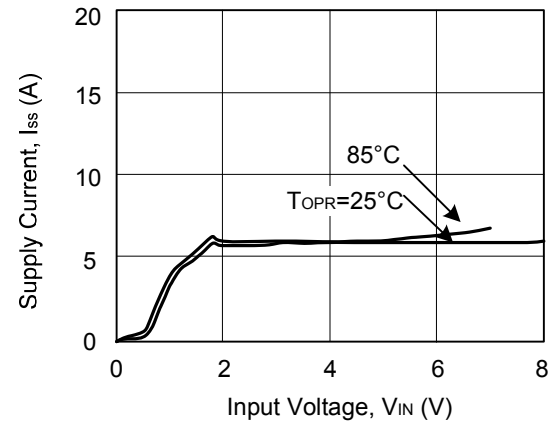

Output Voltage vs Ambient Temperature

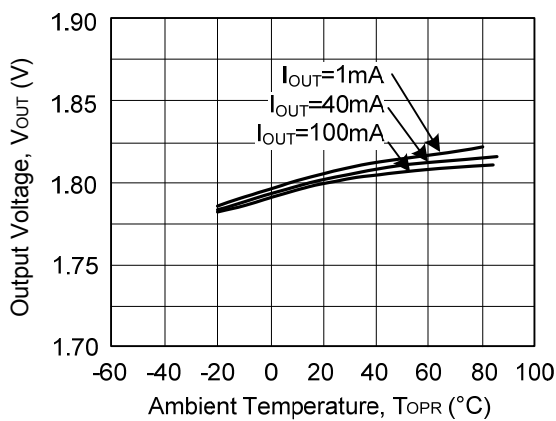

Supply Current vs Ambient Temperature

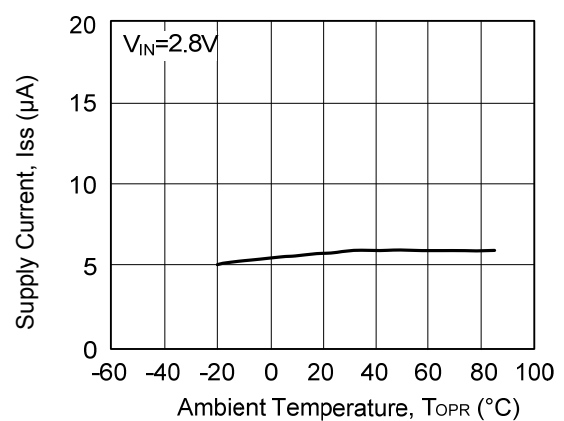

■ TYPICAL CHARACTERISTICS (Cont.)

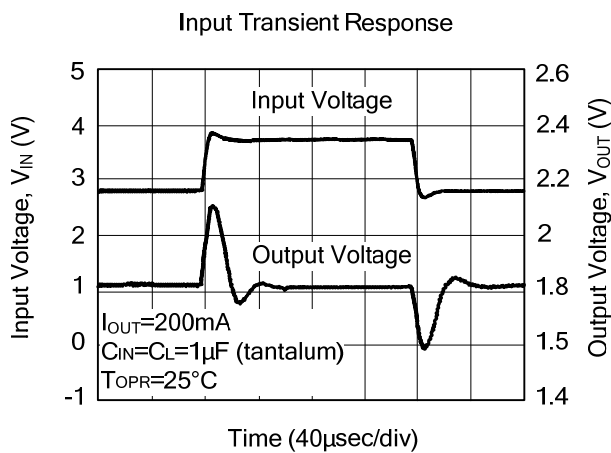
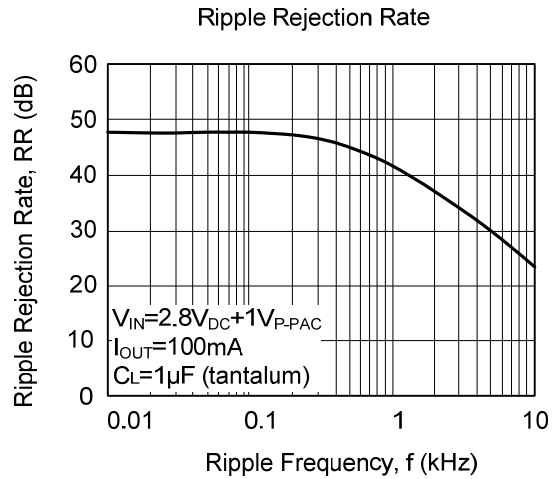
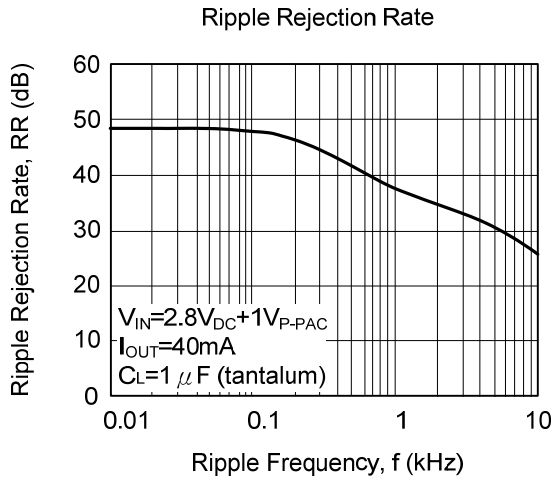
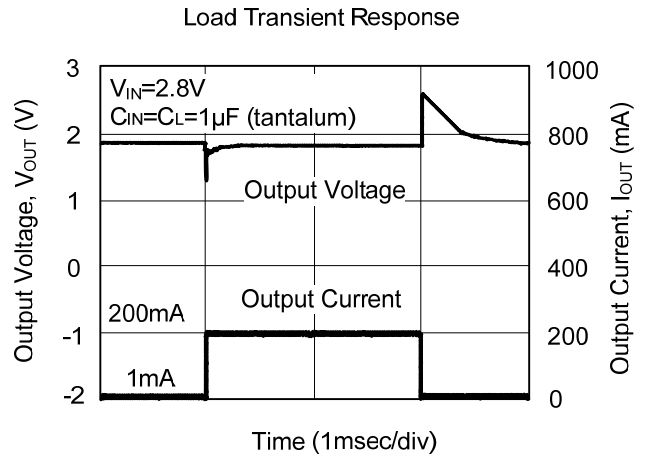
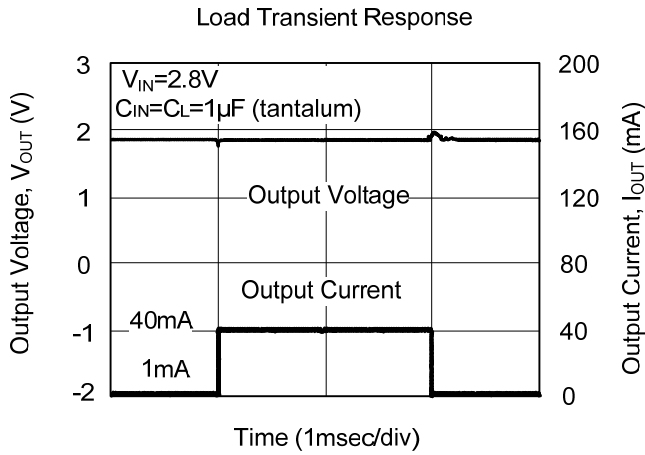

■ TYPICAL CHARACTERISTICS (Cont.)

(2) LR1106-25

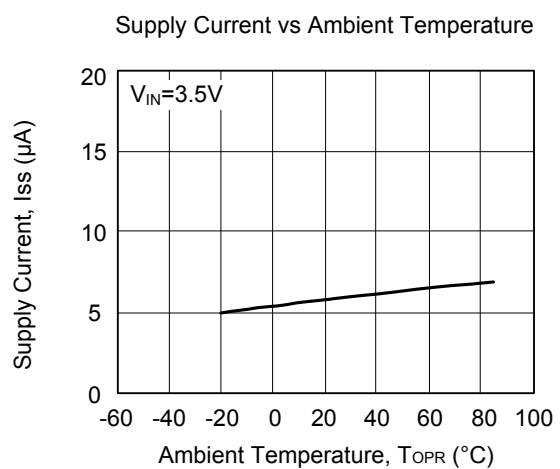
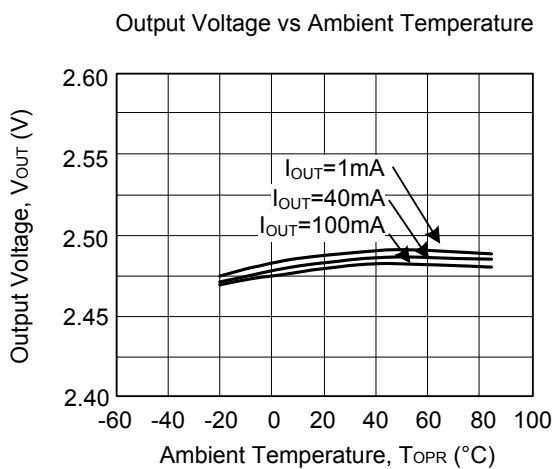
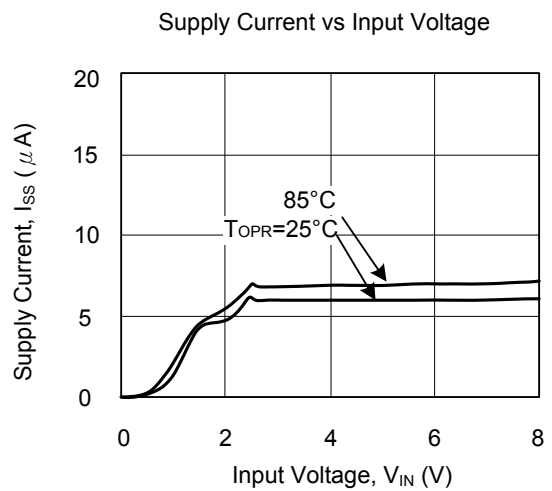
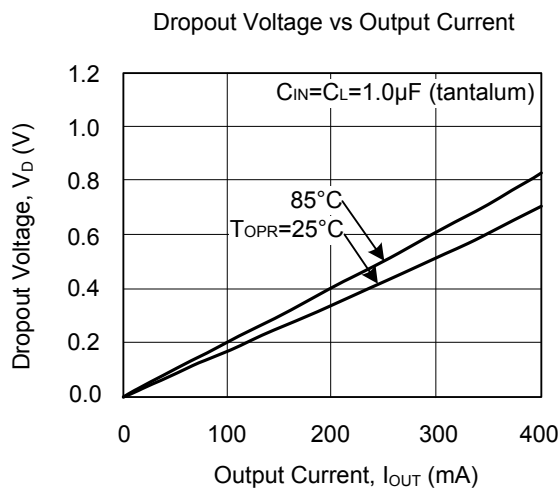
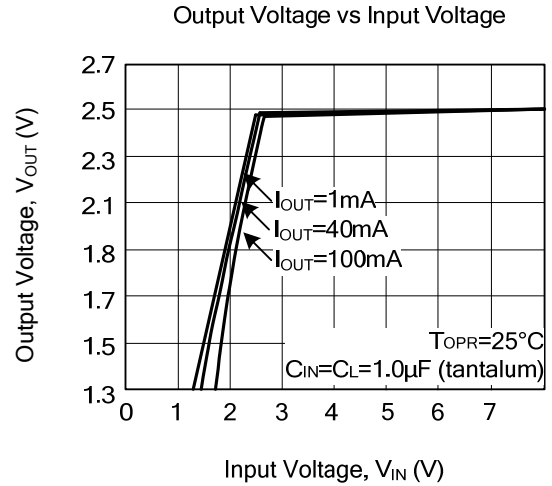
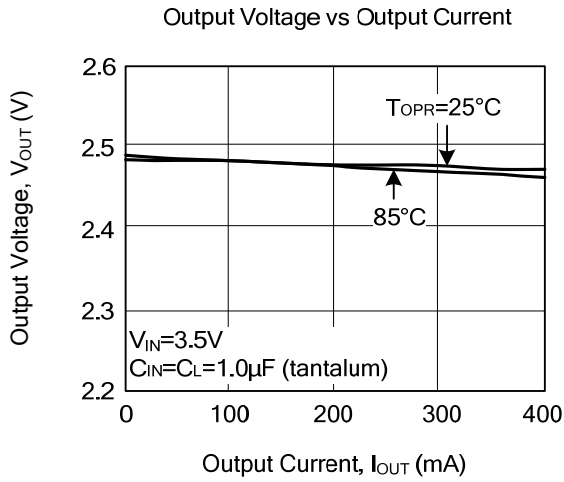

■ TYPICAL CHARACTERISTICS (Cont.)

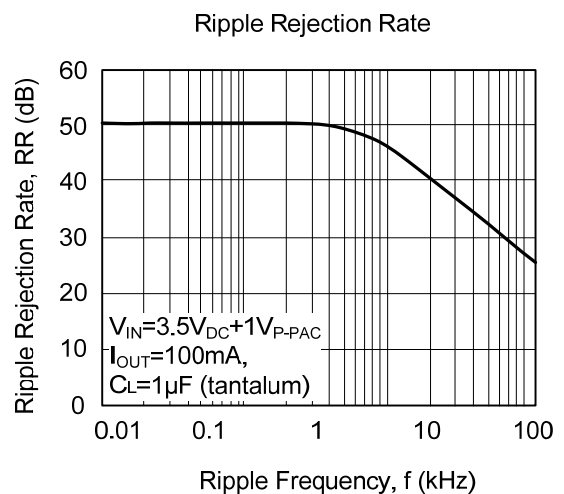
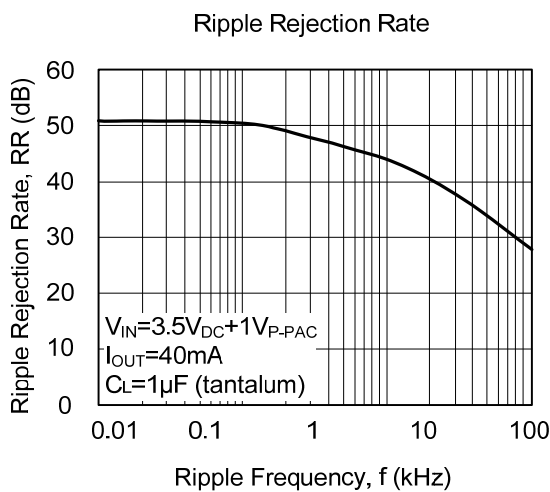
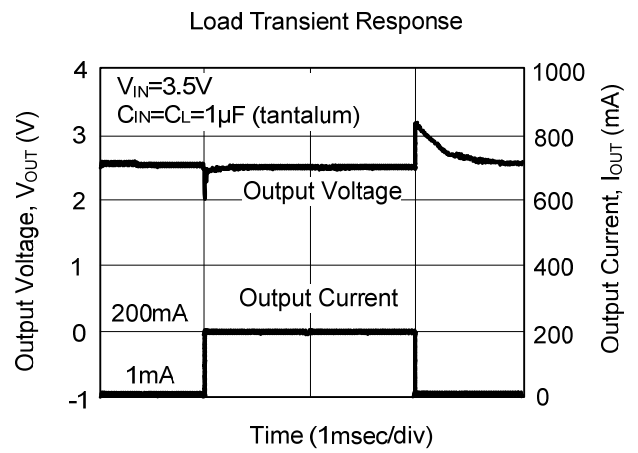
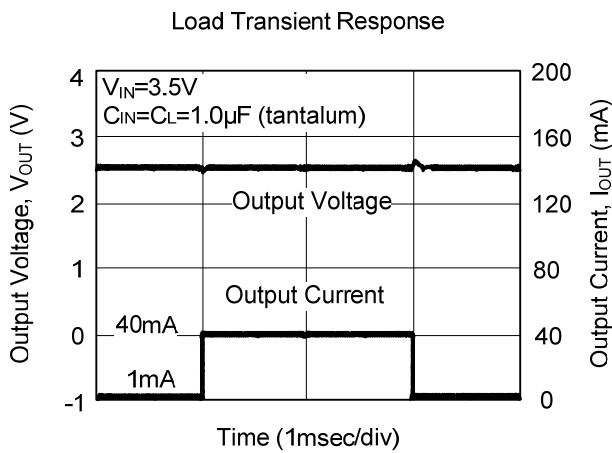
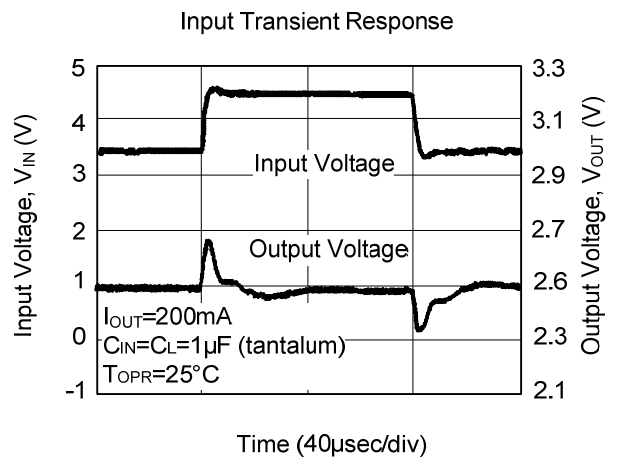
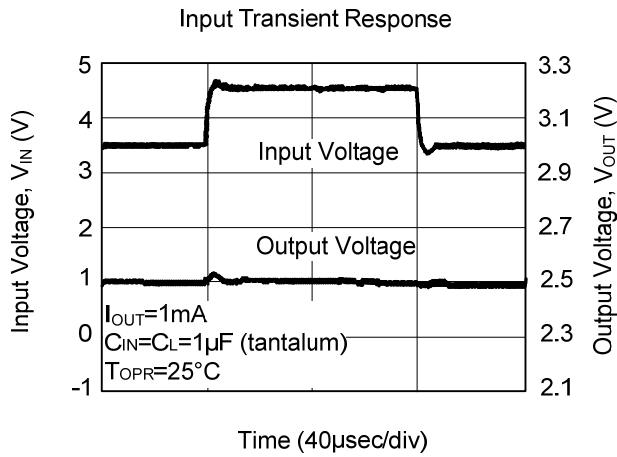

■ TYPICAL CHARACTERISTICS (Cont.)

(3) LR1106-33

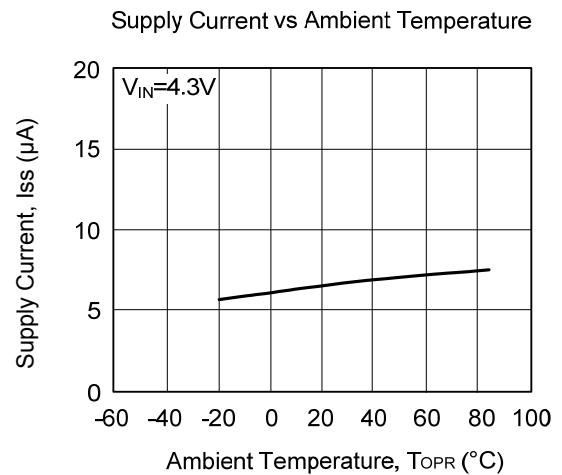
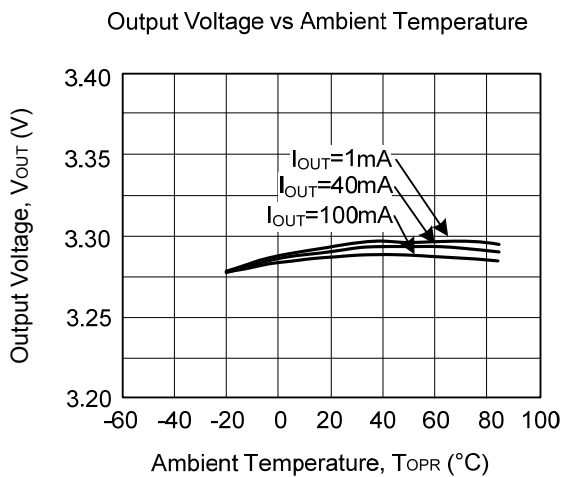
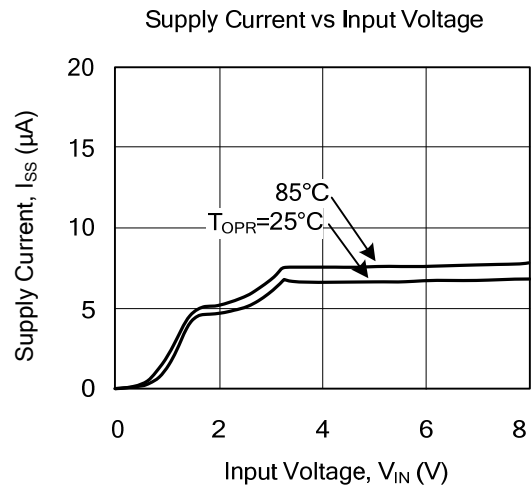
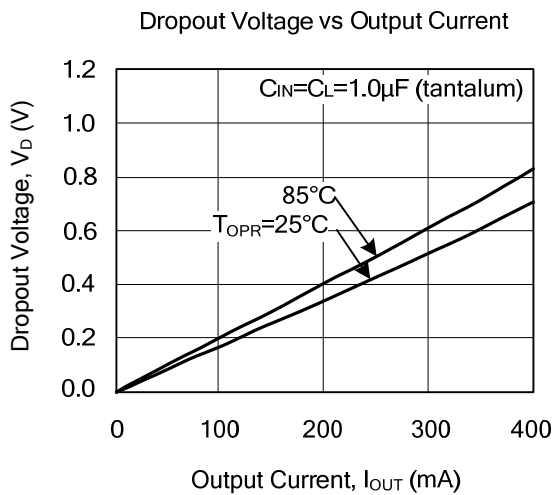
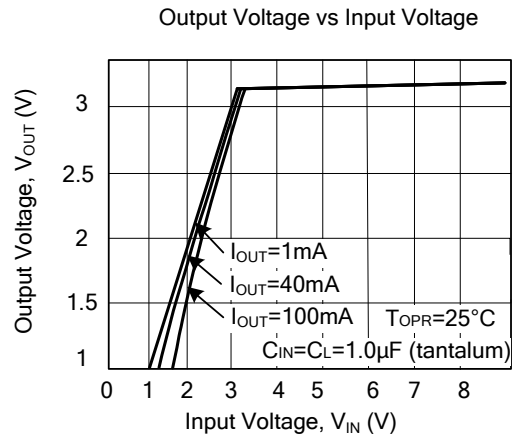
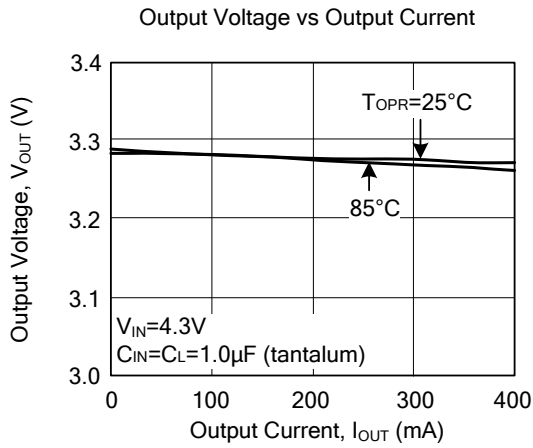

■ TYPICAL CHARACTERISTICS (Cont.)

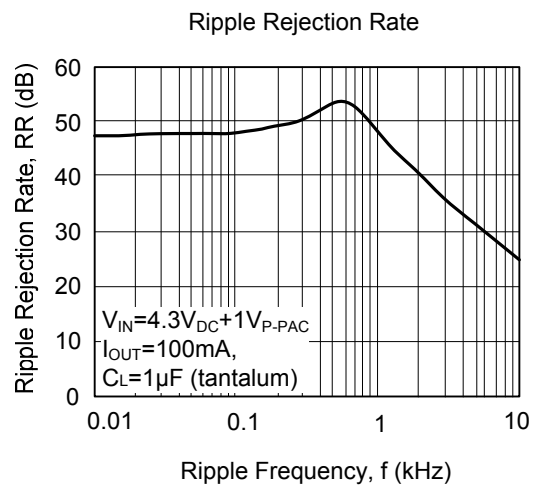
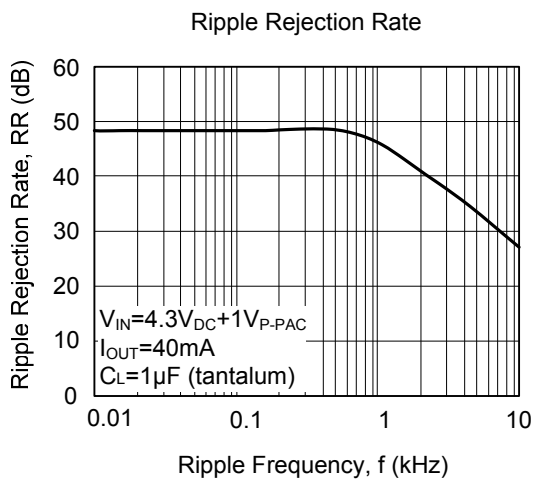
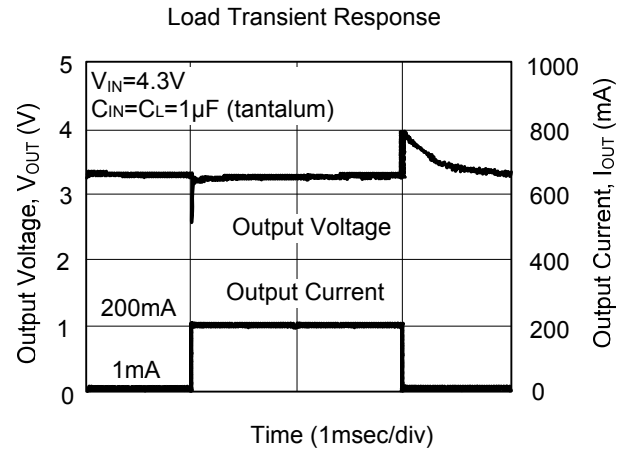
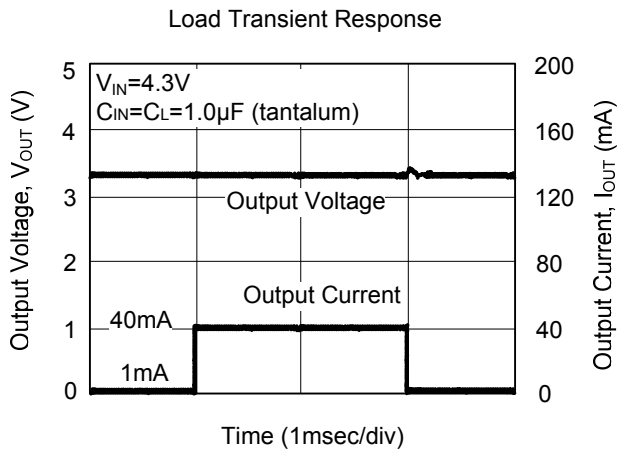
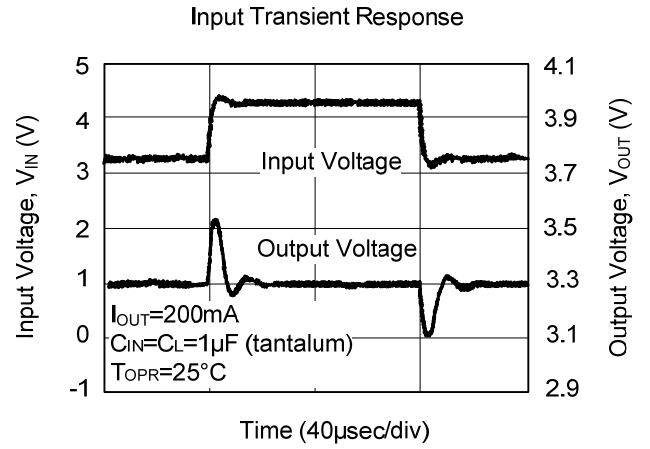
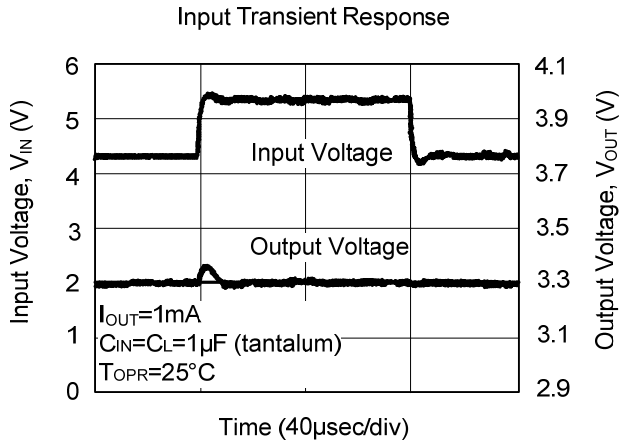

■ TYPICAL CHARACTERISTICS (Cont.)

(4) LR1106-50

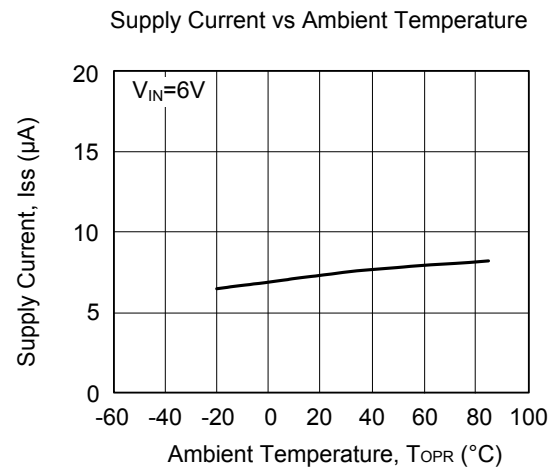
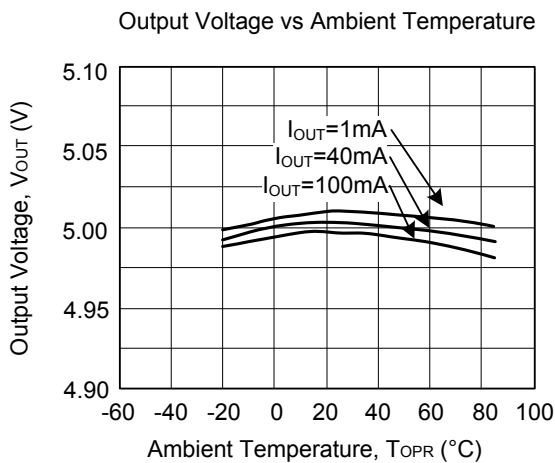
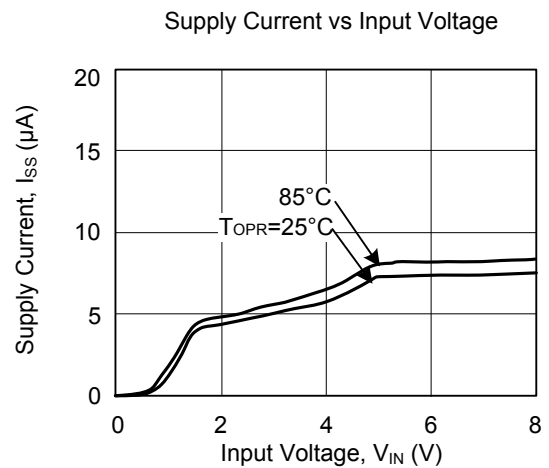
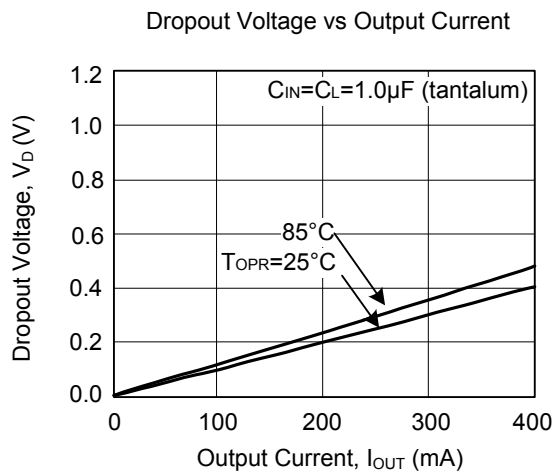
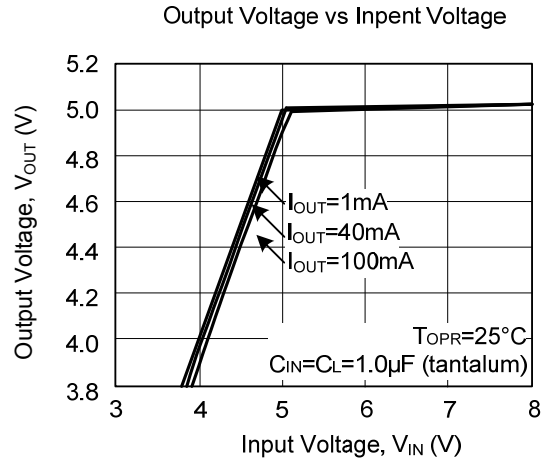
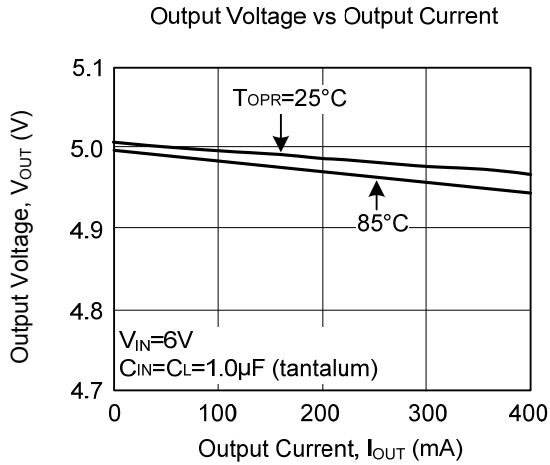

■ TYPICAL CHARACTERISTICS (Cont.)

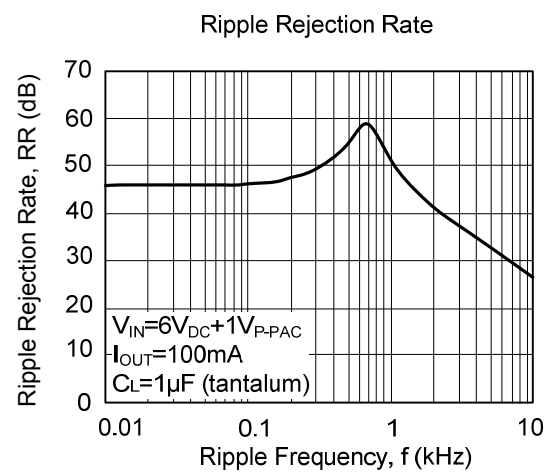
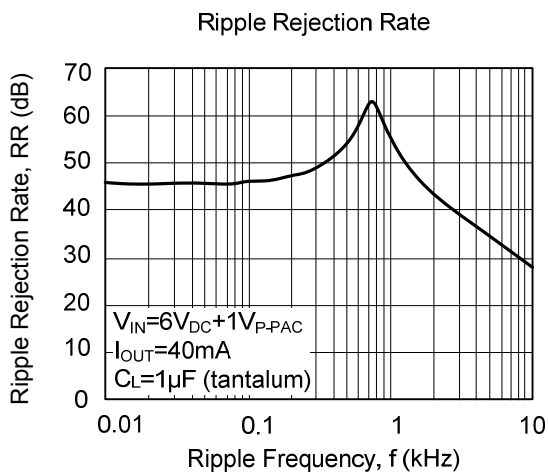
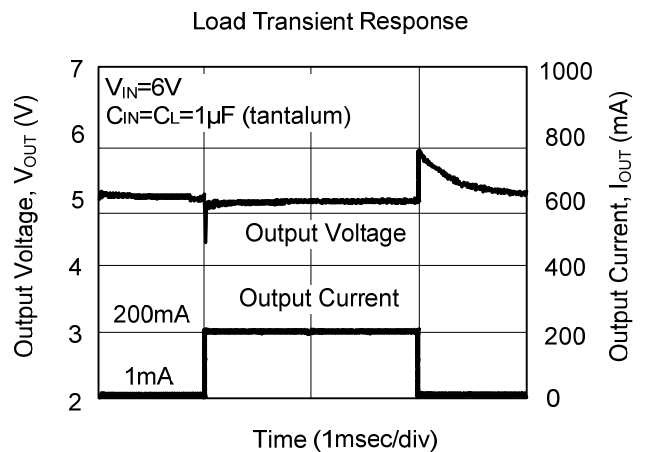
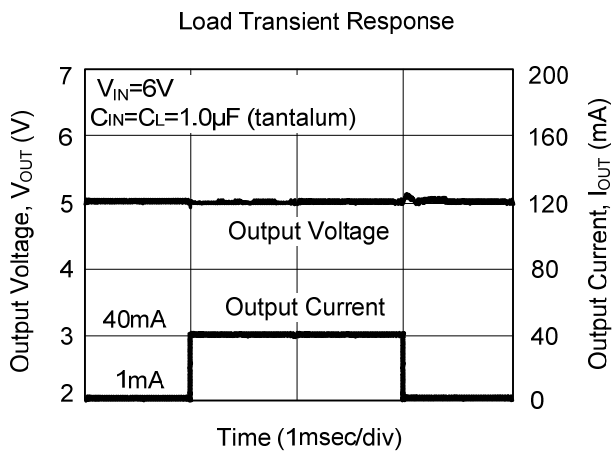
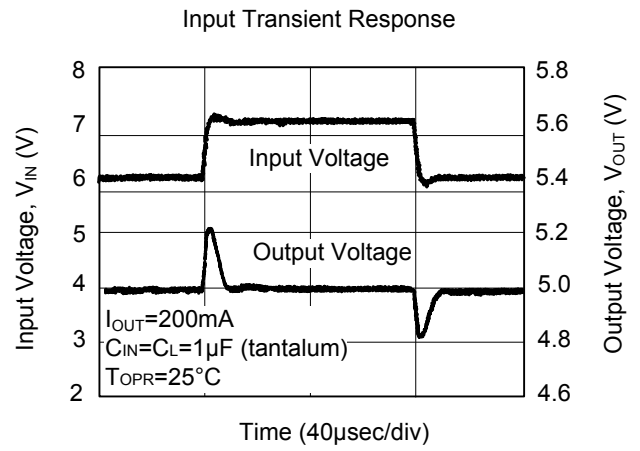
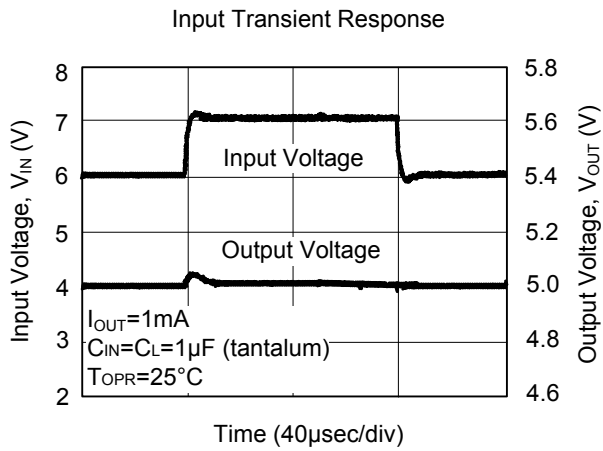

UTC assumes no responsibility for equipment failures that result from using products at values that exceed, even momentarily, rated values (such as maximum ratings, operating condition ranges, or other parameters) listed in products specifications of any and all UTC products described or contained herein. UTC products are not designed for use in life support appliances, devices or systems where malfunction of these products can be reasonably expected to result in personal injury. Reproduction in whole or in part is prohibited without the prior written consent of the copyright owner. The information presented in this document does not form part of any quotation or contract, is believed to be accurate and reliable and may be changed without notice.

X-ON Electronics

Largest Supplier of Electrical and Electronic Components

Click to view similar products for [Linear Voltage Regulators](#) category:

Click to view products by [Unisonic](#) manufacturer:

Other Similar products are found below :

[LV56831P-E](#) [LV5684PVD-XH](#) [MCDTSA6-2R](#) [L7815ACV-DG](#) [PQ3DZ53U](#) [LV56801P-E](#) [L78L05CZ/1SX](#) [L78LR05DL-MA-E](#) [636416C](#)
[714954EB](#) [LV5680P-E](#) [L78M15CV-DG](#) [L79M05T-E](#) [MIC5283-5.0YML-T5](#) [TLS202A1MBVHTSA1](#) [L78LR05D-MA-E](#) [NCV317MBTG](#)
[NTE7227](#) [MP2018GZD-33-P](#) [MP2018GZD-5-P](#) [LV5680NPVC-XH](#) [LT1054CN8](#) [MP2018GZD-5-Z](#) [MP2018GZD-33-Z](#) [CL9036A30F4M](#)
[CL9036A18F4M](#) [CL9036A25F4M](#) [CL9036A28F4M](#) [CL9036A33F4M](#) [CL9906A18F4N](#) [CL9906A30F4N](#) [CL9908A30F4M](#) [CL9908A33F4M](#)
[CL9908A18F4M](#) [CL9908A28F4M](#) [HXY6206I-3.0](#) [HXY6206I-3.3](#) [XC6206P252MR](#) [XC6206P282MR](#) [XC6206P302MR](#) [XC6206P332MR](#)
[CJ6211B12F](#) [LR8103B-T30](#) [LR6207A-T28](#) [LR8103B-T25](#) [LR8103A-T25](#) [LR8103A-T28](#) [LR8103B-T28](#) [LR8103A-T33](#) [LR8103B-T15](#)