



## LR18120

CMOS IC

### 2A LOW DROPOUT REGULATOR WITH ENABLE

#### DESCRIPTION

The UTC **LR18120** is a positive voltage regulator with high performance. It has low dropout voltage and low input voltage, besides its output voltage can be fixed at 1.0V, 1.2V, 1.5V, 1.8V, or 2.5V depending on internal feedback resistors or ADJ (not connected to the ground) with external feedback resistors. The input voltage of UTC **LR18120** can be low to 1.4V. There are two additional pin in the LR18120. One is EN pin and the other is POK pin.

The UTC **LR18120** is specially made for applications with low input voltage, low dropout voltage, and low output voltage which is almost the same as the input voltage. Typical applications include motherboards, notebooks, set top boxes, network cards and peripheral cards.

#### FEATURES

- \*  $V_{IN}$  as Low as 1.4V and  $V_{PP}$  Voltage 5V
- \*  $V_D=320mV @ I_{OUT}=2A, V_{OUT}=1.2V$
- \* Internal Over Current and Over Temperature Protection
- \* With Enable Pin
- \* Output Voltage:  $\pm 2\%$
- \* 1.0V, 1.2V, 1.5V, 1.8V and 2.5V Output Voltage Adjustable Externally Using Resistors
- \* When Disable  $V_{OUT}$  Pull Low Resistance

#### ORDERING INFORMATION

Ordering Number	Package	Packing
LR18120xG-xx-S08-R	SOP-8	Tape Reel
LR18120xG-xx-SH2-R	HSOP-8	Tape Reel

<p>LR18120xG-xx-S08-R</p> <ul style="list-style-type: none"> <li>(1) Packing Type</li> <li>(2) Package Type</li> <li>(3) Output Voltage Code</li> <li>(4) Green Package</li> <li>(5) Enable Threshold Level</li> </ul>	<ul style="list-style-type: none"> <li>(1) R: Tape Reel</li> <li>(2) S08: SOP-8, SH2: HSOP-8</li> <li>(3) xx: Refer to Marking Information</li> <li>(4) G: Halogen Free and Lead Free</li> <li>(5) H: High, L: Low</li> </ul>
--	---

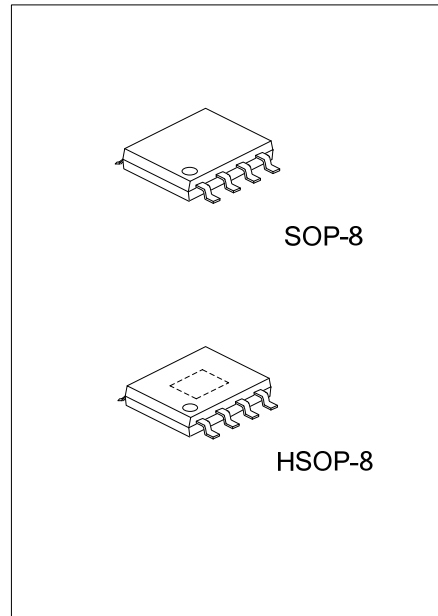

MARKING INFORMATION

PACKAGE	VOLTAGE CODE	MARKING
SOP-8 HSOP-8	10: 1.0V 12: 1.2V 15: 1.5V 18: 1.8V 25: 2.5V	

PIN CONFIGURATION

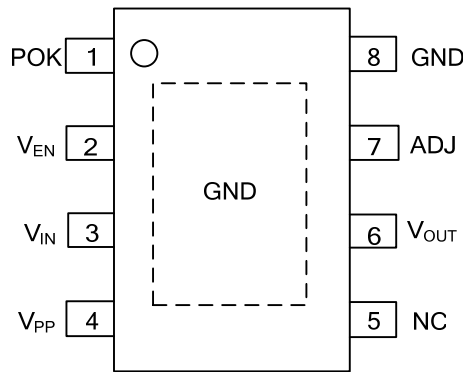

PIN DESCRIPTION

PIN NO.	PIN NAME	DESCRIPTION
1	POK	This pin will Indicate high under this situation: $V_O$ reaches 92% of its rating voltage. Open-drain output.
2	$V_{EN}$	The enable control Input pin. As while as this pin's voltage falls below 0.4V ,the LR18120 will stop working. When there's nothing connected with this pin, for active High version, the device will be enabled, for active Low version, the device will be shutdowned
3	$V_{IN}$	The pin of input voltage. Placing large capacitance closely to this pin is necessary. There should be connected a 10 $\mu$ F ceramic capacitor.
4	$V_{PP}$	This pin is for input voltage to control circuit.
5	NC	Connected nothing.
6	$V_{OUT}$	The voltage output pin.
7	ADJ	When this pin connected to the ground, $V_{OUT}$ will be set by the internal feedback resistors. Otherwise, if using external feedback resistors to decide the $V_{OUT}$ , $V_{OUT} = 0.8(R1+R2)/R2$ Volts.
8	GND	Ground.

■ BLOCK DIAGRAM

**Enable Threshold Level High:**

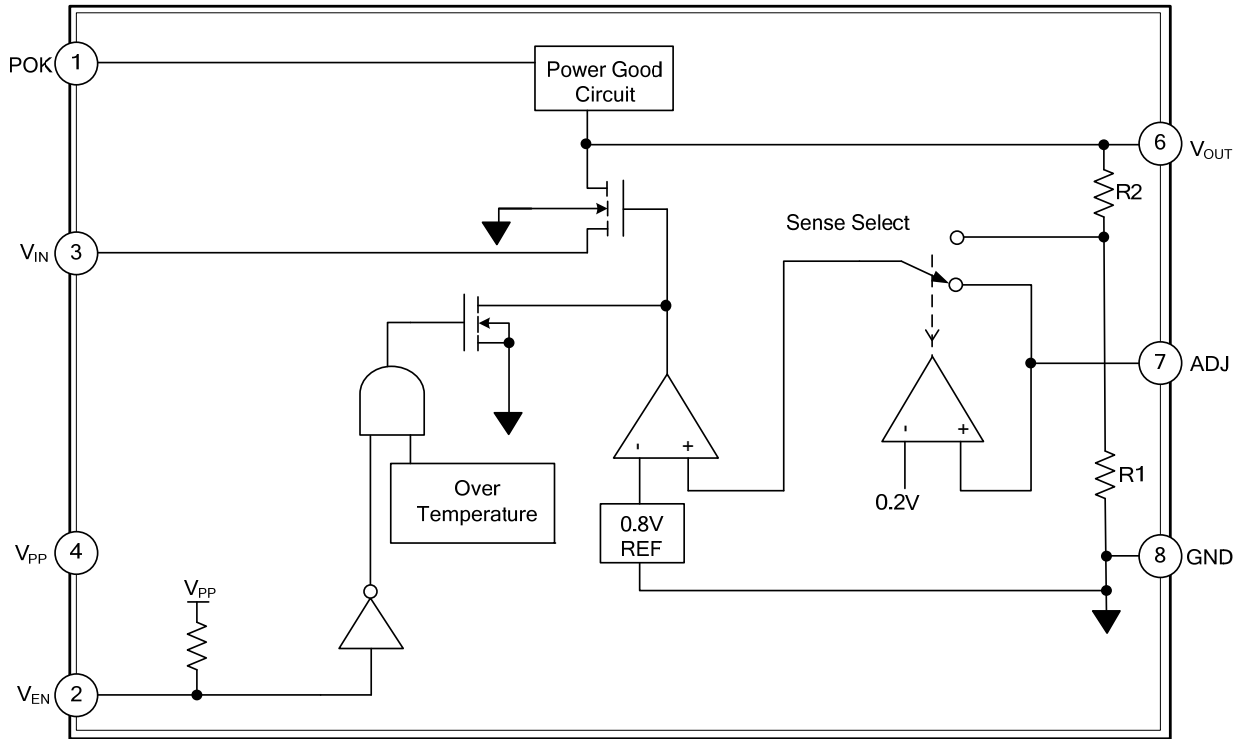

**Enable Threshold Level Low:**

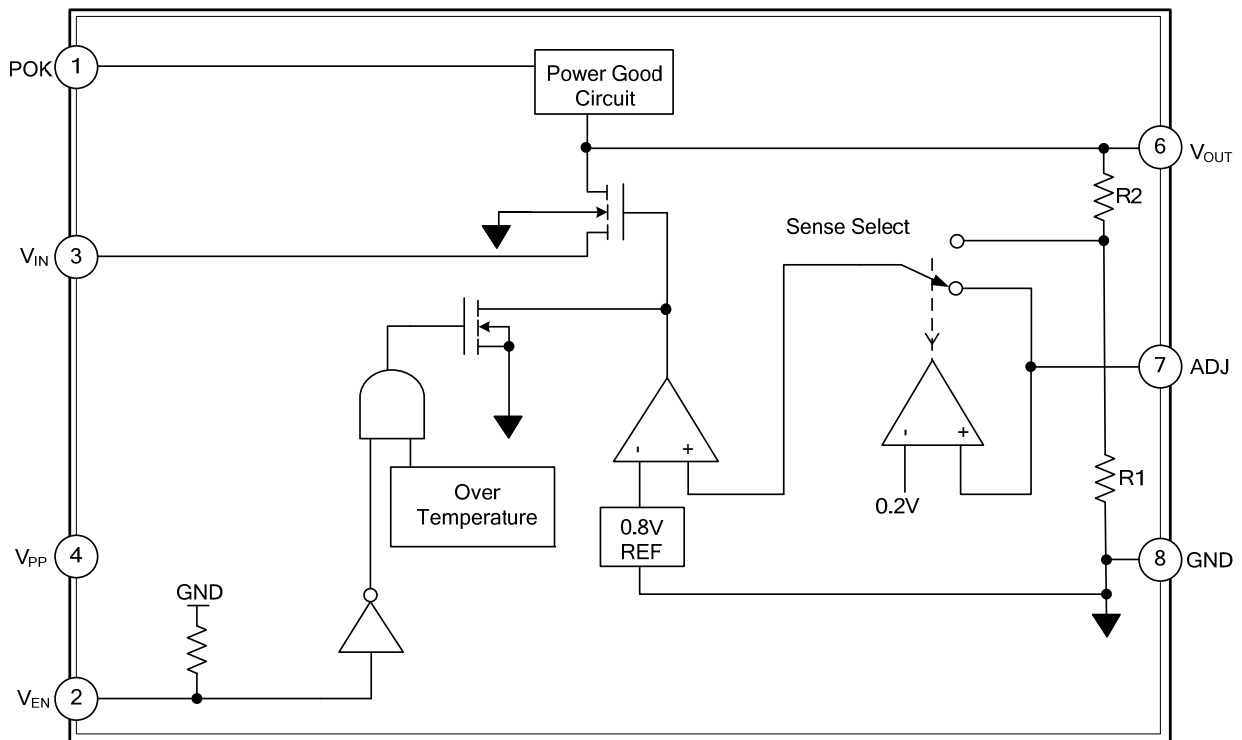

### ■ ABSOLUTE MAXIMUM RATING

PARAMETER	SYMBOL	RATINGS	UNIT
Input Voltage	$V_{PP}, V_{IN}$	7	V
Power Dissipation	$P_D$	Internally limited	
Junction Temperature	$T_J$	150	°C
Ambient Operation Temperature	$T_{OPR}$	-40~ +85	°C
Storage Temperature	$T_{STG}$	-65~ +150	°C
Note: Absolute maximum ratings are those values beyond which the device could be permanently damaged.			
Absolute maximum ratings are stress ratings only and functional device operation is not implied.			

### ■ RECOMMENDED OPERATING CONDITIONS

PARAMETER	SYMBOL	RATINGS	UNIT
$V_{IN}$ Voltage	$V_{IN}$	1.4 ~5.5	V
$V_{PP}$ Voltage	$V_{PP}$	4.5~5.5	V
Ambient Operation Temperature	$T_{OPR}$	-40°C ≤ $T_{OPR}$ ≤ +85°C	°C

### ■ THERMAL DATA

PARAMETER	SYMBOL	RATINGS	UNIT	
Junction to Ambient	SOP-8	$\theta_{JA}$	150	°C/W
	HSOP-8		143	°C/W
Junction to Case	SOP-8	$\theta_{JC}$	20	°C/W
	HSOP-8		14	°C/W

### ■ ELECTRICAL CHARACTERISTICS

$V_{PP}=5V$ ,  $V_{IN}=3.3V$ ,  $V_{EN}=V_{PP}$ ,  $I_{OUT}=10mA$ ,  $C_{IN}=10\mu F$ ,  $C_{OUT}=10\mu F$ ,  $T_A=T_J=25^\circ C$ , unless otherwise specified.

PARAMETER	SYMBOL	TEST CONDITIONS	MIN	TYP	MAX	UNIT
<b><math>V_{IN}</math></b>						
Input Voltage Range	$V_{IN}$		1.4		5.5	V
Quiescent Current (Ground Current)	$I_Q$	$V_{OUT}=2.5V$		1	2	mA
<b><math>V_{PP}</math></b>						
$V_{PP}$ Voltage Range	$V_{PP}$		4.5		5.5	V
$V_{PP}$ Current	$I_{PPH}$	$V_{OUT}=2.5V$		0.23	0.5	mA
	$I_{PPL}$	$V_{EN}=0V$		36	60	$\mu A$
<b><math>V_{OUT}</math></b>						
Output Voltage (Internal Fixed Voltage)	$V_{OUT}$	$V_{IN}=V_{OUT}+0.5V$ , $V_{OUT}=2.5V$	2.45	2.5	2.55	V
Line Regulation	$\frac{\Delta V_{OUT}}{\Delta V_{IN} \times V_{OUT}}$	$V_{IN}=(V_{OUT}+0.5V) \sim 5V$		0.2	1	%
Load Regulation	$\Delta V_{OUT}$	$10mA \leq I_{OUT} \leq 2A$		0.2	1	%
Dropout Voltage	$V_D$	$I_{OUT}=2A$		300	420	mV
Short Circuit Current				1.4		A
$V_{OUT}$ Pull Low Resistance		$V_{EN}=0V$		90		$\Omega$
<b>ADJ</b>						
Reference Voltage	$V_{REF}$	$V_{ADJ}=V_{OUT}$	0.788	0.8	0.812	V
Adjust Pin Current	$I_{ADJ}$			20	100	nA
Adjust Pin Threshold			0.15	0.2	0.25	V
<b><math>V_{EN}</math></b>						
$V_{EN}$ Pin Voltage High	$V_{H(EN)}$		1.6			V
$V_{EN}$ Pin Voltage Low	$V_{L(EN)}$				0.4	V
$V_{EN}$ Pin Bias Current	$I_{BIAS(EN)}$	$V_{EN}=0V$		12	40	$\mu A$
<b>POK</b>						
$V_{OUT}$ Power OK Voltage	$V_{THPOK}$			92		%
Hysteresis	$V_{HYPOK}$			7		%
<b>OVER TEMPERATURE PROTECTION</b>						
Over Temperature	$T_{OT}$			150		°C
Over Temperature Hysteresis	$T_{OTHY}$			30		°C

Note: Low duty pulse techniques are used during test to maintain junction temperature as close to ambient as possible.

## ■ TYPICAL APPLICATION CIRCUIT

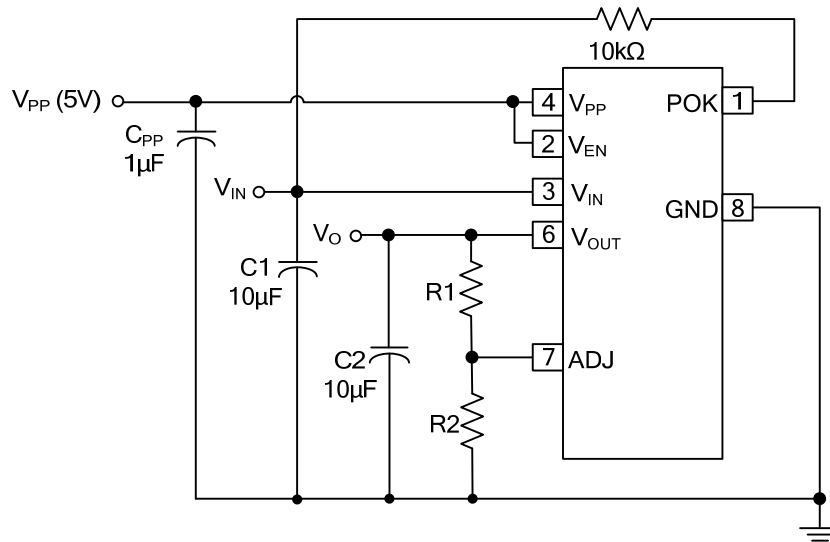

$$V_{OUT} = \frac{0.8(R1 + R2)}{R2} \text{ Volts}$$

$R2 < 120k\Omega$  is recommended

■ TYPICAL CHARACTERISTICS ( $V_{CC}=3.3V$ ,  $T_A=25^\circ C$ , unless otherwise specified.)

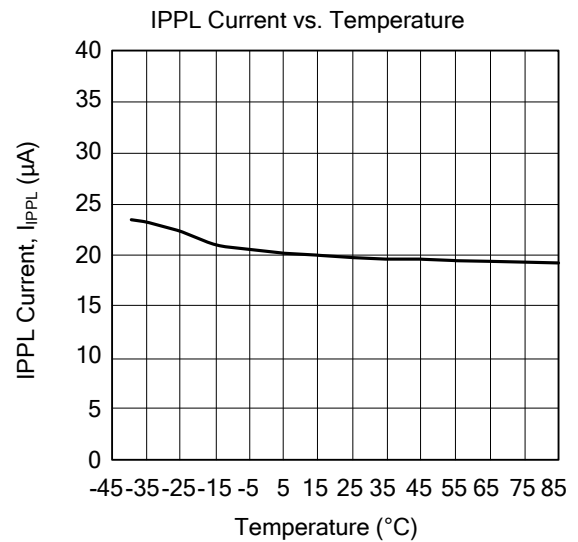
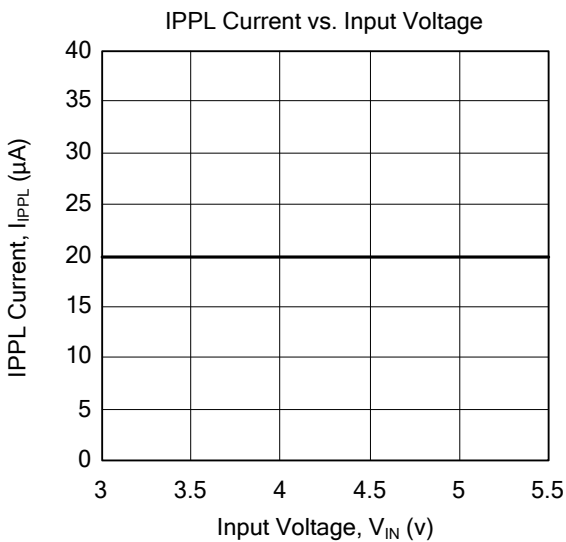
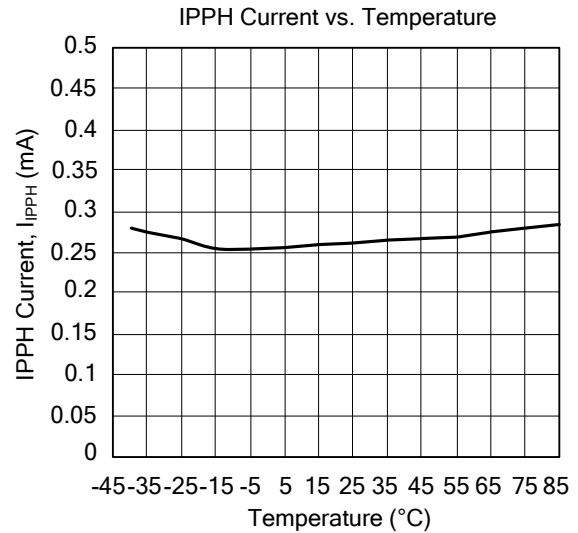
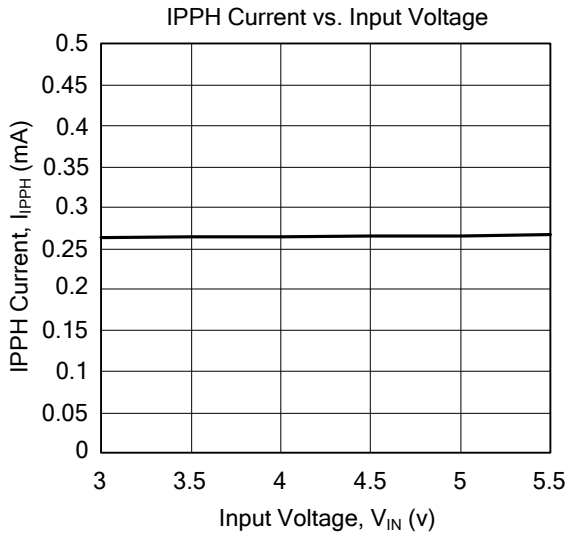
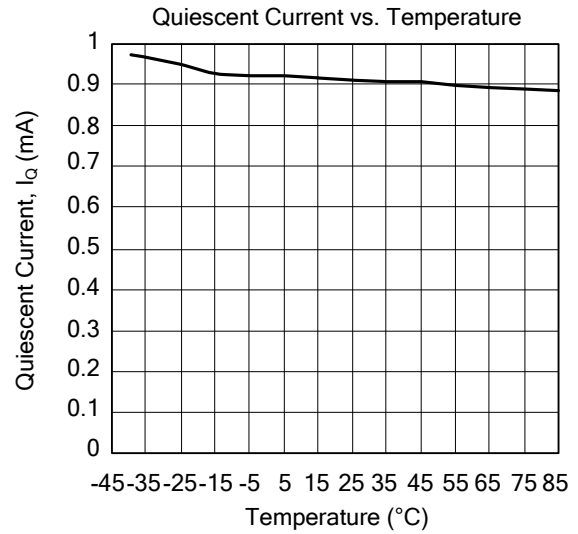
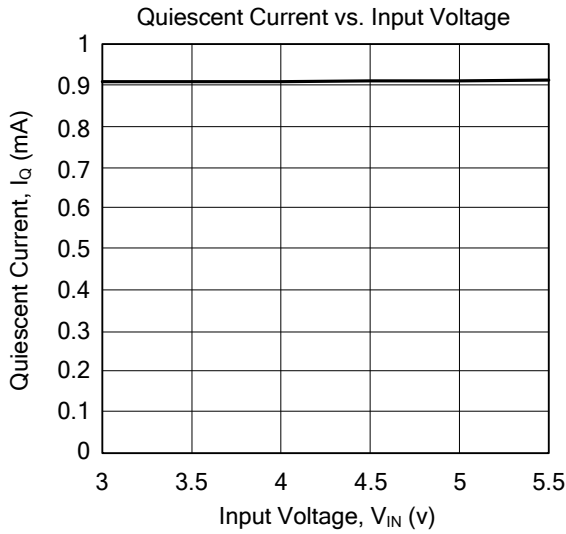

## TYPICAL CHARACTERISTICS(Cont.)

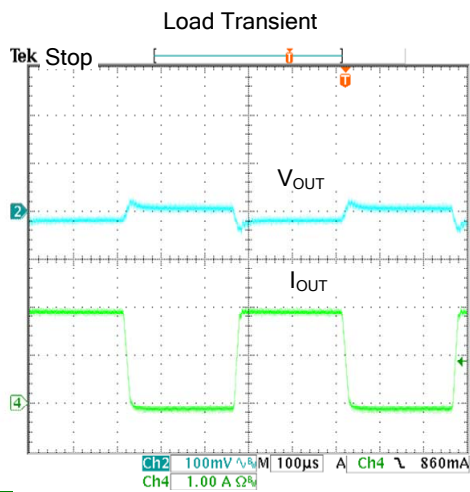
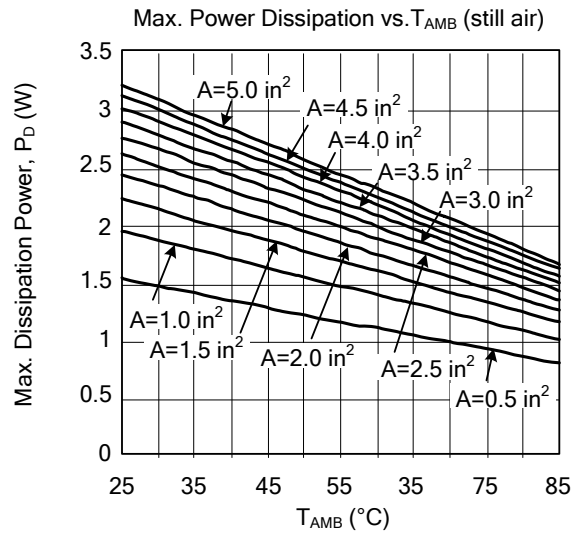
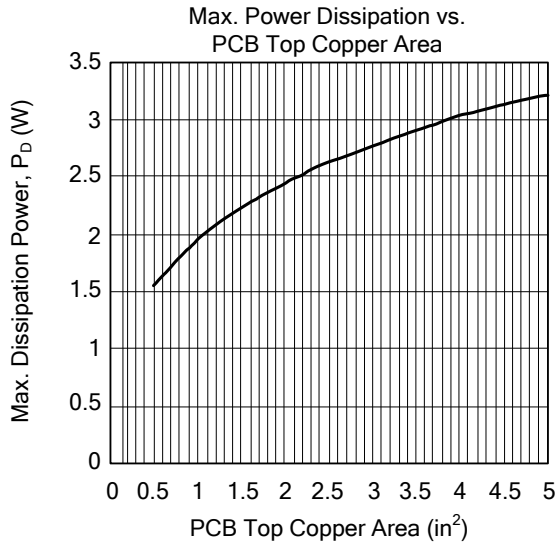
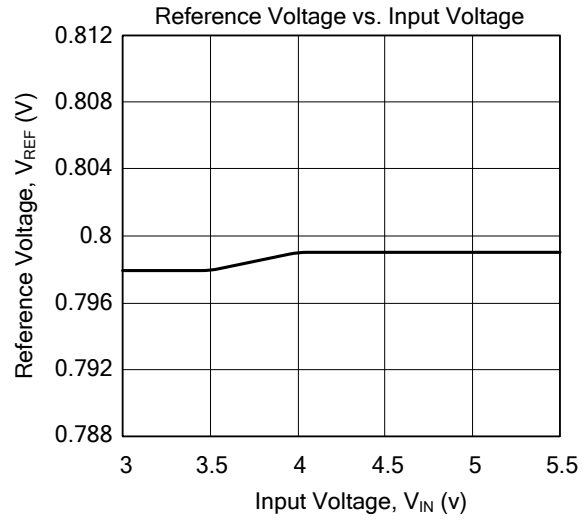
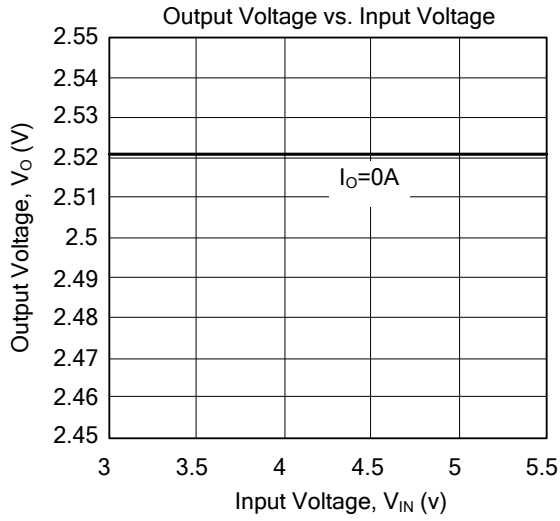

$V_{IN}=3.3V, V_{OUT}=2.5V, I_{OUT}=0$  to 2A

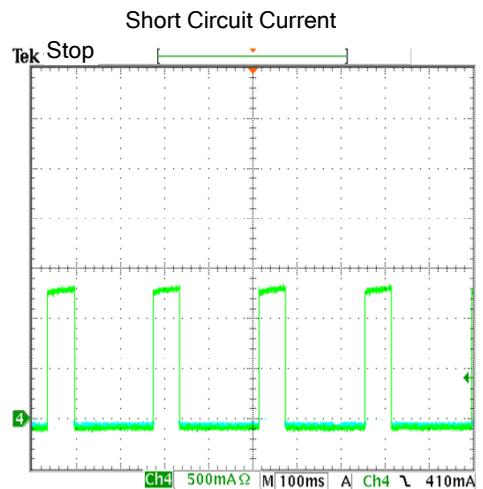

## TYPICAL CHARACTERISTICS(Cont.)

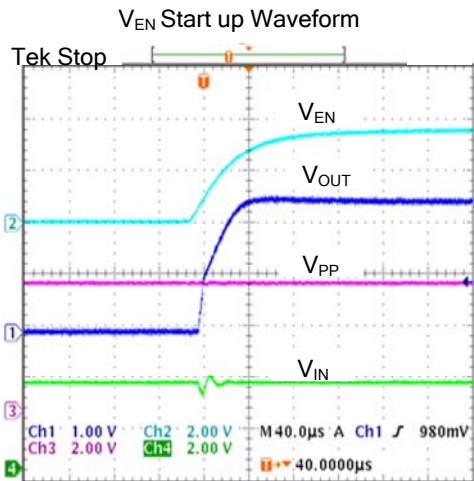
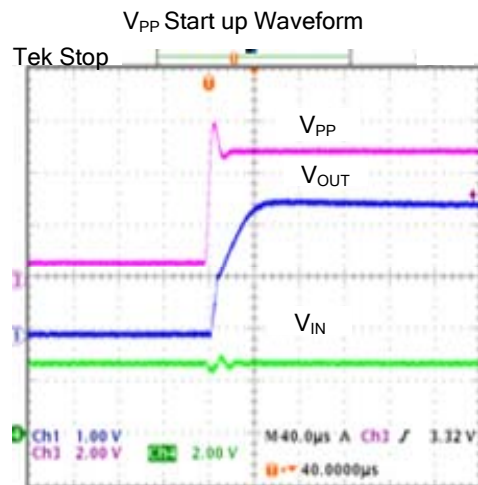
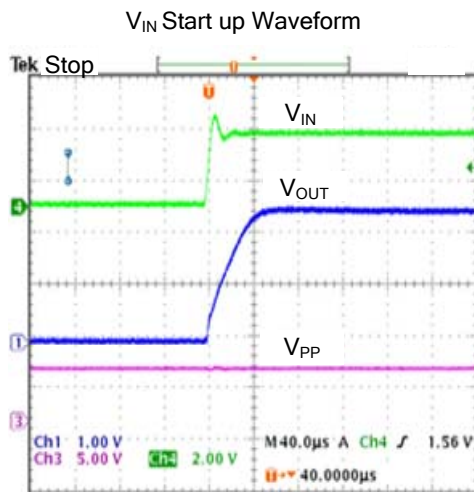

UTC assumes no responsibility for equipment failures that result from using products at values that exceed, even momentarily, rated values (such as maximum ratings, operating condition ranges, or other parameters) listed in products specifications of any and all UTC products described or contained herein. UTC products are not designed for use in life support appliances, devices or systems where malfunction of these products can be reasonably expected to result in personal injury. Reproduction in whole or in part is prohibited without the prior written consent of the copyright owner. The information presented in this document does not form part of any quotation or contract, is believed to be accurate and reliable and may be changed without notice.



## X-ON Electronics

Largest Supplier of Electrical and Electronic Components

*Click to view similar products for [LDO Voltage Regulators](#) category:*

*Click to view products by [Unisonic](#) manufacturer:*

Other Similar products are found below :

[AP7363-SP-13](#) [L79M05TL-E](#) [AP7362-HA-7](#) [PT7M8202B12TA5EX](#) [TCR3DF185,LM\(CT](#) [TCR3DF45,LM\(CT](#) [TLE4473G V52](#) [059985X](#)  
[NCP4687DH15T1G](#) [701326R](#) [NCV8170AXV250T2G](#) [AP7315-25W5-7](#) [AP2111H-1.2TRG1](#) [ZLDO1117QK50TC](#) [AZ1117ID-ADJTRG1](#)  
[TCR3DG12,LF](#) [MIC5514-3.3YMT-T5](#) [SCD7912BTG](#) [NCP154MX180270TAG](#) [SCD33269T-5.0G](#) [NCV8170BXV330T2G](#)  
[NCV8170BMX330TCG](#) [NCV8170AMX120TCG](#) [NCP706ABMX300TAG](#) [NCP153MX330180TCG](#) [NCP114BMX075TCG](#) [MC33269T-3.5G](#)  
[CAT6243-ADJCMT5T](#) [TCR3DG33,LF](#) [TCR4DG35,LF](#) [TAR5S15U\(TE85L,F\)](#) [TAR5S18U\(TE85L,F\)](#) [TCR3UG19A,LF](#) [TCR4DG105,LF](#)  
[MPQ2013AGG-5-P](#) [NCV8170AMX360TCG](#) [TLE4268GSXUMA2](#) [NCP715SQ15T2G](#) [MIC5317-3.0YD5-T5](#) [NCV563SQ18T1G](#)  
[NCP715MX30TBG](#) [NCV8702MX25TCG](#) [NCV8170BXV120T2G](#) [MIC5317-1.2YD5-T5](#) [NCV8170AMX150TCG](#) [NCV8170BMX150TCG](#)  
[AP2213D-3.3TRG1](#) [NCV8170BMX120TCG](#) [NCV8170BMX310TCG](#) [NCV8170BMX360TCG](#)