



M54133A

Preliminary

LINEAR INTEGRATED CIRCUIT

EARTH LEAKAGE CURRENT DETECTOR

■ DESCRIPTION

The UTC **M54133A** is a semiconductor integrated circuit developed for use in high-speed earth leakage breakers incorporating functions to protect against voltage surges and inverter noise.

■ FEATURES

- * Improvement of ability against unwanted tripping by lightning-surge and lightning impulse.
Two times counting system adopted.
- * Improvement of ability against unwanted tripping by inverter-noise.
Built-in operational amplifier (of low current dissipation) for active low-pass filter.
Improved high-frequency, high harmonic superposition performance
- * Internal time delay function
- * An external capacitor is used to set the delay time.
- * High input sensitivity: $V_T=11.5mV_{rms}$ Typ.
- * Low-current dissipation (at $R_{REF}=180k\Omega$)
In stand-by condition: $I_S=610\mu A$ Typ.
- * High stabilities design
Adopt the circuits that is not affected by fluctuations of supply voltage/ambient temperature.

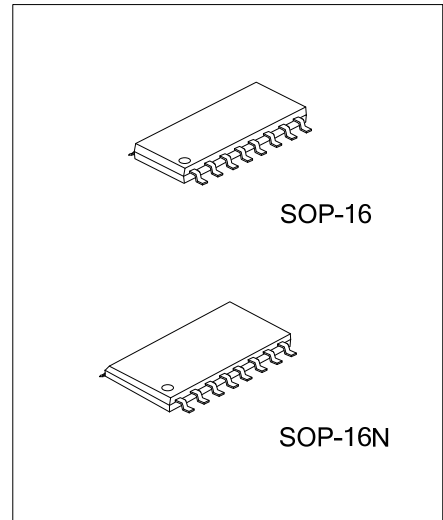

■ ORDERING INFORMATION

Ordering Number		Package	Packing
Lead Free	Halogen Free		
-	M54133AG-S16-R	SOP-16	Tape Reel
M54133AL-S16N-R	M54133AG-S16N-R	SOP-16N	Tape Reel

<p>M54133AL-S16-R</p> <ul style="list-style-type: none"> (1) Packing Type (2) Package Type (3) Green Package 	<ul style="list-style-type: none"> (1) R: Tape Reel (2) S16: SOP-16, S16N: SOP-16N (3) L: Lead Free, G: Halogen Free and Lead Free
-----------------------------------------------------------------------------------------------------------------------------------------------	---------------------------------------------------------------------------------------------------------------------------------------------------------------------

■ MARKING

SOP-16	SOP-16N

■ PIN CONFIGURATION

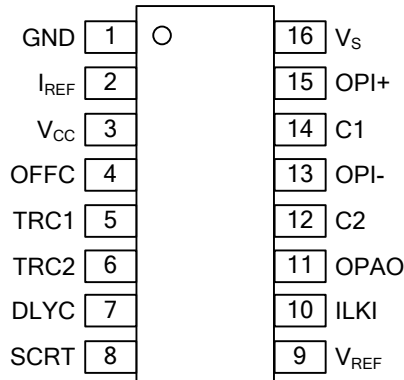

■ PIN DESCRIPTION

PIN NO.	PIN NAME	DESCRIPTION
1	GND	Grounding
2	I _{REF}	Pin for connecting resistor that sets constant current for internal circuits; approx. 1.3 V.
3	V _{CC}	Output pin of the internal constant-voltage circuit. Connect decoupling capacitor.
4	OFFC	Leakage input signal does not continue. Leakage is detected and SCR turn on. In these cases, this IC will be restored to the initial condition after a predetermined time. Connect capacitor that determines restore time.
5	TRC1	Pin for connecting capacitor that integrates signal output from discriminator of leak-signal input level.
6	TRC2	Pin for connecting capacitor to eliminate noise.
7	DLYC	Pin for connecting capacitor that sets delay time in case of using delay function.
8	SCRT	Output pin for driving a SCR.
9	V _{REF}	Pin for providing input reference level of leakage detection. About 2.4V appears.
10	ILKI	Other input pin of leakage detection.
11	OPAO	Output pin of operational amplifier.
12	C2	Pin for connecting capacitor that prevents abnormal oscillations. Connect capacitor across IC at pins 11 and 12.
13	OPI-	Negative input pins of operational amplifier
14	C1	Pin for connecting capacitor that prevents noise from causing malfunction. Connect capacitors across IC at pins 13 and 14 and across IC at pins 15 and 14.
15	OPI+	Positive input pins of operational amplifier
16	VS	Power supply

■ BLOCK DIAGRAM

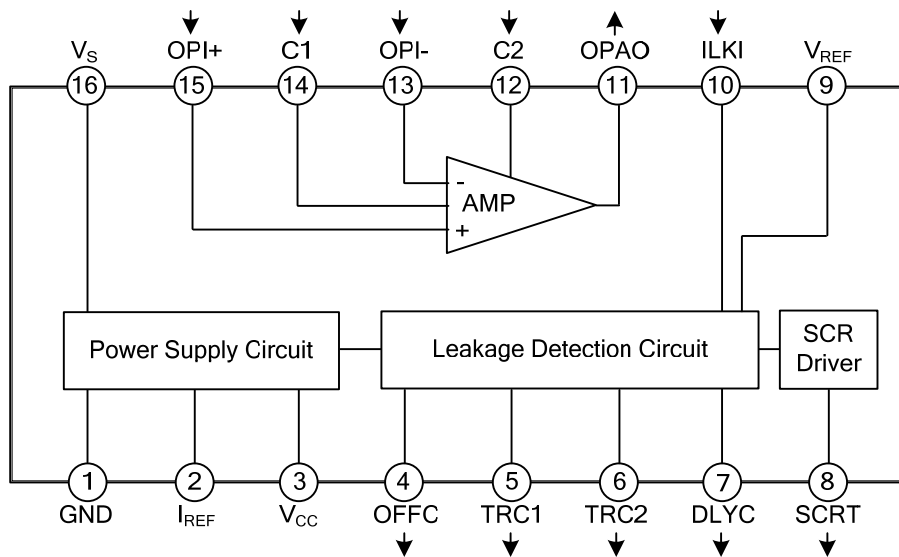

■ ABSOLUTE MAXIMUM RATING ($T_A=25^\circ\text{C}$, unless otherwise noted)

PARAMETER		SYMBOL	RATINGS	UNIT
Maximum Supply Voltage		$V_{S(\text{MAX})}$	15	V
Differential Input Voltage	OPI+ to OPI-	V_{ID}	-0.8~+0.8	V
Supply Current		I_S	4	mA
Differential Input Current	OPI+ to OPI-	I_{IOP}	-5~+5	mA
Input Current	V_{REF} to GND	I_{IG}	10	mA
Power Dissipation		P_D	200	mW
Operating Ambient Temperature		T_{OPR}	-20~+85	$^\circ\text{C}$
Storage Temperature		T_{STG}	-55~+125	$^\circ\text{C}$

Note: Absolute maximum ratings are those values beyond which the device could be permanently damaged. Absolute maximum ratings are stress ratings only and functional device operation is not implied.

■ RECOMMENDED OPERATING CONDITIONS

PARAMETER	SYMBOL	RATINGS	UNIT
Supply Voltage Range	V_S	7 ~ 12	V

■ ELECTRICAL CHARACTERISTICS ($T_A=25^\circ\text{C}$, $V_S=9\text{V}$, unless otherwise noted)

PARAMETER	SYMBOL	TEST CONDITIONS	MIN	TYP	MAX	UNIT
Power Supply Circuit						
Maximum Supply Voltage	$V_{S(\text{MAX})}$	$I_S=4\text{mA}$		13.9	15	V
V_{CC} -Pin Output Voltage	V_{CC}	$I_{\text{OH}}=-1\text{mA}$		5.2		V
Supply Current (In Standby)	I_{S0}		520	610	700	μA
Supply Current (While Detecting Leakage)	I_{S1}		560	650	740	μA
Supply Current (Immediately after Drive a SCR)	I_{S2}		480	570	660	μA
Ambient Temperature Dependence of I_{S0}		$T_A=-25\sim+85^\circ\text{C}$		-0.2		%/ $^\circ\text{C}$
Operational Amplifier						
Differential Input Clamp Voltage	V_{IC}	$I_{\text{DC}}=\pm 4\text{mA}$		± 0.8		V
OPOA-Pin "H" Output Current	I_{OH}			2.8		mA
OPOA-Pin "L" Output Current	I_{OL}			0.8		mA
Input Bias Current	I_{IC}			125		nA
Voltage Gain	G_V	$f=1\text{kHz}$		40		dB
Frequency Band Width	B_W	-3dB		6		kHz
Maximum Output Voltage	V_O			3.5		V_{PP}
Output Offset Voltage	$V_{\text{O(OFF)}}$			0		mV
Leak Detector Circuit						
V_{REF} -Pin Output Voltage	V_O	$I_{\text{OH}}=-200\mu\text{A}$		2.4		V
V_{REF} -GND Clamp Voltage	V_{RCL}	$I_{\text{RCL}}=5\text{mA}$		4.7		V
DC Input Voltage of Leakage Detection	$V_{\text{I(ON)}}$	With respect to V_{REF}		± 14.0		mVdc
ILKI-Pin Input Bias Current	I_{IH}	$V_{\text{IN}}=V_{\text{REF}}$		220		nA
3-ms Circuit						
TRC1 threshold voltage	V_{TH1}			2.4		V
Accuracy of TRC1-Pin "H" Output Current	E_{IOH1}	$V_O=0\text{V}$, $I_{\text{OH1}}=-7.6\mu\text{A}$	-10		+10	%
Accuracy of T_{W1} pulse width	E_{TW1}	$C=0.01\mu\text{f}$, $T_{\text{W1}}=3\text{ms}$	-15		+15	%
Ambient Temperature Dependence of T_{W1}		$T_A=-20\sim+85^\circ\text{C}$		0		%/ $^\circ\text{C}$

■ ELECTRICAL CHARACTERISTICS (Cont.)

PARAMETER	SYMBOL	TEST CONDITIONS	MIN	TYP	MAX	UNIT
1-ms Circuit						
TRC2 Threshold Voltage	V_{TH2}			2.4		V
Accuracy of TRC2-pin "H" Output Current	E_{IOH2}	$V_O=0V, I_{OH2}=-7.6\mu A$	-10		+10	%
Accuracy of TW2 Pulse Width	E_{TW2}	$C=0.0047\mu F, T_{W2}=1.5ms$	-15		+15	%
Ambient Temperature Dependence of V_T		$T_A=+25^\circ C \sim +85^\circ C$		-8.0		%
		$T_A=+25^\circ C \sim -20^\circ C$		+2.0		%
Ambient Temperature Dependence of T_{w2}		$T_A=-20 \sim +85^\circ C$		0		%/ $^\circ C$
Total AC Input Voltage of Leakage Detection	V_T	60Hz		11.5		mVrms
Reset Circuit						
OFFC Threshold Voltage	V_{TH}			2.4		V
Accuracy of OFFC-pin "H" Output Current	E_{IOH}	$V_O=0V, I_{OH}=-7.6\mu A$	-10		+10	%
Accuracy of Reset Time Pulse Width	E_{TW3}	$C=0.33\mu F, T_{W3}=75ms$	-30		+30	%
Delay Circuit						
DLYC Threshold Voltage	V_{TH}			2.4		V
Accuracy of DLYC-pin "H" Output Current	E_{IOH}	$V_O=0V, I_{OH}=-7.6\mu A$	-10		+10	%
Accuracy of Delay Timer Pulse Width	E_{TW4}	$C=1.0\mu F, T_{W4}=300ms$	-30		+30	%
SCR Driver Circuit						
SCRT-Pin "L" Output Voltage	V_{OL8}	$I_{OL}=200\mu A$		0.1	0.2	V
Supply Voltage for I_{OH} Hold	$V_{S(OFF)}$			3.0	4.0	V
SCRT-Pin "H" Output Current	I_{OHC}	$V_O=8V$	$T_A=-20^\circ C$	-100	-160	μA
	I_{OHN}		$T_A=+20^\circ C$	-50	-130	μA
	I_{OHH}		$T_A=+85^\circ C$	-33	-100	μA

■ WITHOUT DELAY FUNCTION

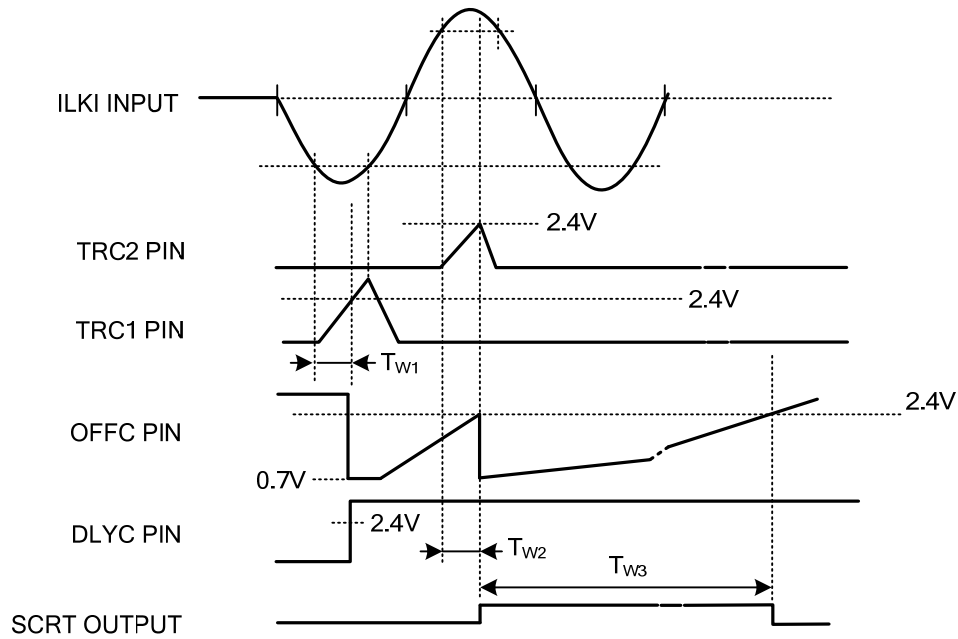

Without Delay Function

■ USING DELAY FUNCTION

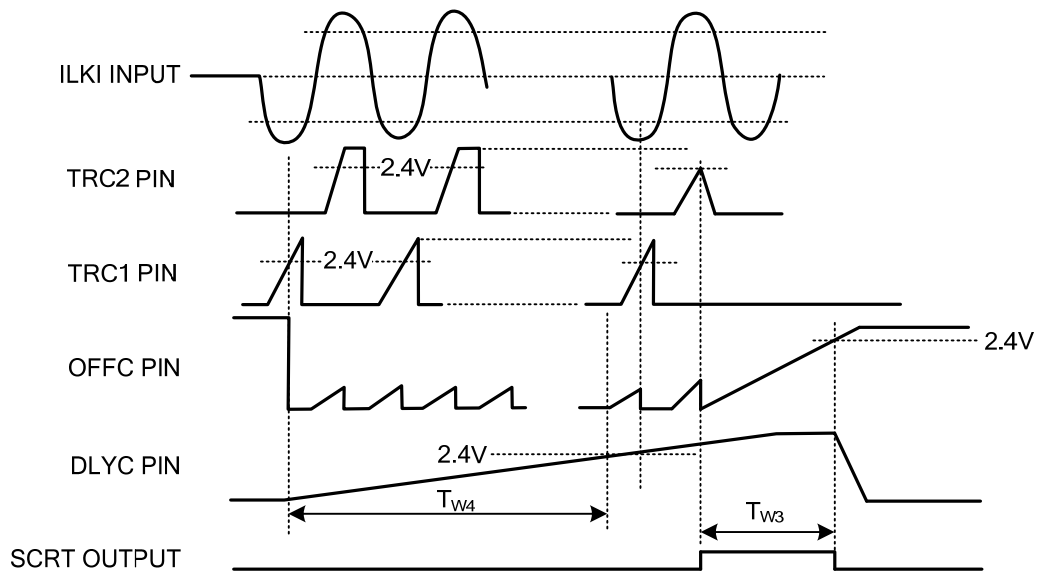

Using Delay Function

■ TYPICAL APPLICATION CIRCUIT

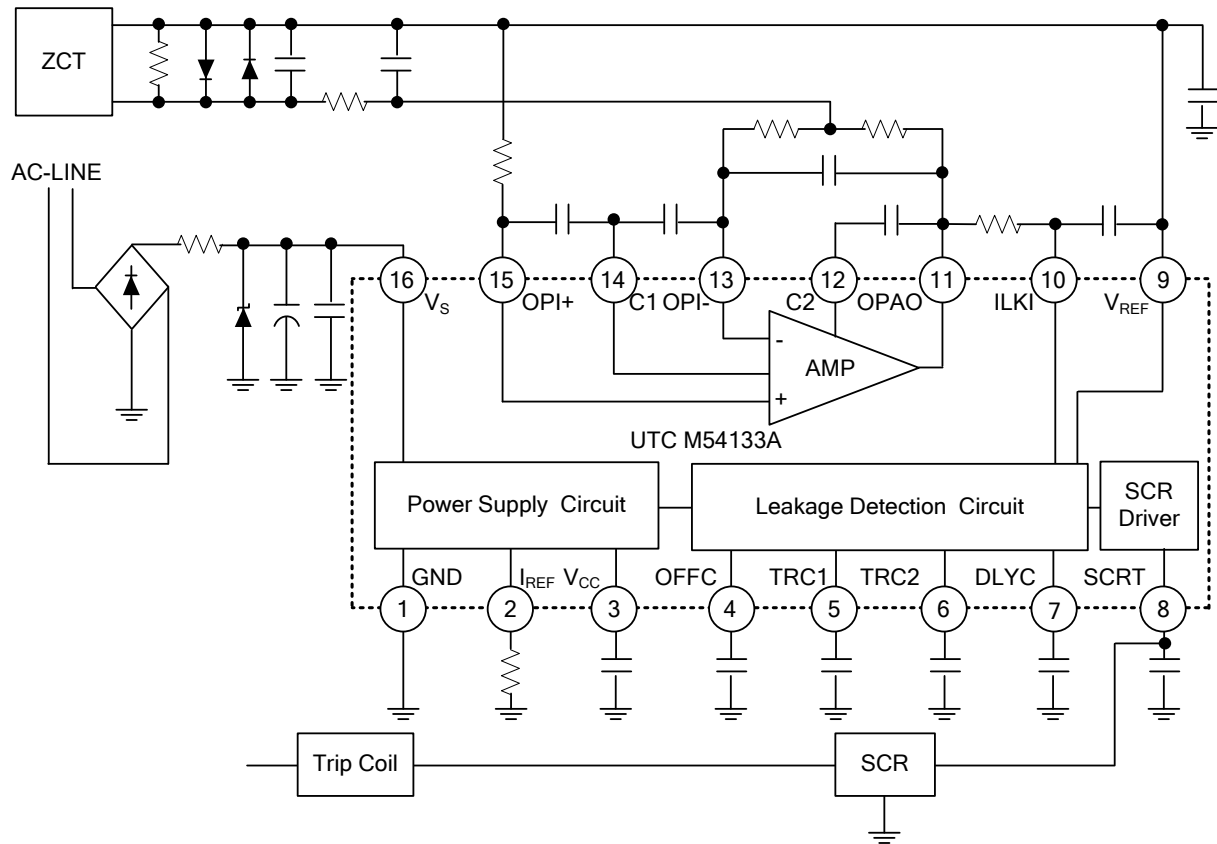

UTC assumes no responsibility for equipment failures that result from using products at values that exceed, even momentarily, rated values (such as maximum ratings, operating condition ranges, or other parameters) listed in products specifications of any and all UTC products described or contained herein. UTC products are not designed for use in life support appliances, devices or systems where malfunction of these products can be reasonably expected to result in personal injury. Reproduction in whole or in part is prohibited without the prior written consent of the copyright owner. The information presented in this document does not form part of any quotation or contract, is believed to be accurate and reliable and may be changed without notice.

X-ON Electronics

Largest Supplier of Electrical and Electronic Components

Click to view similar products for [Power Management Specialised - PMIC category](#):

Click to view products by [Unisonic manufacturer](#):

Other Similar products are found below :

[LV5686PVC-XH](#) [FAN7710VN](#) [NCP391FCALT2G](#) [SLG7NT4081VTR](#) [SLG7NT4192VTR](#) [AP4313UKTR-G1](#) [MB39C831QN-G-EFE2](#)

[LV56841PVD-XH](#) [S6AE102A0DGN1B200](#) [MMPF0100FDAEP](#) [S6AE101A0DGNAB200](#) [NCP6924CFCHT1G](#) [AP4306BUKTR-G1](#)

[IR35217MTRPBF](#) [MIC5164YMM](#) [PT8A3252WE](#) [NCP6914AFCAT1G](#) [NCP392CSFCCT1G](#) [TEA1998TS/1H](#) [PT8A3284WE](#)

[LTC3643EUDD#PBF](#) [TEA2095T/1/S30J](#) [PCA9420BSAZ](#) [MC33PF8100FJES](#) [ISL91211AIKZT7AR5874](#) [ISL91211BIKZT7AR5878](#)

[ISL91212AIIZ-TR5770](#) [ISL91212BIIZ-TR5775](#) [MC34VR5100A1EP](#) [AX-3003D-3](#) [AX-3005D-3](#) [TP-1305](#) [TP-2305](#) [TP-30102](#) [TP-4503N](#)

[MIC5167YML-TR](#) [MPS-3003L-3](#) [MPS-3005D](#) [NCP392ARFCCT1G](#) [SPD-3606](#) [STLUX383A](#) [TP-60052](#) [ADN8834ACBZ-R7](#)

[LM81BIMTX-3/NOPB](#) [LM81CIMT-3/NOPB](#) [LP2996AMRX/NOPB](#) [LP2996AMRENOPB](#) [LV5696P-E](#) [ADT7462ACPZ-REEL](#) [GPE-4323](#)