



MC3361BP

LINEAR INTEGRATED CIRCUIT

LOW VOLTAGE/POWER NARROW BAND FM IF

DESCRIPTION

The UTC MC3361BP is designed for use in FM dual conversion communication. It contains a complete narrow band FM demodulation system operable to less than 2.5V supply voltage. This low-power narrow-band FM IF system provides the second converter, second IF, demodulator. Filter Amp and squelch circuitry for communications and scanning receivers.

FEATURES

- *Low power consumption (4.0mA typ. at Vcc=4.0V)
- *Excellent input sensitivity (-3dB limiting, 2.0µVrms typ.)
- *Minimum number of external components required.
- *Operating Voltage: 2.5~7.0V

APPLICATIONS

- *Cordless phone (for home use)
- *FM dual conversion communications equipment

ORDERING INFORMATION

Order Number		Package	Packing
Lead Free	Halogen Free		
MC3361BPL-D16-T	MC3361BPG-D16-T	DIP-16	Tube
-	MC3361BPG-N16-R	TSSOP-16	Tape Reel
-	MC3361BPG-S16-R	SOP-16	Tape Reel

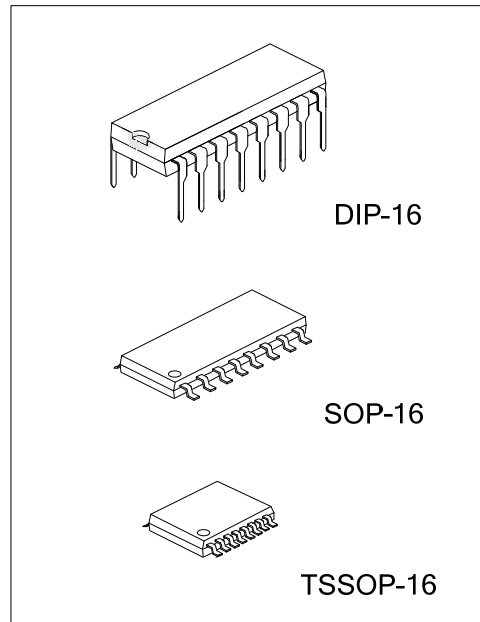

<p>MC3361BPL-D16-T</p> <p>(1)Packing Type</p> <p>(2)Package Type</p> <p>(3)Green Package</p>	<p>(1) T: Tube, R: Tape Reel</p> <p>(2) D16: DIP-16, N16: TSSOP-16, S16: SOP-16</p> <p>(3) L: Lead Free, G: Halogen Free and Lead Free</p>
--	--

MARKING

DIP-16	SOP-16 / TSSOP-16

■ PIN CONFIGURATION

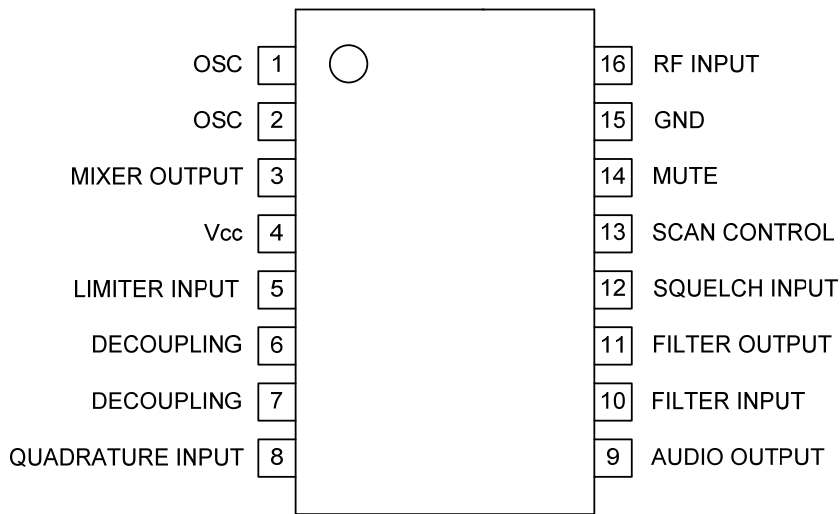

■ BLOCK DIAGRAM

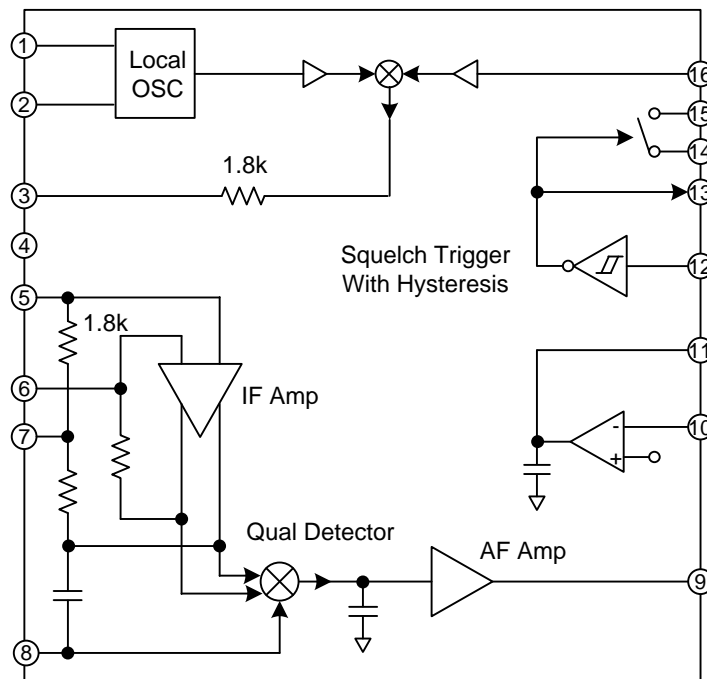

■ ABSOLUTE MAXIMUM RATINGS (T_A=25°C)

PARAMETER	SYMBOL	RATING	UNIT
Max. Supply Voltage	V _{CC(MAX)}	10	V
Supply Voltage Range	V _{CC}	2.5 to 7.0	V
Detector Input voltage	V _{I(DET)}	1.0	Vp-p
RF Input Voltage (V _{CC} ≥ 4.0V)	V _{I(RF)}	1.0	V _{rms}
Mute Function	V _{MUTE}	-0.5 ~ + 5.0	V _{peak}
Operating Temperature	T _{OPR}	-20 ~ +70	°C
Storage Temperature	T _{STG}	-65 ~ +150	°C

Note: Absolute maximum ratings are those values beyond which the device could be permanently damaged.

Absolute maximum ratings are stress ratings only and functional device operation is not implied.

■ ELECTRICAL CHARACTERISTICS

(V_{CC}=4.0V, f_o=10.7MHz, Δf=±3KHz, f_{MOD}=1KHz, T_a=25°C, unless otherwise specified)

PARAMETER	SYMBOL	TEST CONDITIONS	MIN	TYP	MAX	UNIT
Operating Current	I _{CC}	Squelch OFF (V ₁₂ =2V)		4.0		mA
		Squelch ON (V ₁₂ =GND)		6.0		mA
Input Limiting Voltage	V _{I(LIMIT)}	-3.0dB limiting		2.0		μV
Detector Output Voltage	V _{O(DET)}			2.0		V _{dc}
Detector Output Impedance	Z _{O(DET)}			400		Ω
Audio Output Voltage	V _O	V _{IN} =10mV	100	160		mV _{rms}
Filter Gain	G _V	f=10KHz, V _{IN} =5mV	40	48		dB
Filter Output DC Voltage	V _{O(DC)}			1.5		V _{dc}
Trigger Hysteresis of Filter	V _{TH}			50		mV
Mute Switch-ON Resistance	R _{ON(MUTE)}	Mute "Low"		10		Ω
Mute Switch-OFF Resistance	R _{OFF(MUTE)}	Mute "High"		10		MΩ
Scan Control "Low" Output	V _{L(SCAN)}	Mute OFF (V ₁₂ =2V)			0.5	V _{dc}
Scan Control "High" Output	V _{H(SCAN)}	Mute ON (V ₁₂ =GND)	3.0			V _{dc}
Mixer Conversion Gain	G _{V(MIXER)}			24		dB
Mixer Input Resistance	R _{I(MIXER)}			3.3		KΩ
Mixer Input Capacitance	C _{I(MIXER)}			2.2		pF

APPLICATION CIRCUIT

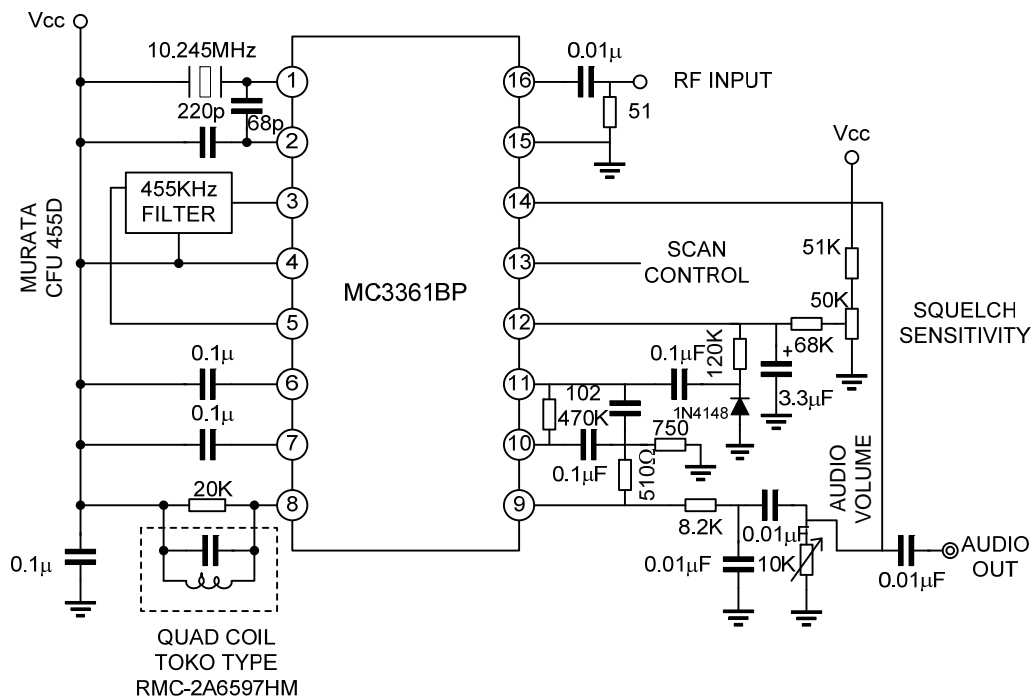

In the above typical application, the audio signal is recovered using a conventional quadrature FM detector. The absence of an input signal is indicated by the presence of noise above the desired audio frequencies. This "noise band" is monitored by an active filter and a detector. A squelch trigger circuit indicates the presence of noise (or a tone) by an output which can be used to control scanning. At the same time, an internal switch is operated which can be used to mute the audio.

UTC assumes no responsibility for equipment failures that result from using products at values that exceed, even momentarily, rated values (such as maximum ratings, operating condition ranges, or other parameters) listed in products specifications of any and all UTC products described or contained herein. UTC products are not designed for use in life support appliances, devices or systems where malfunction of these products can be reasonably expected to result in personal injury. Reproduction in whole or in part is prohibited without the prior written consent of the copyright owner. The information presented in this document does not form part of any quotation or contract, is believed to be accurate and reliable and may be changed without notice.

X-ON Electronics

Largest Supplier of Electrical and Electronic Components

Click to view similar products for [RF Transceiver category](#):

Click to view products by [Unisonic manufacturer](#):

Other Similar products are found below :

[MRF89XAM9AT-I/RM](#) [AX5051-1-TW30](#) [BGT24LTR22E6327XTSA1](#) [SI4461-C2A-GMR](#) [CC1260RGZT](#) [NRF51822-CEAA-R \(E0\)](#)
[725TRX8-1K](#) [725TRX8-16K](#) [AMB2561](#) [SI4455-C2A-GMR](#) [MICRF505YML-TR](#) [S2-LPQTR](#) [AT86RF232-ZX](#) [SI4463-B1B-ZM0R](#)
[ATA8510-GHQW](#) [CC8530RHAR](#) [CC1201RHBR](#) [TC35675XBG-001\(EL\)](#) [SX1281IMLTRT](#) [Si4055-C2A-GM](#) [A7108](#) [ADF7020-1BCPZ-](#)
[RL7](#) [ADF7021BCPZ-RL](#) [ADF7021BCPZ-RL7](#) [ADF7021-NBCPZ](#) [AT86RF231-ZU](#) [AT86RF232-ZXR](#) [AT86RF233-ZF](#) [AT86RF233-ZU](#)
[ATA8520-GHQW](#) [AT86RF233-ZFR](#) [BRAVO-T868](#) [CYWUSB6934-48LTXC](#) [CMT2119A-ESR](#) [CMT2110A-ESR](#) [F113](#) [PT4455](#)
[SX1236IMLTRT](#) [ECC961616EU](#) [LR690-N](#) [HT9170D](#) [CMT2210LC-ESR2](#) [BGT 24MTR11 E6327](#) [BGT24MTR11E6327XUMA1](#)
[BGT24MTR12E6327XUMA1](#) [LMS7002M](#) [SX1212IWLTRT](#) [SX1211I084TRT](#) [MAX9947ETE+T](#) [AT86RF231-ZUR](#)