



P1690

LINEAR INTEGRATED CIRCUIT

0.4A, 150KHZ 65V BUCK DC TO DC CONVERTER

DESCRIPTION

The UTC **P1690** is a PWM buck (step-down) DC/DC converter, fixed frequency of 150KHz, capable of driving a 0.4A load with high efficiency, low ripple and excellent line and load regulation.

The P1690 built kinds of protect circuit inside. Such as OTP SCP and so on.

FEATURES

- * Wide 5V~ 65V Operation Voltage
- * Output Adjustable from 1.25V~25V
- * High efficiency up to 85%
- * Maximum Duty Cycle 100%
- * Fixed 150KHz Switching Frequency
- * Built in OTP
- * Built in SCP
- * Built in OCP

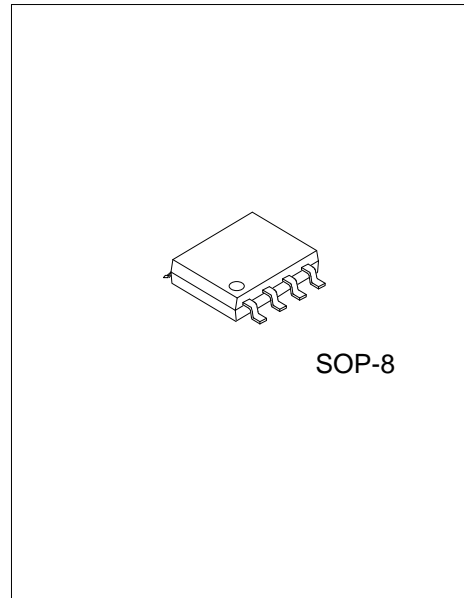

ORDERING INFORMATION

Ordering Number		Package	Packing
Lead Free	Halogen Free		
P1690L-S08-R	P1690G-S08-R	SOP-8	Tape Reel

<p>P1690G-S08-R</p> <ul style="list-style-type: none"> (1) Packing Type (2) Package Type (3) Green Package 	<ul style="list-style-type: none"> (1) R: Tape Reel (2) S08: SOP-8 (3) G: Halogen Free and Lead Free, L: Lead Free
---	---

MARKING

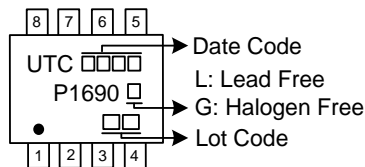

■ PIN CONFIGURATION

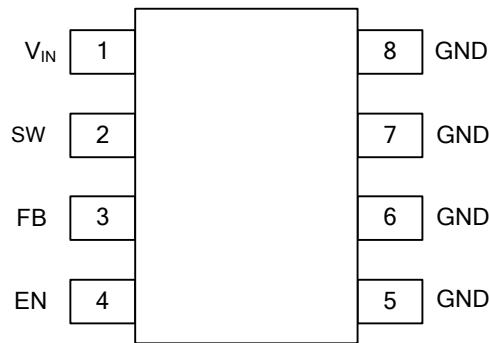

■ PIN DESCRIPTION

PIN NO.	PIN NAME	DESCRIPTION
1	V _{IN}	Supply Voltage Input Pin.
2	SW	Power Switch Output Pin (SW).
3	FB	Feedback voltage Pin (FB).
4	EN	Enable Pin.
5,6,7,8	GND	Ground Pin.

■ BLOCK DIAGRAM

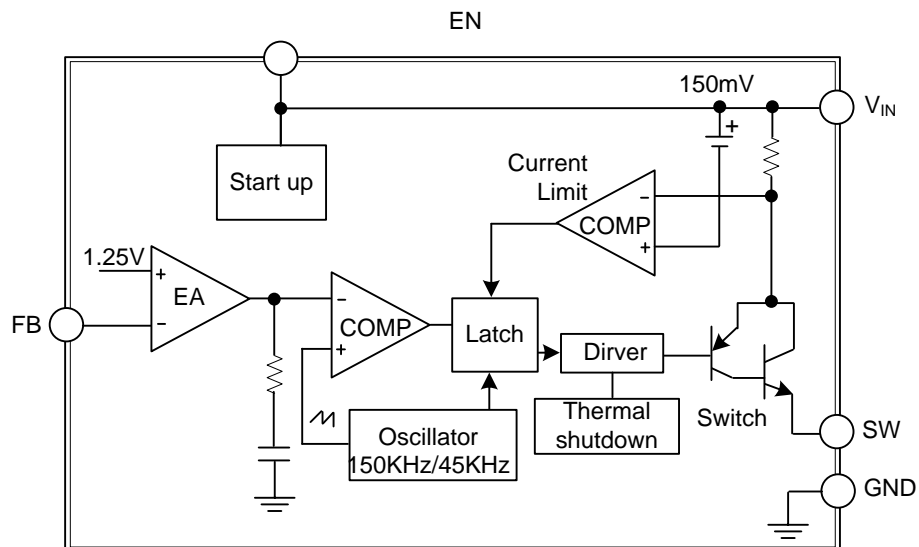

■ ABSOLUTE MAXIMUM RATING

PARAMETER	SYMBOL	RATINGS	UNIT
Input Voltage	V_{IN}	-0.3 ~ 70	V
Feedback Pin Voltage	V_{FB}	-0.3 ~ V_{IN}	V
EN Pin Voltage	V_{EN}	-0.3 ~ V_{IN}	V
Output Switch Pin Voltage	V_{SW}	-0.3 ~ V_{IN}	V
Power Dissipation	P_D	Internally limited	mW
Junction to Ambient, No Heatsink, Free Air	θ_{JA}	60	°C/W
Operating Junction Temperature	T_J	-40 ~ 125	°C
Storage Temperature	T_{STG}	-65 ~ 150	°C

Note: Absolute maximum ratings are those values beyond which the device could be permanently damaged. Absolute maximum ratings are stress ratings only and functional device operation is not implied.

■ ELECTRICAL CHARACTERISTICS ($T_A=25^\circ\text{C}$ unless otherwise specified)

PARAMETER	SYMBOL	TEST CONDITIONS	MIN	TYP	MAX	UNIT
System Parameters Test Circuit Figure1						
FB Voltage	V_{FB}	$V_{IN}=36\text{V}\sim 65\text{V}$, $I_{load}=0.05\text{A}\sim 0.3\text{A}$	1.225	1.25	1.275	V
Efficiency	η	$V_{IN}=36\text{V}$, $V_{OUT}=15\text{V}$, $I_{OUT}=0.3\text{A}$		88		%
Efficiency	η	$V_{IN}=48\text{V}$, $V_{OUT}=15\text{V}$, $I_{OUT}=0.4\text{A}$		87		%
Efficiency	η	$V_{IN}=60\text{V}$, $V_{OUT}=15\text{V}$, $I_{OUT}=0.4\text{A}$		83		%

■ ELECTRICAL CHARACTERISTICS (DC PARAMETERS)

($V_{IN}=48\text{V}$, $GND=0\text{V}$, V_{IN} & GND parallel connect a 33uf/100V capacitor; $I_{OUT}=0.2\text{A}$, $T_A=25^\circ\text{C}$ the others floating unless otherwise specified)

PARAMETER	SYMBOL	TEST CONDITIONS	MIN	TYP	MAX	UNIT
Input Operation Voltage	V_{IN}		5		65	V
Shutdown Supply Current	I_{STBY}	$V_{EN}=2\text{V}$		85	200	μA
Quiescent Supply Current	I_q	$V_{ON/OFF}=0\text{V}$, $V_{FB}=V_{IN}$		2.5	5	mA
Oscillator Frequency	F_{OSC}		120	150	180	KHz
Switch Current Limit	I_L	$V_{FB}=0$		0.4		A
EN Pin Threshold	V_{EN}	High (Regulator OFF)		1.6		V
		Low (Regulator ON)		0.8		V
EN Pin Input Leakage Current	I_H	$V_{EN}=2.5\text{V}$ (OFF)		6	20	μA
	I_L	$V_{EN}=0.5\text{V}$ (ON)		1	20	μA
Output Saturation Voltage	V_{CE}	$V_{FB}=0\text{V}$, $I_{OUT}=0.4\text{A}$		0.85		V
Max. Duty Cycle	D_{MAX}	$V_{FB}=0\text{V}$		100		%

■ TYPICAL APPLICATION CIRCUIT

$V_{OUT}=15V$

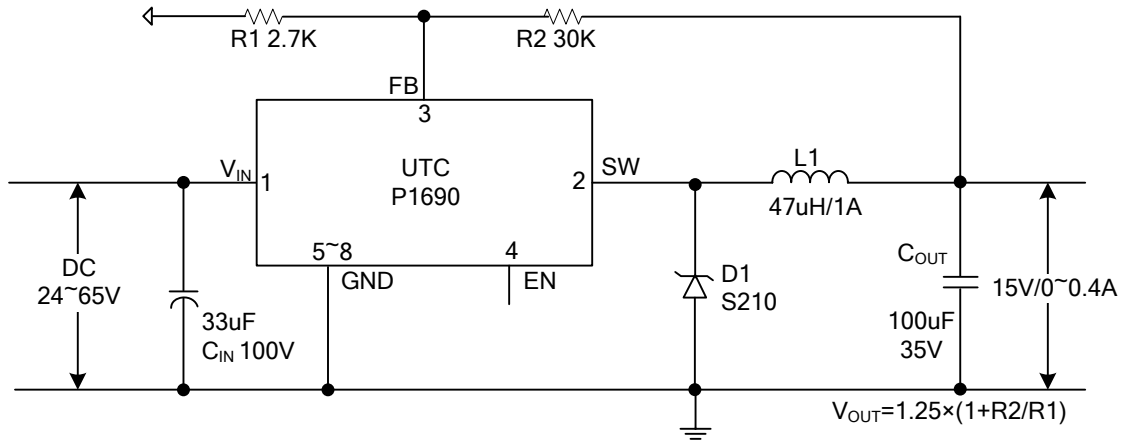

Figure 1.

$V_{OUT}=5V$

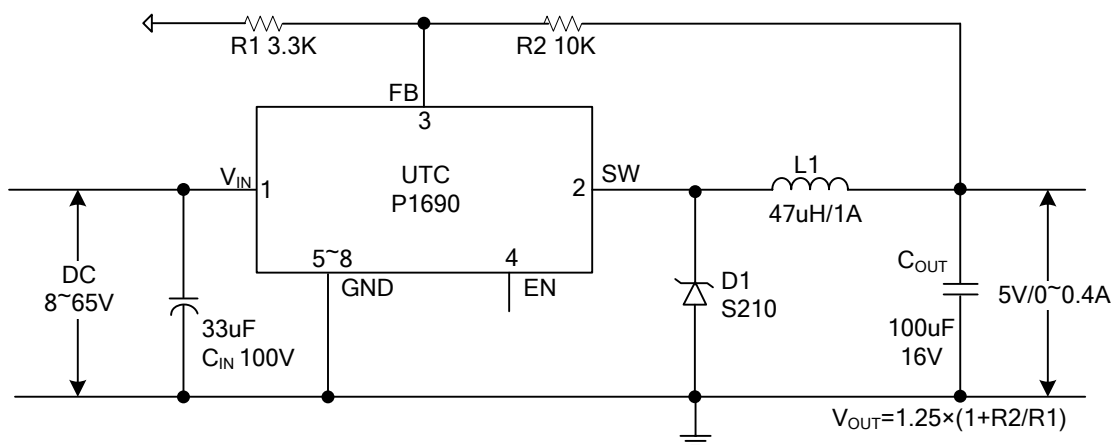
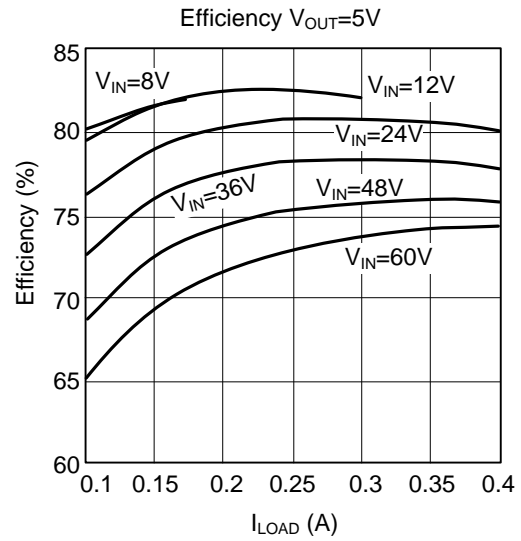
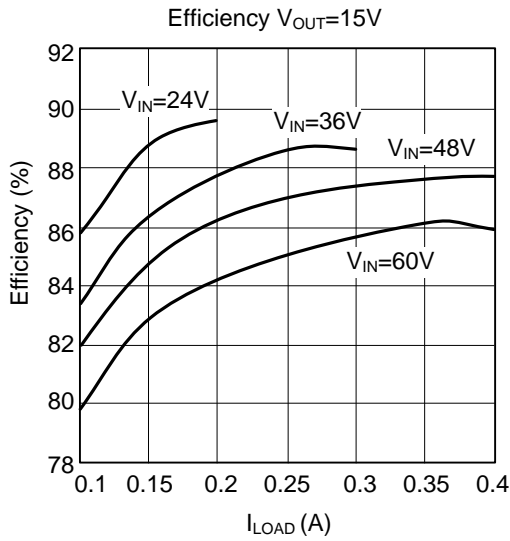

Figure 2

Note: Under different input and output voltage, in order to achieve loop stability, the need to use different capacity inductance.

■ TYPICAL CHARACTERISTICS



UTC assumes no responsibility for equipment failures that result from using products at values that exceed, even momentarily, rated values (such as maximum ratings, operating condition ranges, or other parameters) listed in products specifications of any and all UTC products described or contained herein. UTC products are not designed for use in life support appliances, devices or systems where malfunction of these products can be reasonably expected to result in personal injury. Reproduction in whole or in part is prohibited without the prior written consent of the copyright owner. The information presented in this document does not form part of any quotation or contract, is believed to be accurate and reliable and may be changed without notice.

X-ON Electronics

Largest Supplier of Electrical and Electronic Components

Click to view similar products for [Switching Controllers](#) category:

Click to view products by [Unisonic](#) manufacturer:

Other Similar products are found below :

[NCP1218AD65R2G](#) [NCP1244BD065R2G](#) [NCP6153MNTWG](#) [NCP81101BMNTXG](#) [NCP81205MNTXG](#) [SJE6600](#) [SG3845DM](#)
[NCP4204MNTXG](#) [NCP6132AMNR2G](#) [NCP81102MNTXG](#) [NCP81206MNTXG](#) [MAX1653ESET](#) [NCP1240FD065R2G](#)
[NCP1361BABAYSNT1G](#) [NCP1230P100G](#) [NX2124CSTR](#) [NCP1366BABAYDR2G](#) [NCP81174NMNTXG](#) [NCP4308DMTTWG](#)
[NCP4308AMTTWG](#) [NCP1366AABAYDR2G](#) [NCP1251FSN65T1G](#) [NCP1246BLD065R2G](#) [NTE7233](#) [ISL69122IRAZ](#) [MB39A136PFT-G-](#)
[BND-ERE1](#) [NCP1256BSN100T1G](#) [LV5768V-A-TLM-E](#) [NCP1365BABCYDR2G](#) [NCP1365AABCYDR2G](#) [NCP1246ALD065R2G](#)
[AZ494AP-E1](#) [CR1510-10](#) [NCP4205MNTXG](#) [XC9221C093MR-G](#) [XRP6141ELTR-F](#) [RY8017](#) [LP6260SQVF](#) [LP6298QVF](#) [ISL6121LIB](#)
[ISL6225CA](#) [ISL6244HRZ](#) [ISL6268CAZ](#) [ISL6315IRZ](#) [ISL6420AIAZ-TK](#) [ISL6420AIRZ](#) [ISL6420IAZ](#) [ISL6421ERZ](#) [ISL6440IA](#)
[ISL6441IRZ-TK](#)