



TDA7052A

LINEAR INTEGRATED CIRCUIT

1W BTL MONO AUDIO AMPLIFIER WITH DC VOLUME CONTROL

DESCRIPTION

The UTC **TDA7052A** is mono BTL output amplifier with DC volume control. It is designed for use in TV and monitors, additionally it is suitable for portable recorders and radios.

In the IC, a Missing Current Limiter (MCL) is built-in. This function is activated when the difference of current between the OUT+ and OUT- exceed 100mA (typical 300mA). This level of 100mA suit for headphone applications (single-ended).

FEATURES

- * Low power consumption
- * DC volume control
- * Mute mode
- * No switch-on and off clicks
- * Short-circuit proof
- * Good overall stability
- * Low HF radiation
- * Few external components
- * Thermal protection
- * ESD protected on all pins
- * Missing Current Limiter (MCL)

ORDERING INFORMATION

Ordering Number		Package	Packing
Lead Free	Halogen Free		
TDA7052AL-D08-T	TDA7052AG-D08-T	DIP-8	Tube
TDA7052AL-S08-T	TDA7052AG-S08-T	SOP-8	Tube
TDA7052AL-S08-R	TDA7052AG-S08-R	SOP-8	Tape Reel

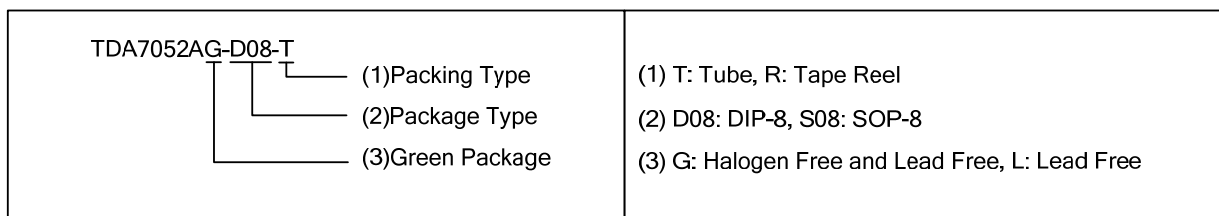

MARKING

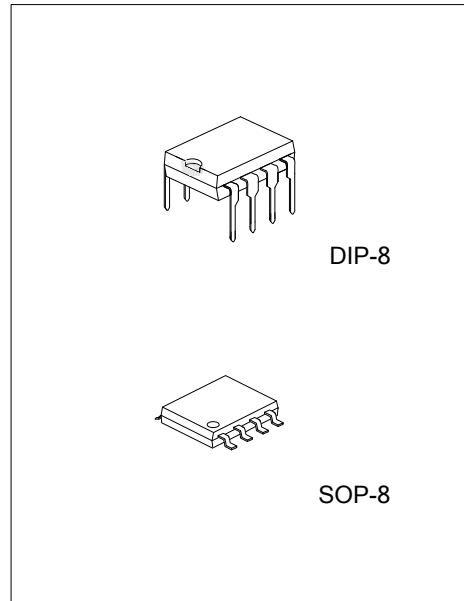
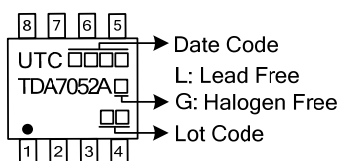

PIN CONFIGURATION

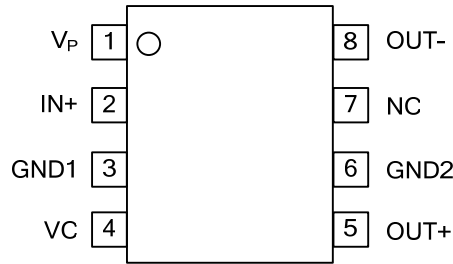

PIN DESCRIPTION

PIN NO.	PIN NAME	DESCRIPTION
1	V _P	Power Supply
2	IN+	Signal Input Terminal
3	GND1	Signal Ground
4	VC	DC Volume Control Terminal
5	OUT+	Non-inverted Output Terminal
6	GND2	Power Ground
7	NC	Not Connected
8	OUT-	Inverted Output Terminal

BLOCK DIAGRAM

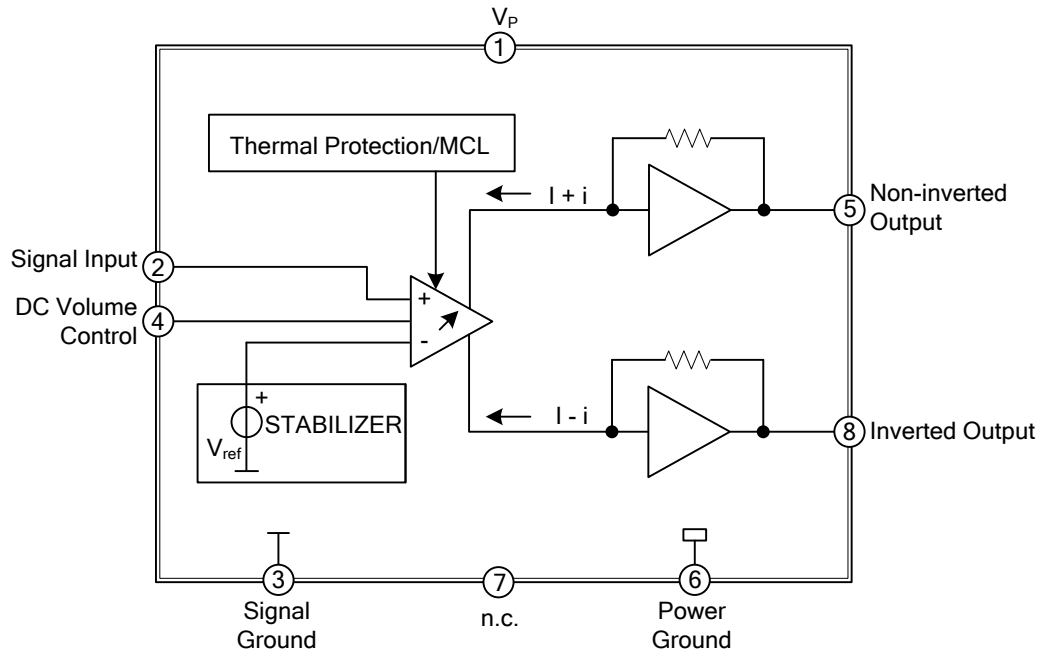

■ ABSOLUTE MAXIMUM RATING

PARAMETER	SYMBOL	RATINGS	UNIT
Supply Voltage Range	V_P	18	V
Input Voltage Pin 2	V_2	8	V
Input Voltage Pin 4	V_4	8	V
Repetitive Peak Output Current	I_{ORM}	1.25	A
Non-Repetitive Peak Output Current	I_{OSM}	1.5	A
Short-Circuit Time	T_{SC}	1	hr
Total Power Dissipation ($T_A \leq 25\%$)	DIP-8	1.25	W
	SOP-8	0.8	W
Operating Ambient Temperature Range	T_A	-40 ~ +85	°C
Junction Temperature	T_J	+150	°C
Storage Temperature Range	T_{STG}	-55 ~ +150	°C

Note: Absolute maximum ratings are those values beyond which the device could be permanently damaged. Absolute maximum ratings are stress ratings only and functional device operation is not implied.

■ ELECTRICAL CHARACTERISTICS

$V_P=6V$, $T_{amb}=25^\circ C$, $f=1kHz$; $R_L=8\Omega$, unless otherwise specified.

PARAMETER	SYMBOL	TEST CONDITIONS	MIN	TYP	MAX	UNIT
Power Supply Voltage Range	V_P		4.5		18	V
Total Quiescent Current	I_P	$V_P=6V$, $R_L=\infty$, Note 1		7	12	mA
DC Volume Control						
Gain Control Range	ϕ		75	80		dB
Control Current	I_4	$V_4=0.4V$		70	80	μA
Characteristics In Mute Position						
Output Voltage In Mute Position	V_O	$V_4 \leq 0.3V$, $V_I=600mV$			30	μV
Characteristics In Minimum Gain, $V_4=0.5V$						
Voltage Gain	G_V			-44		dB
Noise Output Voltage (RMS value)	$V_{NO(RMS)}$	Note 2		20	30	μV
Characteristics In Maximum Gain, $V_4=1.4V$						
Output Power	P_O	THD=10%	1.0	1.1		W
Total Harmonic Distortion	THD	$P_O=0.5W$		0.3	1	%
Voltage Gain	G_V		34.5	35.5	36.5	dB
Input Signal Handling	V_I	$V_4=0.8V$, THD<1%	0.5	0.65		V
Noise Output Voltage (RMS value)	$V_{NO(RMS)}$	$f=500kHz$, Note 3		210		μV
Bandwidth	B	-1dB		0.02~300		kHz
Supply Voltage Ripple Rejection	SVRR	Note 4	38	46		dB
DC Output Offset Voltage	$ V_{OFF} $			0	150	mV
Input Impedance (Pin 2)	Z_I		15	20	25	k Ω

Notes: 1. With a load connected to the outputs the quiescent current will increase, the maximum value of this increase being equal to the DC output offset voltage dividend by R_L .

2. The noise output voltage (RMS value) is measured with $R_S=5k\Omega$ unweighted.

3. The noise output voltage (RMS value) at $f=500kHz$ is measured with $R_S=0\Omega$ and bandwidth=5kHz.

4. The ripple rejection is measured with $R_S=0\Omega$ and $f=100Hz \sim 10kHz$. The ripple voltage of 200mV, (RMS value) is applied to the positive supply rail.

■ TYPICAL APPLICATION CIRCUIT

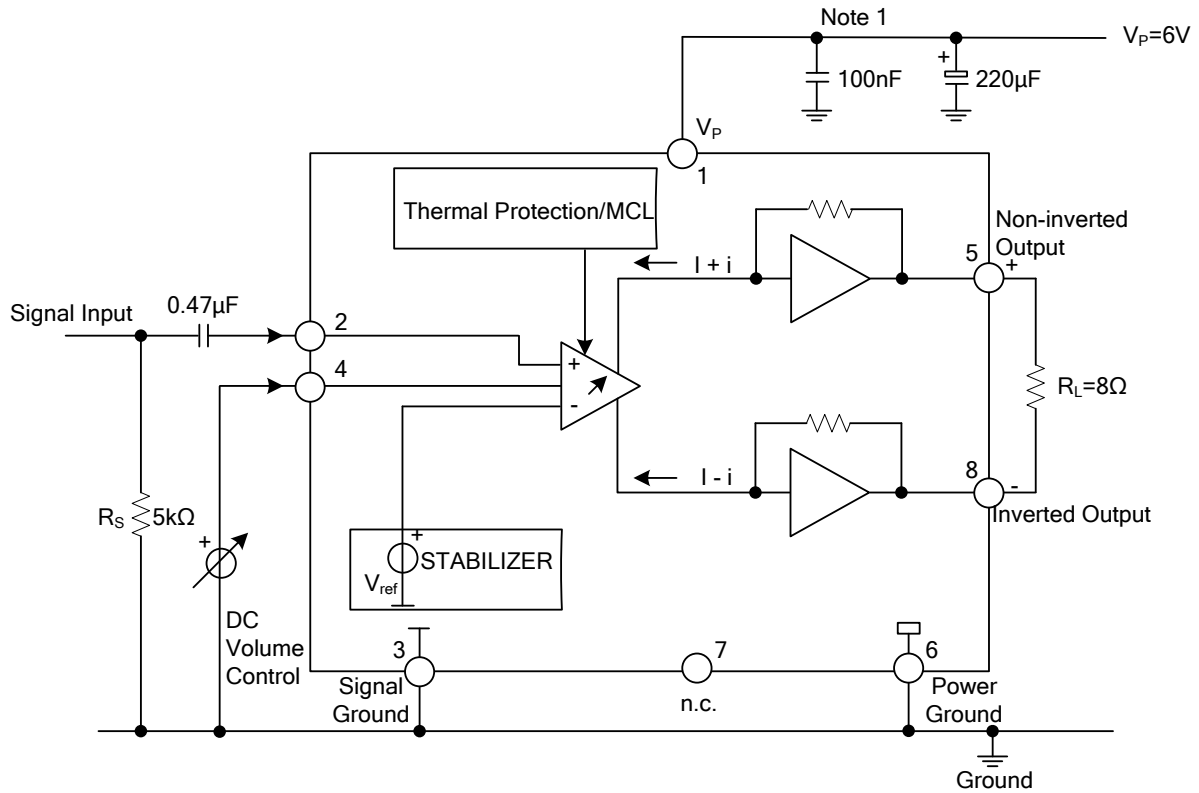

Note 1. This capacitor can be omitted if the 220μF electrolytic capacitor is connected close to pin 1.

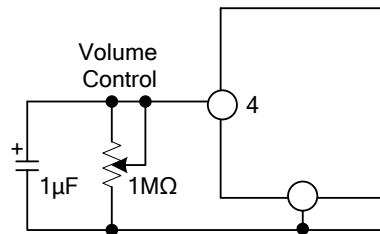

Application with potentiometer as volume control; maximum gain=30dB

■ TYPICAL CHARACTERISTICS

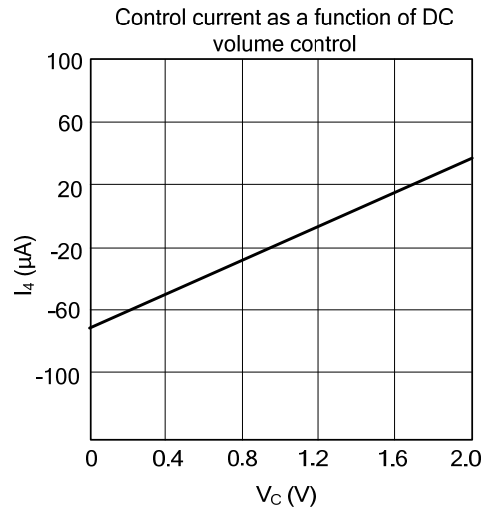
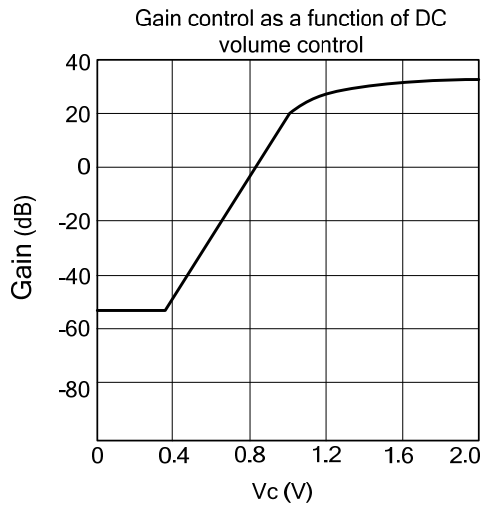

UTC assumes no responsibility for equipment failures that result from using products at values that exceed, even momentarily, rated values (such as maximum ratings, operating condition ranges, or other parameters) listed in products specifications of any and all UTC products described or contained herein. UTC products are not designed for use in life support appliances, devices or systems where malfunction of these products can be reasonably expected to result in personal injury. Reproduction in whole or in part is prohibited without the prior written consent of the copyright owner. The information presented in this document does not form part of any quotation or contract, is believed to be accurate and reliable and may be changed without notice.

X-ON Electronics

Largest Supplier of Electrical and Electronic Components

Click to view similar products for [Audio Amplifiers](#) category:

Click to view products by [Unisonic](#) manufacturer:

Other Similar products are found below :

[LV47002P-E](#) [MP7747DQ-LF-P](#) [AZ386MTR-E1](#) [NCP2811AFCT1G](#) [NCP2890AFCT2G](#) [NJM8068RB1-TE1](#) [NJV1194V-TE1](#) [LA4282-E](#)
[LA4814JA-AE](#) [LC706200CM](#) [SSM2377ACBZ-R7](#) [FDA2100LV](#) [TDA2541](#) [TDA7385H](#) [TDA7391LV](#) [TDA7575BPDTR](#) [TDA7718NTR](#)
[IS31AP2121-LQLS1](#) [IS31AP4915A-QFLS2-TR](#) [LA74309FA-BH](#) [421067X](#) [480263C](#) [NCP2820FCT2G](#) [STPA001](#) [TDA1515AQ](#) [TDA1520B](#)
[TDA1591T](#) [TDA2051H](#) [TDA4850](#) [TDA7391PDUTR](#) [TDA7563BH](#) [TDA7718B](#) [LA4425F-E](#) [LA4742-E](#) [TDA7391PDU](#)
[TDA7491MV13TR](#) [TDA749213TR](#) [TDA7563AH](#) [TDA7850H](#) [STK433-070GN-E](#) [E-TDA7391PDTR](#) [SSM2529ACBZ-R7](#) [SSM2518CBZ-](#)
[R7](#) [MAX9890BEBL+T](#) [MAX98303EWE+T](#) [MAX98358EWL+](#) [MAX98304DEWL+T](#) [MAX97220DETE+T](#) [TS4962MEIJT](#) [TS4990EIJT](#)