



TDA7265

LINEAR INTEGRATED CIRCUIT

25W+25W STEREO AMPLIFIER WITH MUTE & STAND-BY

DESCRIPTION

The UTC **TDA7265** is a stereo 25+25W class AB Dual Audio Power amplifier with mute and ST-BY control. This IC provides high output power of 25 watts per channel (at $V_{CC}=\pm 20V$, $f=1KHz$, $THD=10\%$, $R_L = 8 \Omega$). It has low I_Q at stand-by mode and no POP at turn ON or OFF.

FEATURES

- * High output power: $P_{OUT} = 25 W/channel$ (Typ.)
 $V_{CC} = \pm 20V$, $R_L = 8\Omega$, $f = 1KHz$, $THD = 10\%$
- * Operation supply voltage range ($T_A = 25^\circ C$)
 $V_{CC(OPER)} = \pm 5 \sim \pm 25V$ ($R_L = 8 \Omega$)
 $V_{CC(OPER)} = \pm 5 \sim \pm 18V$ ($R_L = 4 \Omega$)
- * Split supply
- * Built in overload protection circuit.
- * Built in thermal shut down protector circuit.
- * Built in audio muting circuit (POP free)
- * Built in standby circuit.

ORDERING INFORMATION

Ordering Number		Package	Packing
Lead Free	Halogen Free		
TDA7265L-J11-A-T	TDA7265G-J11-A-T	HZIP-11A	Tube

<p>TDA7265G-J11-A-T</p> <p>(1) Packing Type (2) Package Type (3) Green Package</p>	<p>(1) T: Tube (2) J11-A: HZIP-11A (3) G: Halogen Free and Lead Free, L: Lead Free</p>
--------------------------------------------------------------------------------------------	------------------------------------------------------------------------------------------------

MARKING

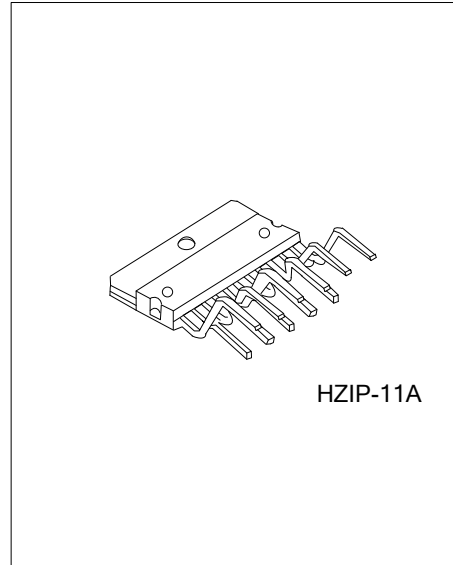
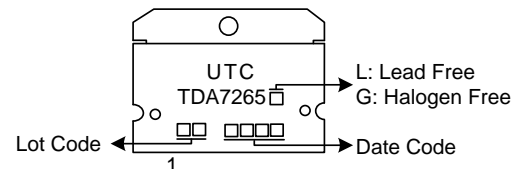

■ PIN CONFIGURATION

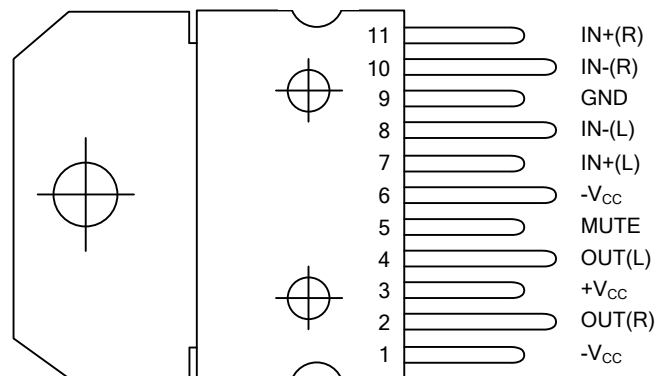

■ PIN DESCRIPTION

PIN NO.	PIN NAME	DESCRIPTION
1	$-V_{CC}$	Negative supply
2	OUT(R)	Output(right)
3	$+V_{CC}$	Positive Supply voltage
4	OUT(L)	Output(left)
5	MUTE	Mute/standby switch input
6	$-V_{CC}$	Negative supply
7	IN+(L)	non-inverting input(left)
8	IN-(L)	inverting input(left)
9	GND	Ground
10	IN-(R)	inverting input(right)
11	IN+(R)	non-inverting input(right)

■ BLOCK DIAGRAM

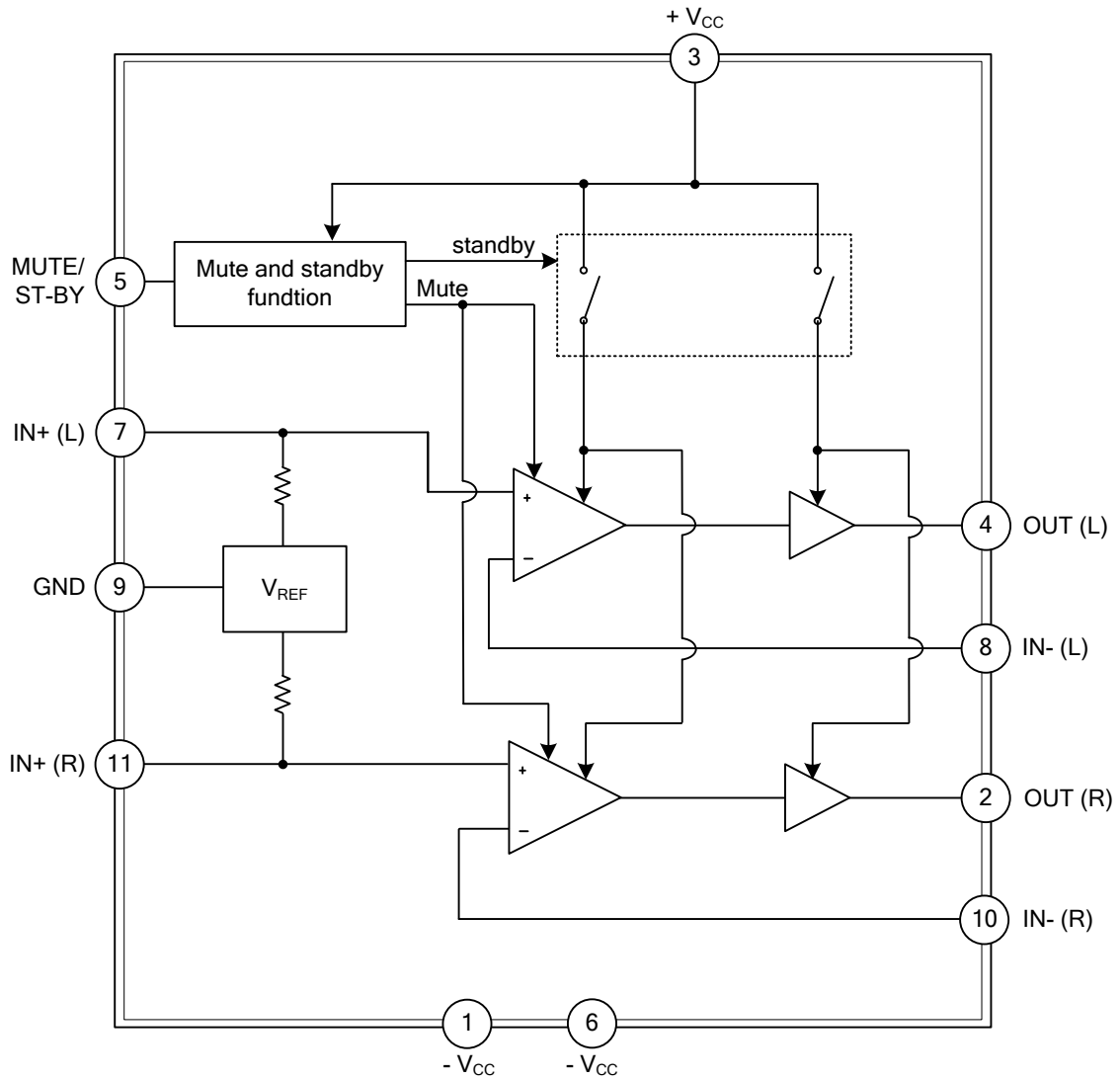

■ ABSOLUTE MAXIMUM RATING

PARAMETER	SYMBOL	RATINGS	UNIT
DC Supply Voltage	V_{CC}	± 25	V
Output Power Current (internally limited)	I_{OUT}	4.5	A
Power Dissipation ($T_C=70^\circ\text{C}$)	P_D	30	W
Junction Temperature	T_J	+150	$^\circ\text{C}$
Operating Temperature	T_{OPR}	-20 ~ +85	$^\circ\text{C}$
Storage Temperature	T_{STG}	-40 ~ +150	$^\circ\text{C}$

Note: Absolute maximum ratings are those values beyond which the device could be permanently damaged. Absolute maximum ratings are stress ratings only and functional device operation is not implied.

■ THERMAL DATA

PARAMETER	SYMBOL	RATING	UNIT
Junction to Case	θ_{JC}	2	$^\circ\text{C/W}$

■ ELECTRICAL CHARACTERISTICS

($V_{CC} = \pm 20\text{V}$, $R_L = 8\Omega$, $R_S = 50\Omega$, $G_V = 30\text{dB}$, $f = 1\text{KHz}$, $T_A = 25^\circ\text{C}$, unless otherwise specified)

PARAMETER	SYMBOL	TEST CONDITION	MIN	TYP	MAX	UNIT
Supply Voltage Range	V_{CC}		± 5		± 25	V
Total Quiescent Current	I_Q			80	130	mA
INPUT SECTION						
Input Offset Voltage	$V_{I(OFF)}$		-20		20	mV
Bias Current	I_{BIAS}			500		nA
Input Resistance	R_{IN}		15	20		K Ω
OUTPUT SECTION						
Output Power	P_{OUT}	THD=10%	$V_{CC} = \pm 20\text{V}$, $R_L = 8\Omega$	20	25	W
			$V_{CC} = \pm 16\text{V}$, $R_L = 4\Omega$		25	W
		THD = 1%	$V_{CC} = \pm 20\text{V}$, $R_L = 8\Omega$		20	W
			$V_{CC} = \pm 16\text{V}$, $R_L = 4\Omega$		20	W
Total Harmonic Distortion	THD	$R_L = 8\Omega$, $P_{OUT} = 1\text{W}$, $f = 1\text{KHz}$		0.01		%
		$R_L = 8\Omega$, $P_{OUT} = 0.1 \sim 15\text{W}$, $f = 100\text{Hz} \sim 15\text{KHz}$			0.7	%
		$R_L = 4\Omega$, $P_{OUT} = 1\text{W}$, $f = 1\text{KHz}$		0.02		%
		$R_L = 4\Omega$, $V_{CC} = \pm 16\text{V}$, $P_{OUT} = 0.1 \sim 12\text{W}$, $f = 100\text{Hz} \sim 15\text{KHz}$			1	%
Cross Talk	C_T	$f = 1\text{KHz}$		70		dB
		$f = 10\text{KHz}$		60		dB
Slew Rate	SR			10		V/ μs
Open Loop Voltage Gain	G_{VO}			80		dB
Total Output Noise	eN	A Curve		3		μV
		$f = 20\text{Hz}$ to 22KHz		4	8	μV
Supply Voltage Rejection (each channel)	SVR	$f = 100\text{Hz}$, $V_R = 0.5\text{V}$		60		dB
THERMAL PROTECTION						
Thermal Shut-down Junction Temperature	T_J			145		$^\circ\text{C}$
MUTE FUNCTION						
Mute /Play Threshold	V_{T_MUTE}		-7	-6	-5	V
Mute Attenuation	A_{MUTE}		60	70		dB
STAND-BY FUNCTIONS						
Stand-by Mute threshold	V_{T_ST-BY}		-3.5	-2.5	-1.5	V
Stand-by Attenuation	A_{ST-BY}			110		dB
Quiescent Current (Stand-by)	$I_{Q(ST-BY)}$			3		mA

■ TYPICAL APPLICATION CIRCUIT

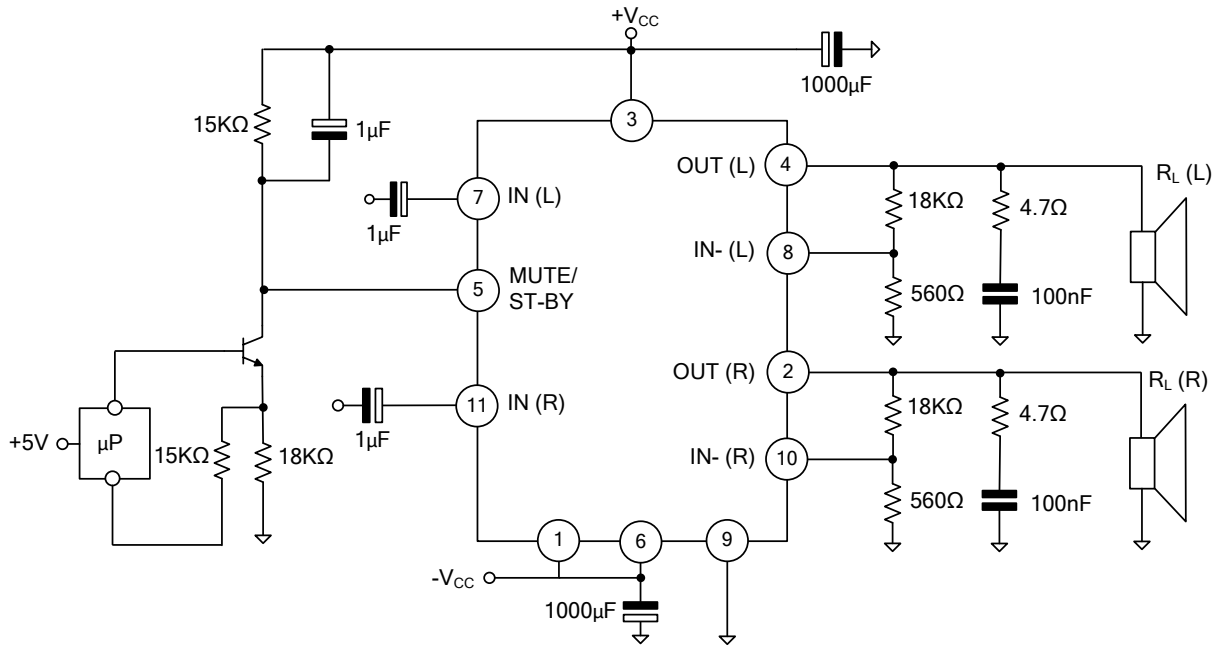

Typical Application Circuit

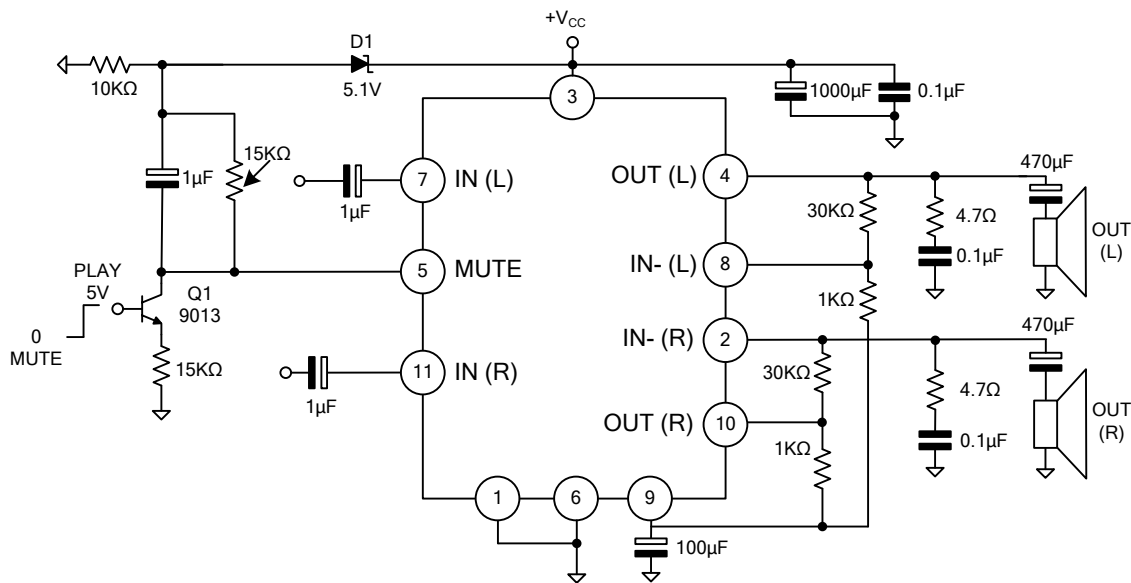

Single Supply Application

■ TYPICAL APPLICATION CIRCUIT (Cont.)

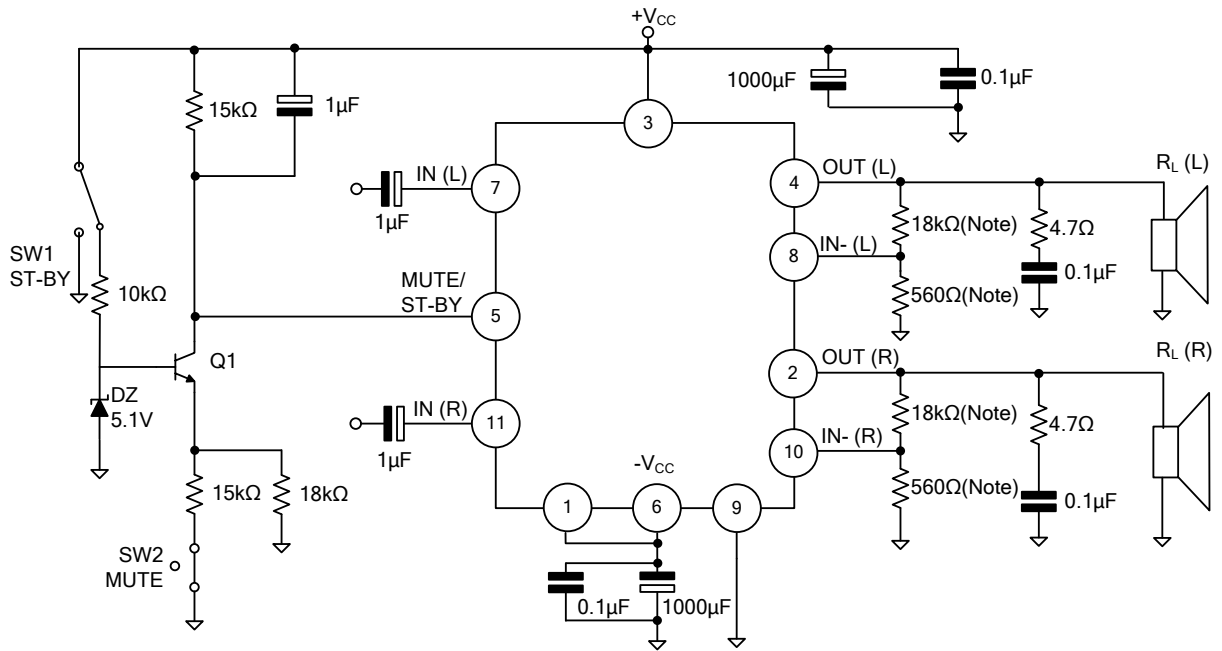

Note: Closed loop gain has to be $\geq 25\text{dB}$

Test and Application Circuit (Stereo Configuration)

■ MUTE STAND-BY FUNCTION

The pin 5 (MUTE/STAND-BY) controls the amplifier status by two different thresholds, referred to $+V_{CC}$.

V_{PIN5}	Amplifier Status
$+V_{CC} > V_{PIN5} \geq +V_{CC} - 2.5V$	Stand-by Mode
$+V_{CC} - 2.5V > V_{PIN5} > +V_{CC} - 6V$	Mute Mode
$V_{PIN5} \leq +V_{CC} - 6V$	Play Mode

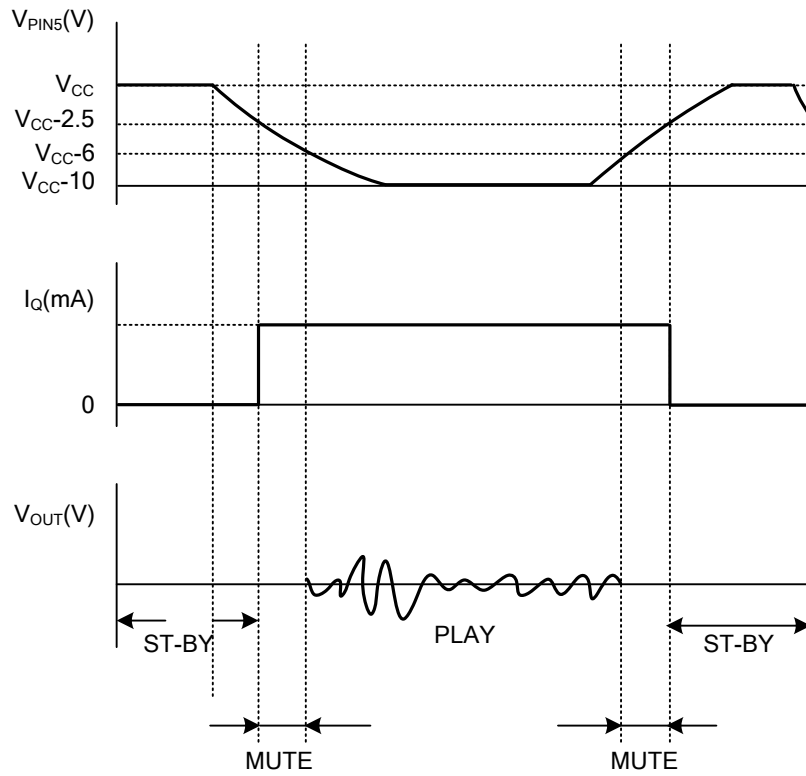

■ TYPICAL CHARACTERISTICS

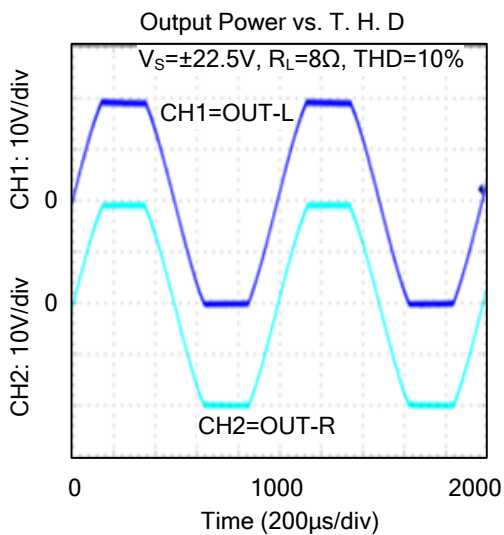
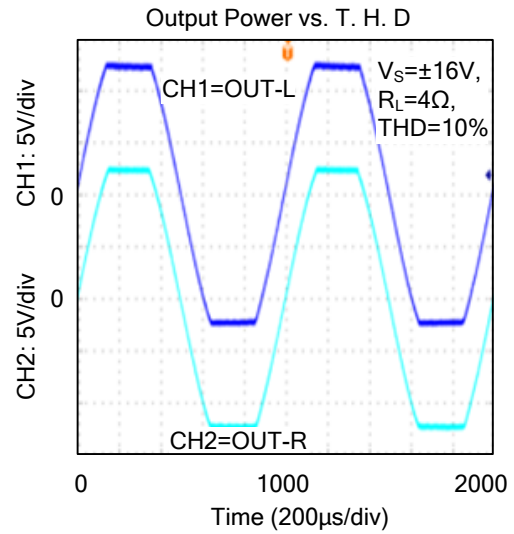
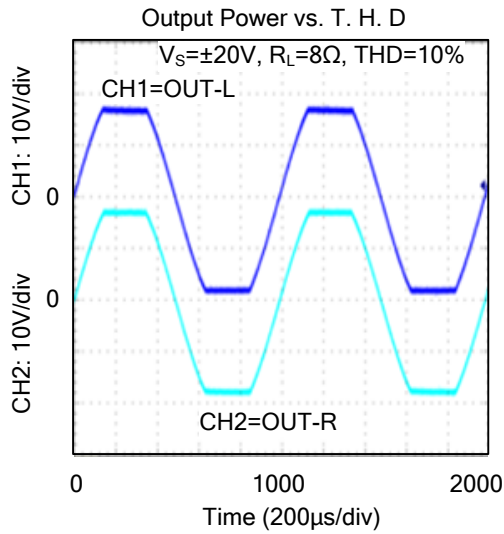

UTC assumes no responsibility for equipment failures that result from using products at values that exceed, even momentarily, rated values (such as maximum ratings, operating condition ranges, or other parameters) listed in products specifications of any and all UTC products described or contained herein. UTC products are not designed for use in life support appliances, devices or systems where malfunction of these products can be reasonably expected to result in personal injury. Reproduction in whole or in part is prohibited without the prior written consent of the copyright owner. UTC reserves the right to make changes to information published in this document, including without limitation specifications and product descriptions, at any time and without notice. This document supersedes and replaces all information supplied prior to the publication hereof.

X-ON Electronics

Largest Supplier of Electrical and Electronic Components

Click to view similar products for [Audio Amplifiers](#) category:

Click to view products by [Unisonic](#) manufacturer:

Other Similar products are found below :

[LV47002P-E](#) [AZ386MTR-E1](#) [NCP2890AFCT2G](#) [LC706200CM](#) [IS31AP4915A-QFLS2-TR](#) [TDA1591T](#) [TS2012EIJT](#) [NCP2809BMUTXG](#)
[NJW1157BFC2](#) [IS31AP4996-GRLS2-TR](#) [NCP2823BFCT1G](#) [BD88420GUL-E2](#) [LA4450L-E](#) [IS31AP2036A-CLS2-TR](#) [TDA7563ASMTR](#)
[BD88400GUL-E2](#) [BD88200GUL-E2](#) [SABRE9601K](#) [THAT1646W16-U](#) [PAM8965ZLA40-13](#) [TSDP10XX1NLGXZBX](#)
[TSDP11XX1NGBIZBX](#) [TSDP10XX1NGBIZBX](#) [NJM4580CV-TE1](#) [TPA3223DDVR](#) [LV4910T-MPB-E](#) [NCP2890AFCT2](#) [NCV2211DR2G](#)
[SCY99091FCT2G](#) [COS6112](#) [LM4890SS](#) [LM4871](#) [NS4890C](#) [AW8010BFCR](#) [COS4812](#) [MC34018M/TR](#) [LM4890MM/TR](#) [ME5301ASPG](#)
[LM386M-1](#) [TAS5720MRSMR](#) [BL6281GMM](#) [BL6281GSO](#) [CS3818EO](#) [CS3817BEO](#) [CS3815EO](#) [LM4861BM/TR](#) [TDA2822N](#)
[MC34118M/TR](#) [LM4871BM/TR](#) [LM1875TB](#)