



TIP41C

NPN PLANAR TRANSISTOR

NPN EXPITAXIAL PLANAR TRANSISTOR

■ DESCRIPTION

The UTC **TIP41C** is a NPN expitaxial planar transistor, designed for using in general purpose amplifier and switching applications.

■ FEATURE

* Complement to TIP42C

■ SYMBOL

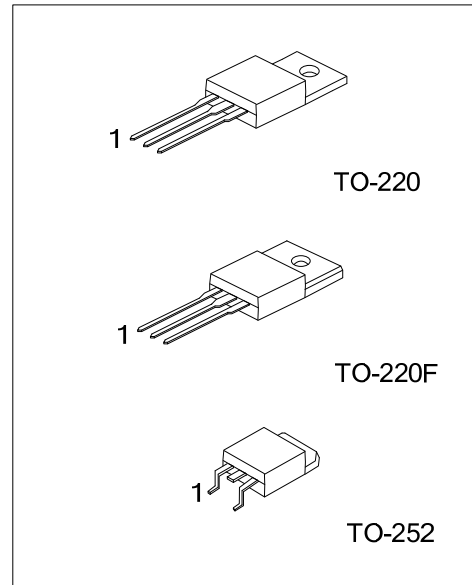
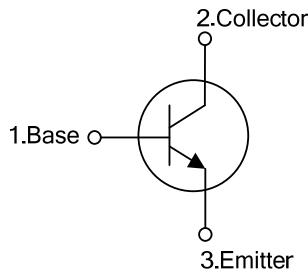

■ ORDERING INFORMATION

Ordering Number		Package	Pin Assignment			Packing
Lead Free	Halogen Free		1	2	3	
TIP41CL-x-TA3-T	TIP41CG-x-TA3-T	TO-220	B	C	E	Tube
TIP41CL-x-TF3-T	TIP41CG-x-TF3-T	TO-220F	B	C	E	Tube
TIP41CL-x-TN3-T	TIP41CG-x-TN3-T	TO-252	B	C	E	Tube
TIP41CL-x-TN3-R	TIP41CG-x-TN3-R	TO-252	B	C	E	Tape Reel

Note: Pin Assignment: B: Base C: Collector E: Emitter

<p>TIP41CL-x-TA3-T</p>	<p>(1) T: Tube, R: Tape Reel</p> <p>(2) TA3: TO-220, TF3: TO-220F, TN3: TO-252</p> <p>(3) x: refer to Classification of h_{FE2}</p> <p>(4) L: Lead Free, G: Halogen Free and Lead Free</p>
------------------------	---

■ MARKING

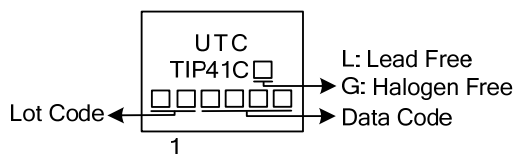

TIP41C

NPN PLANAR TRANSISTOR

■ ABSOLUTE MAXIMUM RATINGS ($T_C=25^\circ\text{C}$, unless otherwise specified)

PARAMETER		SYMBOL	RATING	UNIT
Collector Base Voltage		V_{CBO}	100	V
Collector to Emitter Voltage		V_{CEO}	100	V
Emitter-Base Voltage		V_{EBO}	5	V
Collector Current	DC	I_C	6	A
	Pulse		10	A
Base Current		I_B	2	A
Collector Dissipation	$T_C=25^\circ\text{C}$	TO-220	65	W
		TO-220F	22	
		TO-252	25	
	$T_A=25^\circ\text{C}$	TO-220	2	W
		TO-220F	0.7	
		TO-252	0.75	

Note: Absolute maximum ratings are those values beyond which the device could be permanently damaged. Absolute maximum ratings are stress ratings only and functional device operation is not implied.

■ ELECTRICAL CHARACTERISTICS ($T_C=25^\circ\text{C}$, unless otherwise specified)

PARAMETER	SYMBOL	TEST CONDITIONS	MIN	TYP	MAX	UNIT
Emitter Base Breakdown Voltage	BV_{EBO}	$I_E=100\mu\text{A}, I_C=0$	5			V
Collector Base Breakdown Voltage	BV_{CBO}	$I_C=100\mu\text{A}, I_E=0$	100			V
Collector Emitter Sustaining Voltage (Note)	BV_{CEO}	$I_C=30\text{mA}, I_B=0$	100			V
Collector Cutoff Current	I_{CEO}	$V_{CE}=60\text{V}, I_B=0$			0.7	mA
Collector Cutoff Current	I_{CES}	$V_{CE}=100\text{V}, V_{EB}=0$			400	μA
Emitter Cutoff Current	I_{EBO}	$V_{EB}=5\text{V}, I_C=0$			1	mA
Collector-Emitter Saturation Voltage (Note)	$V_{CE(SAT)}$	$I_C=6\text{A}, I_B=600\text{mA}$			1.5	V
Base-Emitter On Voltage (Note)	$V_{BE(ON)}$	$I_C=6\text{A}, V_{CE}=4\text{V}$			2.0	V
DC Current Gain (Note)	h_{FE1}	$I_C=300\text{mA}, V_{CE}=4\text{V}$	30			
	h_{FE2}	$I_C=3\text{A}, V_{CE}=4\text{V}$	15		75	
Current Gain Bandwidth Product	f_T	$V_{CE}=10\text{V}, I_C=500\text{mA}, f=1\text{MHz}$	3			MHz

Note: Pulse Test: $P_w \leq 300\mu\text{s}$, Duty Cycle $\leq 2\%$

■ CLASSIFICATION OF h_{FE2}

RANK	A	B	C
RANGE	15~30	28~48	45~75

TYPICAL CHARACTERISTICS

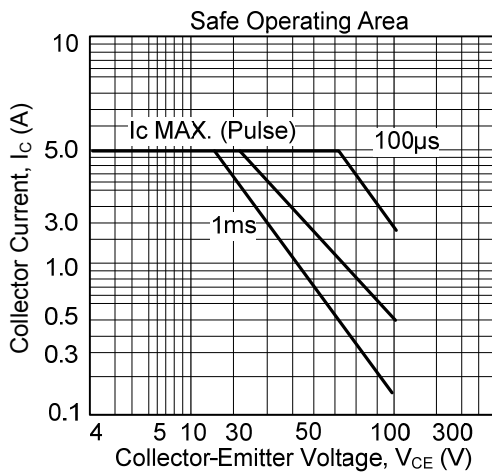
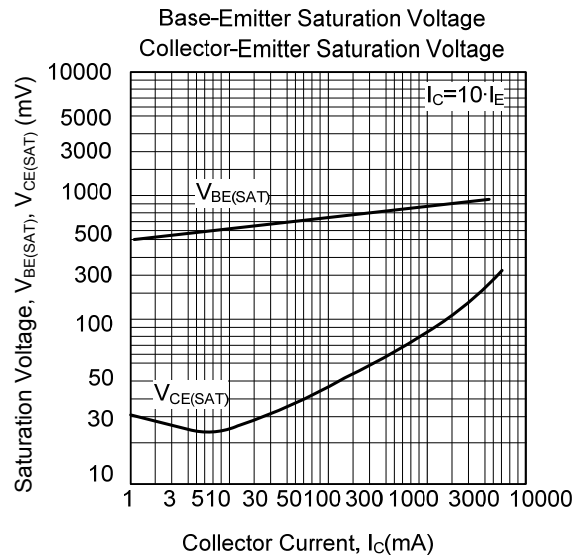
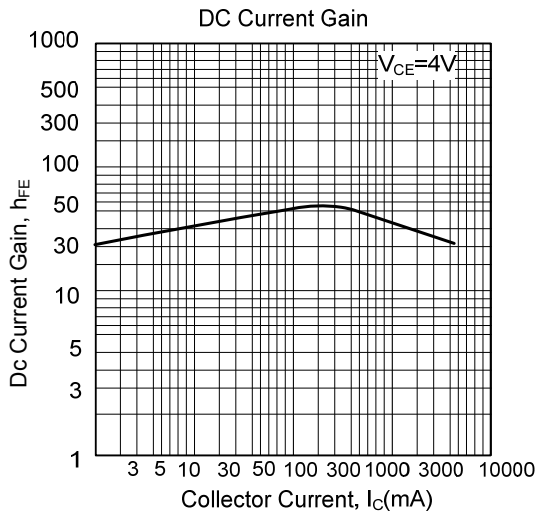

UTC assumes no responsibility for equipment failures that result from using products at values that exceed, even momentarily, rated values (such as maximum ratings, operating condition ranges, or other parameters) listed in products specifications of any and all UTC products described or contained herein. UTC products are not designed for use in life support appliances, devices or systems where malfunction of these products can be reasonably expected to result in personal injury. Reproduction in whole or in part is prohibited without the prior written consent of the copyright owner. The information presented in this document does not form part of any quotation or contract, is believed to be accurate and reliable and may be changed without notice.

X-ON Electronics

Largest Supplier of Electrical and Electronic Components

Click to view similar products for [Bipolar Transistors - BJT category](#):

Click to view products by [Unisonic manufacturer](#):

Other Similar products are found below :

[619691C](#) [MCH4017-TL-H](#) [MMBT-2369-TR](#) [BC546/116](#) [BC557/116](#) [BSW67A](#) [NJVMJD148T4G](#) [NTE123AP-10](#) [NTE153MCP](#) [NTE16](#)
[NTE195A](#) [NTE92](#) [C4460](#) [2N4401-A](#) [2N6728](#) [2SA1419T-TD-H](#) [2SA2126-E](#) [2SB1204S-TL-E](#) [2SC2712S-GR,LF](#) [2SC5488A-TL-H](#)
[2SD2150T100R](#) [SP000011176](#) [2N2907A](#) [2N3904-NS](#) [2N5769](#) [2SC2412KT146S](#) [2SD1816S-TL-E](#) [CPH6501-TL-E](#) [MCH4021-TL-E](#)
[MJE340](#) [US6T6TR](#) [NJL0281DG](#) [732314D](#) [CPH3121-TL-E](#) [CPH6021-TL-H](#) [873787E](#) [IMZ2AT108](#) [UMX21NTR](#) [MCH6102-TL-E](#)
[NJL0302DG](#) [2N3583](#) [30A02MH-TL-E](#) [NSV40301MZ4T1G](#) [NTE13](#) [NTE26](#) [NTE282](#) [NTE323](#) [NTE350](#) [NTE81](#) [STX83003-AP](#)