



## TL594

## LINEAR INTEGRATED CIRCUIT

### PULSE-WIDTH-MODULATION CONTROL CIRCUIT

#### DESCRIPTION

The UTC **TL594** is a PWM (Pulse Width Modulation) control circuit, incorporating two error amplifiers, an on-chip adjustable oscillator, a DTC (Deadtime Control) comparator, a pulse-steering control flip-flop, a regulator rated 5V with 1% accuracy, an UVLO (Undervoltage Lockout) control circuit and an output control circuit.

The two error amplifiers have a common-mode voltage varies from -0.3 V to  $V_{CC}-2$  V. The DTC comparator with a fixed-offset offers dead time nearly 5%. The UVLO circuit forbids the output until the internal circuitry is operational. The internal oscillator is used to drive the common circuits in synchronous multiple-rail power supplies, when be bypassed by terminating RT to the reference output and providing an external input of sawtooth to CT.

The uncommitted output transistors have the capabilities of either common-emitter or emitter-follower output. The output control can select the push-pull or single-ended output operation for each device. This chip is not allowed to appear the double pulse status for either output during push-pull output operation due to its structure.

The UTC **TL594** is generally used for the power supply control circuits, which apply to a large area.

#### FEATURES

- \* Adjustable dead time
- \* Uncommitted outputs transistor rated to 200mA sink or source current
- \* Single-Ended or Push-Pull operation selected by output control
- \* Double pulse is not allowed at either output due to its architecture
- \* 5V Internal reference voltage (1% accuracy)
- \* UVLO under the low  $V_{CC}$  status

#### ORDERING INFORMATION

Order Number		Package	Packing
Lead Free	Halogen Free		
TL594L-D16-T	TL594G-D16-T	DIP-16	Tube
-	TL594G-S16-R	SOP-16	Tape Reel

<p>TL594L-D16-T</p> <p>(1)Packing Type (2)Package Type (3)Green Package</p>	<p>(1) R: Tape Reel, T: Tube (2) D16: DIP-16, S16: SOP-16 (3) L: Lead Free, G: Halogen Free and Lead Free</p>
---	---

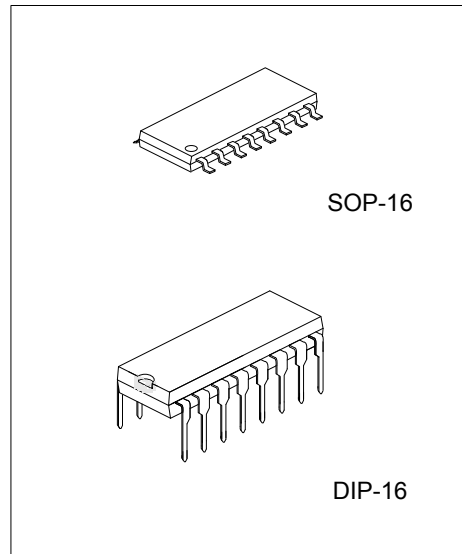

### MARKING

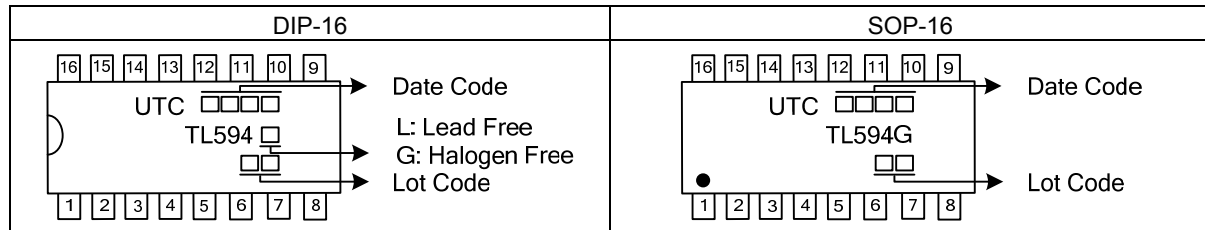

### PIN CONFIGURATION

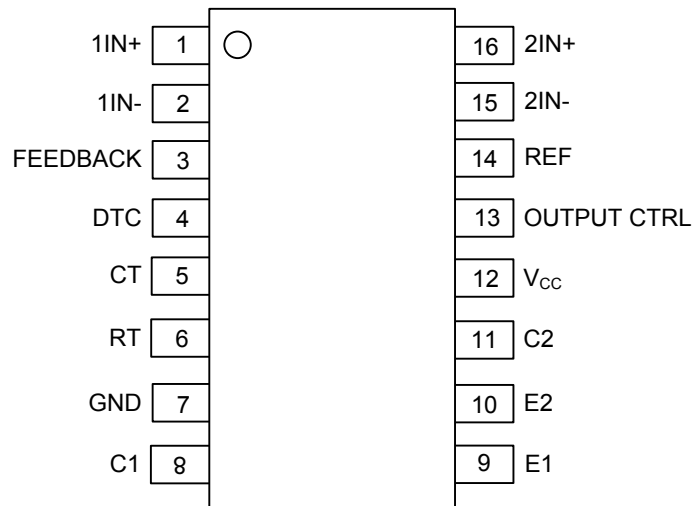

PIN NO	PIN NAME	DESCRIPTION
1	1IN+	The noninv input of error amp 1
2	1IN-	The inv input of error amp 1
3	REEDBACK	Input of Feedback PWM Comparator
4	DTC	The deadtime can be set by changing the voltage of this pin
5	CT	A capacitor connected to this pin sets the fixed switching frequency
6	RT	A resistor connected to this pin sets the fixed switching frequency
7	GND	This is gnd pin
8	C1	Collector of output transistors Q1
9	E1	Emitter of output transistors Q1
10	E2	Emitter of output transistors Q2
11	C2	Collector of output transistors Q2
12	VCC	This pin is connected to the IC supply power.
13	Output CTRL	A external signal connect to this pin can control the state of output
14	REF	Internal reference voltage 5V with 1.5% accuracy
15	2IN-	The inv input of error amp 2
16	2IN+	The noninv input of error amp 2

## ■ BLOCK DIAGRAM

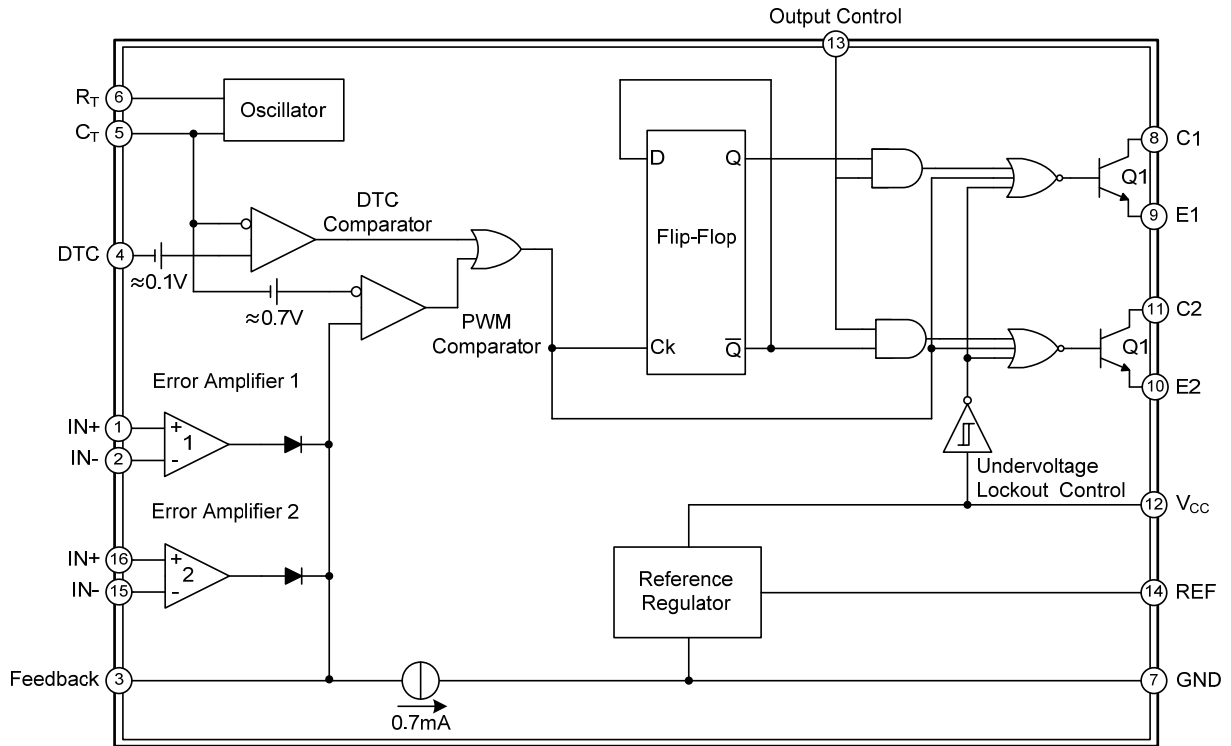

## ■ FUNCTION TABLE

INPUT	OUTPUT FUNCTION
Output CTRL	
$V_I = 0$	Single-Ended or Parallel Output
$V_I = V_{REF}$	Normal Push-Pull Operation

### ■ ABSOLUTE MAXIMUM RATINGS (unless otherwise specified)

PARAMETER	SYMBOL	RATINGS	UNIT
Supply Voltage	$V_{CC}$	41	V
Amplifier Input Voltage	$V_{IN}$	$V_{CC} + 0.3$	V
Collector Output Voltage	$V_{C1}, V_{C2}$	41	V
Collector Output Current	$I_{C1}, I_{C2}$	250	mA
Junction Temperature	$T_J$	+150	°C
Operating Temperature	$T_{OPR}$	-40 ~ +85	°C
Storage Temperature	$T_{STG}$	-65 ~ +150	°C

Note: Absolute maximum ratings are those values beyond which the device could be permanently damaged. Absolute maximum ratings are stress ratings only and functional device operation is not implied.

### ■ THERMAL DATA

PARAMETER	SYMBOL	RATINGS	UNIT
Junction to Ambient (Note)	DIP-16	$\theta_{JA}$	°C/W
	SOP-16		
		67	
		64	

Note: Maximum power dissipation is a function of  $T_{J(MAX)}$ ,  $\theta_{JA}$ , and  $T_a$ . The maximum allowable power dissipation at any allowable ambient temperature is  $P_D = (T_{J(MAX)} - T_a) / \theta_{JA}$ . Operating at the absolute maximum  $T_J$  of 150°C can affect reliability.

### ■ RECOMMENDED OPERATING CONDITIONS

PARAMETER	SYMBOL	MIN	TYP.	MAX	UNIT
Supply Voltage	$V_{CC}$	7		40	V
Amplifier Input Voltage	$V_{IN}$	-0.3		$V_{CC} - 2$	V
Collector Output Voltage	$V_{C1}, V_{C2}$			40	V
Collector Output Current (Each Transistor)	$I_{C1}, I_{C2}$			200	mA
Current Into Feedback Terminal	$I_{FB}$			0.3	mA
Timing Capacitor	$C_T$	0.47		10000	nF
Timing Resistor	$R_T$	1.8		500	kΩ
Oscillator Frequency	$f_{OSC}$	1		300	kHz

### ■ ELECTRICAL CHARACTERISTICS ( $V_{CC}=15V$ , unless otherwise specified)

PARAMETER	SYMBOL	TEST CONDITIONS	MIN	TYP	MAX	UNIT
<b>REFERENCE SECTION</b>						
Output Voltage (REF)	$V_{REF}$	$I_{OUT} = 1mA, T_a = 25^\circ C$	4.95	5	5.05	V
Input Regulation	$\Delta V_{OUT}$	$V_{CC} = 7V \sim 40V, T_a = 25^\circ C$		2	25	mV
Output Regulation	$\Delta V_{OUT}$	$I_{OUT} = 1 \sim 10mA, T_a = 25^\circ C$		14	35	mV
Output-Voltage Change with Temperature		$\Delta T_a = \text{Min} \sim \text{Max}$		2	10	mV/V
Short-Circuit Output Current (Note)	$I_{SC}$	$V_{REF} = 0V$	10	35	50	mA
<b>OSCILLATOR SECTION, <math>C_T = 0.01\mu F, R_T = 12K\Omega</math> (See Figure 1)</b>						
Frequency	$f_{OSC}$			10		kHz
Standard Deviation of Frequency (Note)	$\sigma f_{OSC}$	All values of $V_{CC}, C_T, R_T,$ and $T_a$ constant		100		Hz/kHz
Frequency Change With Voltage	$\Delta f_{OSC}(\Delta V)$	$V_{CC} = 7V \sim 40V, T_a = 25^\circ C$		1		Hz/kHz
Frequency Change With Temperature	$\Delta f_{OSC}(\Delta T)$	$\Delta T_a = \text{Min} \sim \text{Max}$			50	Hz/kHz
<b>DEAD-TIME CONTROL SECTION (See Figure 1)</b>						
Input Bias Current	$I_{IB(DT)}$	$V_{IN} = 0 \sim 5.25V$		-2	-10	μA
Maximum Duty Cycle, Each Output	$DC_{MAX}$	$DTC = 0V$	0.45			
Input Threshold Voltage	$V_{TH}$	Zero Duty Cycle		3	3.3	V
		Maximum Duty Cycle	0			V

### ■ ELECTRICAL CHARACTERISTICS(Cont.)

PARAMETER	SYMBOL	TEST CONDITIONS	MIN	TYP	MAX	UNIT	
<b>OUTPUT SECTION</b>							
Collector-Emitter Saturation Voltage	Common Emitter	$V_{SAT(C)}$	$V_E=0, I_C=200mA$		1.1	1.3	V
	Emitter Follower	$V_{SAT(E)}$	$V_C=15V, I_E=-200mA$		1.5	2.5	V
Collector Off-State Current	$I_{C(OFF)}$	DTC and Output CTRL = 0V, $V_C=15V, V_E=0V, V_{CC}=1\sim 3V$	$V_C=40V, V_E=0V, V_{CC}=40V$		2	100	$\mu A$
					4	200	$\mu A$
Emitter Off-State Current	$I_{E(OFF)}$	$V_{CC}=V_C=40V, V_E=0$			-100	$\mu A$	
Output Control Input Current	$I_{OC}$	$V_{IN}=V_{REF}$			3.5	mA	
<b>PWM COMPARATOR SECTION (See Figure 1)</b>							
Input Threshold Voltage	$V_{TH}$	Zero duty cycle		4	4.5	V	
Input Sink Current	$I_{I(SINK)}$	FEEDBACK = 0.5V	0.3	0.7		mA	
<b>UNDERVOLTAGE LOCKOUT SECTION (See Figure 1)</b>							
Threshold Voltage	$V_{TH}$	$T_a = 25^\circ C$			6	V	
		$\Delta T_a = \text{Min} \sim \text{Max}$	3.5		6.9	V	
Hysteresis	$V_{HYS}$		100			mV	
<b>OVERALL DEVICE</b>							
Standby Supply Current	$I_{STN-BY}$	$R_T$ at $V_{REF}$ All Other Inputs And Outputs Open	$V_{CC} = 15V$		9	15	mA
			$V_{CC} = 40V$		11	18	mA
Average Supply Current		DTC = 2V, See Figure 1		12.4		mA	
<b>AMPLIFIER SECTION (See Figure 2)</b>							
Input Offset Voltage, Error Amplifier	$V_{I(OFF)}$	FEEDBACK = 2.5V		2	10	mV	
Input Offset Current	$I_{I(OFF)}$	FEEDBACK = 2.5V		25	250	nA	
Input Bias Current	$I_{IB}$	FEEDBACK = 2.5V		0.2	1	$\mu A$	
Common-Mode Input Voltage Range, Error Amplifier	$V_{ICR}$	$V_{CC}=7V\sim 40V$	0.3 to $V_{CC}-2$			V	
Open-Loop Voltage Amplification Gain, Error Amplifier	$A_{VOL}$	$\Delta V_{OUT}=3V, R_L=2k\Omega,$ $V_{OUT} = 0.5V\sim 3.5V$	70	95		dB	
Unity-Gain Bandwidth	$B_W$	$V_{OUT} = 0.5V \sim 3.5V, R_L=2k\Omega$		800		kHz	
Common-Mode Rejection Ratio, Error Amplifier	CMRR	$V_{CC} = 40V, T_a=25^\circ C$	65	80		dB	
Output Sink Current, FEEDBACK	$I_{O(SINK)}$	$V_{ID} = -15mV\sim -5V,$ FEEDBACK = 0.5V	0.3	0.7		mA	
Output Source Current, FEEDBACK	$I_{O(SOURCE)}$	$V_{ID} = 15mV\sim 5V,$ FEEDBACK = 3.5V	-2			mA	
<b>SWITCHING CHARACTERISTICS, <math>T_a = 25^\circ C</math></b>							
Output-Voltage Rise Time	$T_r$	Emitter-Follower Configuration (see Figure 3)		200	400	ns	
Output-Voltage Fall Time	$T_f$			45	100	ns	
Output-Voltage Rise Time	$T_r$	Common-Emitter Configuration (see Figure 4)		100	200	ns	
Output-Voltage Fall Time	$T_f$			30	100	ns	

Note: Standard deviation is a measure of the statistical distribution about the mean, as derived from the formula:

$$\sigma = \sqrt{\frac{\sum_{n=1}^N (X_n - \bar{X})^2}{N-1}}$$

■ PARAMETER MEASUREMENT INFORMATION

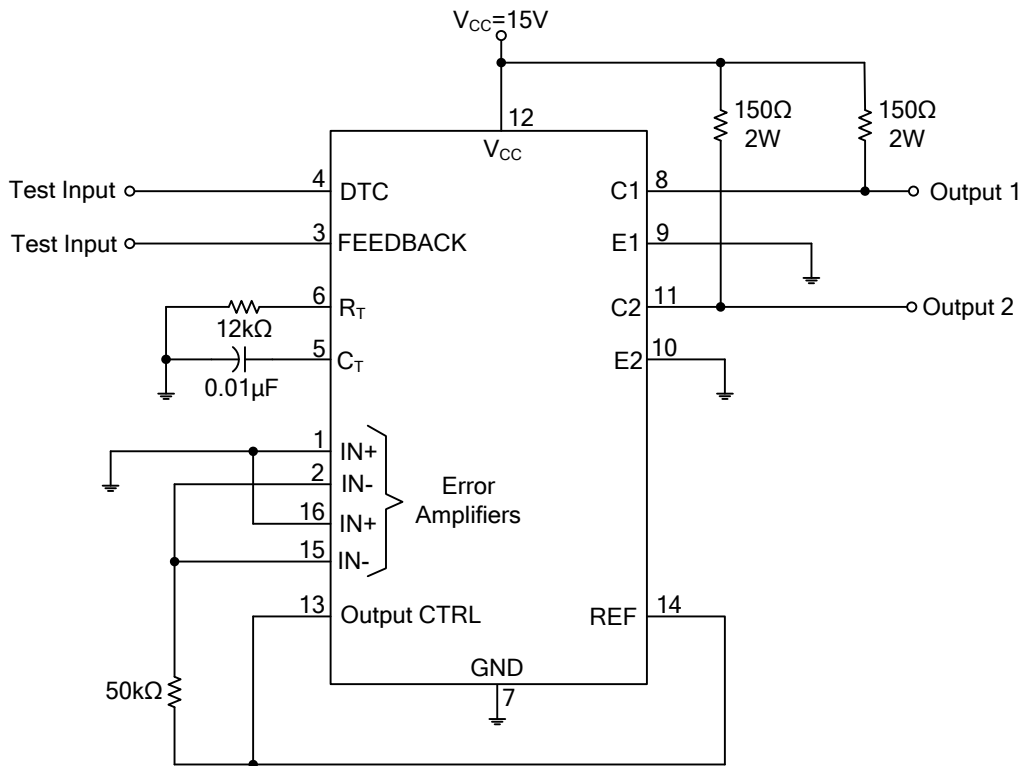

Figure 1. Operational Test Circuit

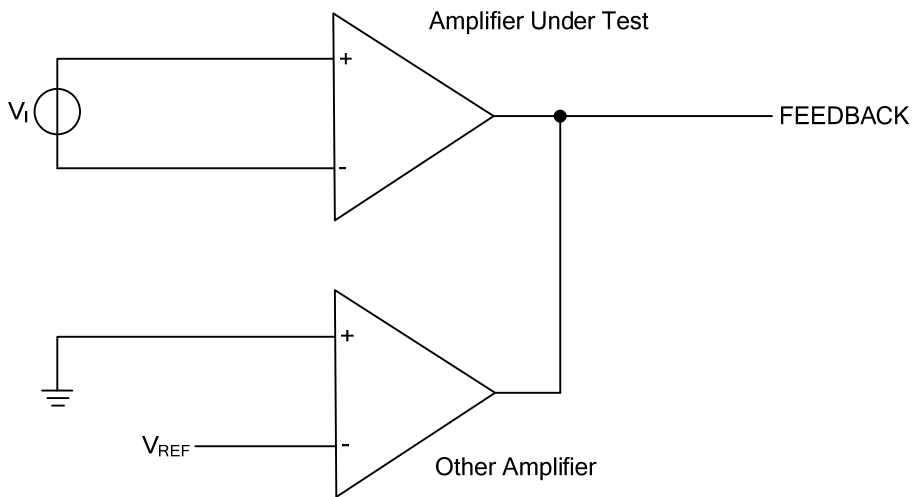

Figure 2. Amplifier-Characteristics Test Circuit

■ PARAMETER MEASUREMENT INFORMATION(Cont.)

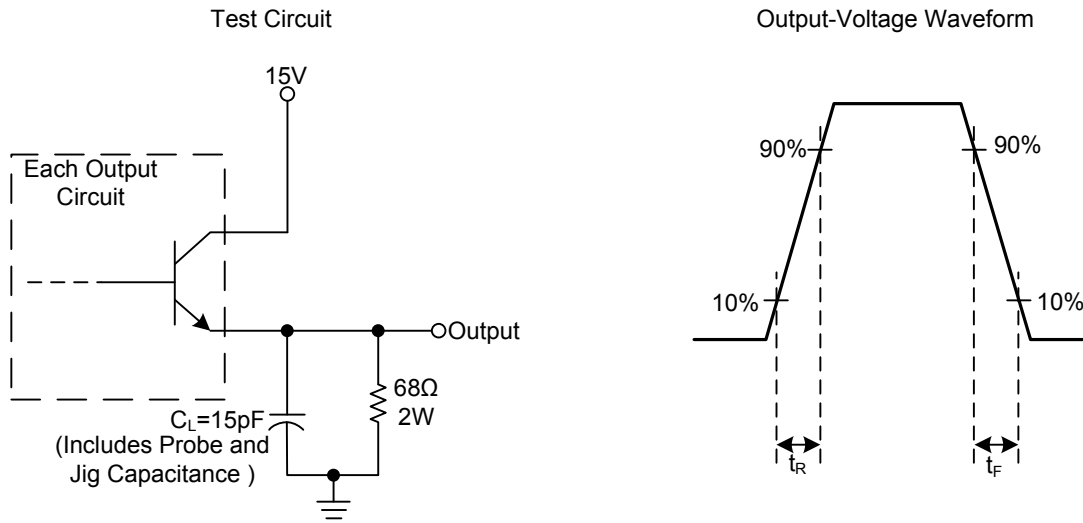

Figure 3. Emitter-Follower Configuration

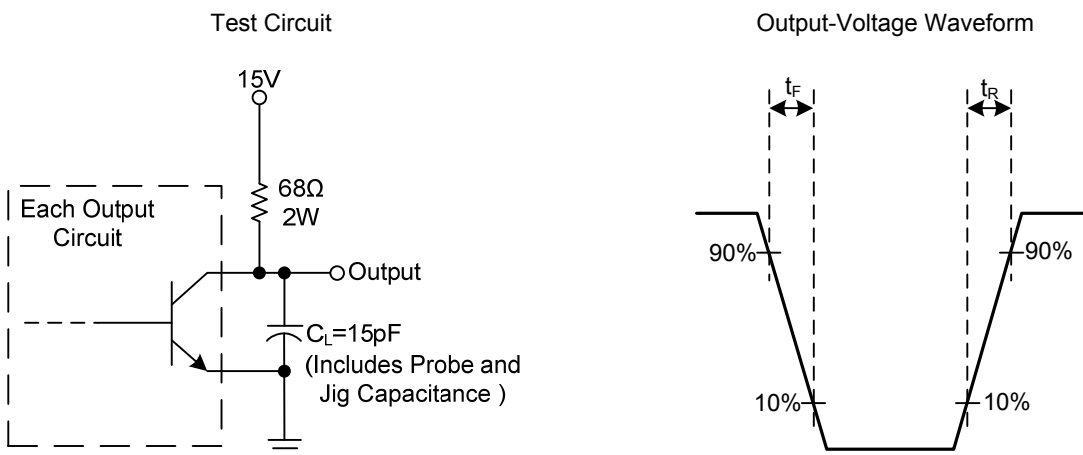
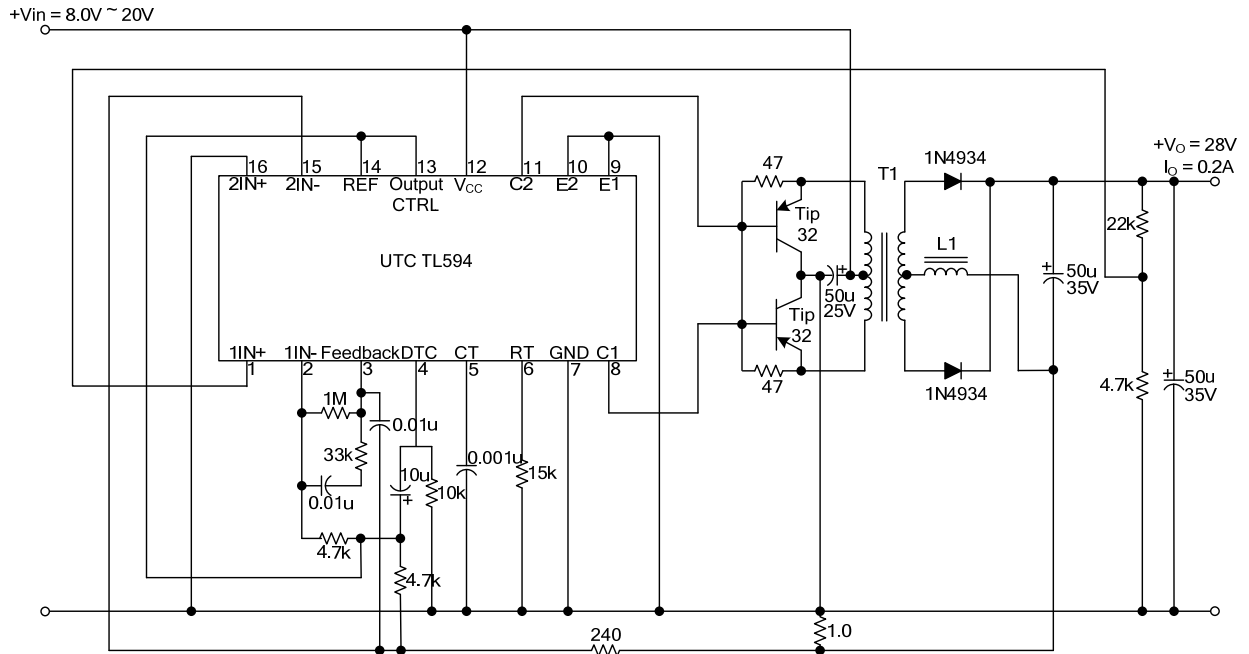

Figure 4. Common-Emitter Configuration

## TYPICAL APPLICATIONS INFORMATION



Note: All capacitors in  $\mu F$

### Push-Pull Operation

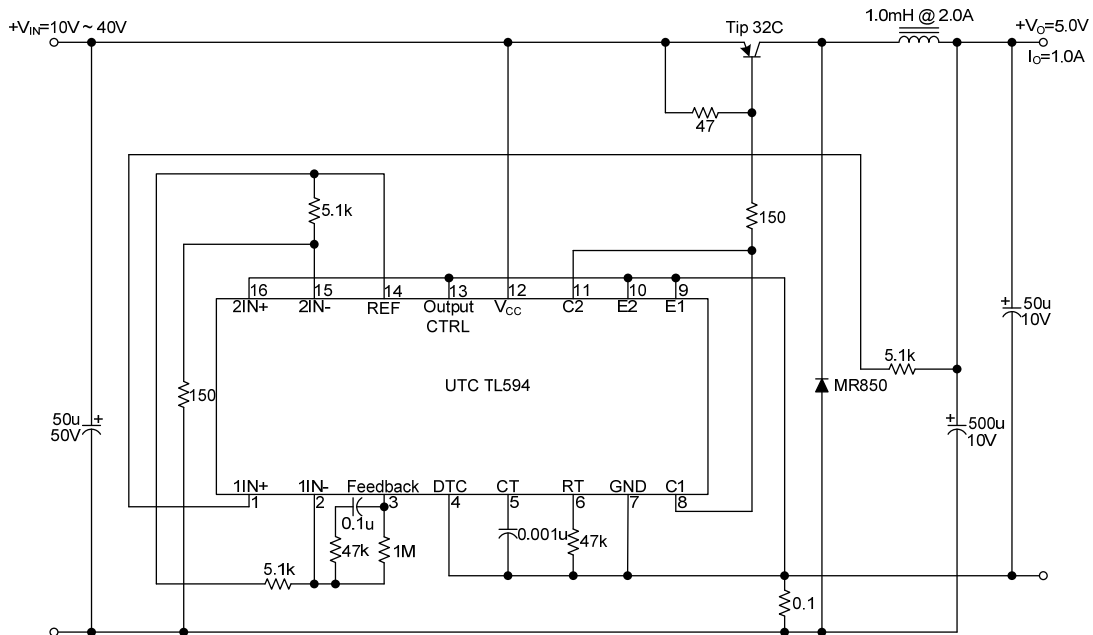

### Single-Ended Operation



■ TYPICAL CHARACTERISTIC

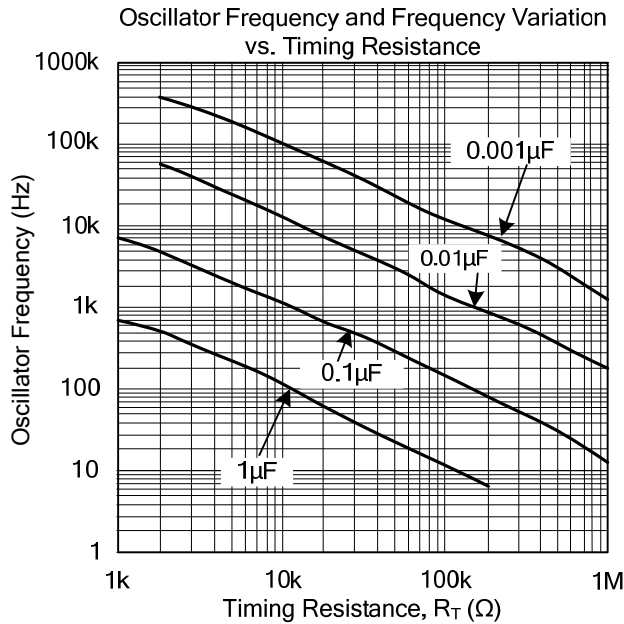

Note: Frequency variation ( $\Delta f$ ) is the change in oscillator frequency that occurs over the full temperature range.

UTC assumes no responsibility for equipment failures that result from using products at values that exceed, even momentarily, rated values (such as maximum ratings, operating condition ranges, or other parameters) listed in products specifications of any and all UTC products described or contained herein. UTC products are not designed for use in life support appliances, devices or systems where malfunction of these products can be reasonably expected to result in personal injury. Reproduction in whole or in part is prohibited without the prior written consent of the copyright owner. The information presented in this document does not form part of any quotation or contract, is believed to be accurate and reliable and may be changed without notice.

## X-ON Electronics

Largest Supplier of Electrical and Electronic Components

*Click to view similar products for [Linear Voltage Regulators](#) category:*

*Click to view products by [Unisonic](#) manufacturer:*

Other Similar products are found below :

[LV5684PVD-XH](#) [MCDTSA6-2R](#) [L7815ACV-DG](#) [LV56801P-E](#) [UA7805CKC](#) [714954EB](#) [ZMR500QFTA](#) [BA033LBSG2-TR](#)  
[NCV78M05ABDTRKG](#) [LV5680P-E](#) [L79M05T-E](#) [L78LR05D-MA-E](#) [NCV317MBTG](#) [NTE7227](#) [MP2018GZD-33-P](#) [MP2018GZD-5-P](#)  
[LV5680NPVC-XH](#) [ZTS6538SE](#) [UA78L09CLP](#) [UA78L09CLPR](#) [CAT6221-PPTD-GT3](#) [MC78M09CDTRK](#) [NCV51190MNTAG](#)  
[BL1118CS8TR1833](#) [BL8077CKETR33](#) [BL9153-33CC3TR](#) [BL9161G-28BADRN](#) [BRCO7530MMC](#) [CJ7815B-TFN-ARG](#) [LM317C](#)  
[GM7333K](#) [GM7350K](#) [XC6206P332MR](#) [HT7533](#) [LM7912S/TR](#) [LT1764S/TR](#) [LM7805T](#) [LM338T](#) [LM1117IMP-3.3/TR](#) [HT1117AM-3.3](#)  
[HT7550S](#) [AMS1117-3.3](#) [HT7150S](#) [78L12](#) [HT7550](#) [HT7533-1](#) [HXY6206I-2.5](#) [HT7133](#) [HT7533S](#) [662K](#)