



U3525

LINEAR INTEGRATED CIRCUIT

REGULATING PWM IC

DESCRIPTION

The UTC **U3525** is a pulse width modulator IC and designed for switching power supplies application to improve performance and reduce external parts usage.

A shutdown terminal controls both the soft-start circuitry and the output stages, providing instantaneous turn off through the PWM latch with pulsed shutdown, as well as soft-start recycle with longer shutdown commands. The output stage features NOR logic, giving a LOW output for an OFF state. An under-voltage lockout circuitry, which keeps the outputs off and the soft-start capacitor discharged for sub-normal input voltages, includes approximately 500 mV of hysteresis for jitter free operation. The PWM circuits also feature a latch following the comparator. When a PWM pulses has been terminated, the outputs will remain off for the duration of the period. The latch is reset with each clock pulse. The output stages are totem-pole designs capable of sourcing or sinking in excess of 200mA.

FEATURES

- * Input Voltage: 8~35V
- * On-chip +5.1V reference is trimmed to $\pm 1\%$
- * 100HZ ~ 400KHZ oscillator range
- * Separate oscillator sync terminal
- * Adjustable dead time control
- * Internal soft-start
- * Pulse-by-pulse shutdown
- * Input under-voltage lockout with hysteresis
- * Latching PWM to prevent multiple pulses
- * Dual source/sink output drivers

ORDERING INFORMATION

Ordering Number		Package	Packing
Lead Free	Halogen Free		
U3525L-D16-T	U3525G-D16-T	DIP-16	Tube
U3525L-S16-R	U3525G-S16-R	SOP-16	Tape Reel
U3525L-S16W-R	U3525G-S16W-R	SOP-16W	Tape Reel
U3525L-S16N-R	U3525G-S16N-R	SOP-16N	Tape Reel

<p>U3525G-D16-T</p> <p>(1) Packing Type</p> <p>(2) Package Type</p> <p>(3) Green Package</p>	<p>(1) R: Tape Reel, T: Tube</p> <p>(2) D16: DIP-16, S16: SOP-16, S16W: SOP-16W S16N: SOP-16N</p> <p>(3) G: Halogen Free and Lead Free, L: Lead Free</p>
--	--

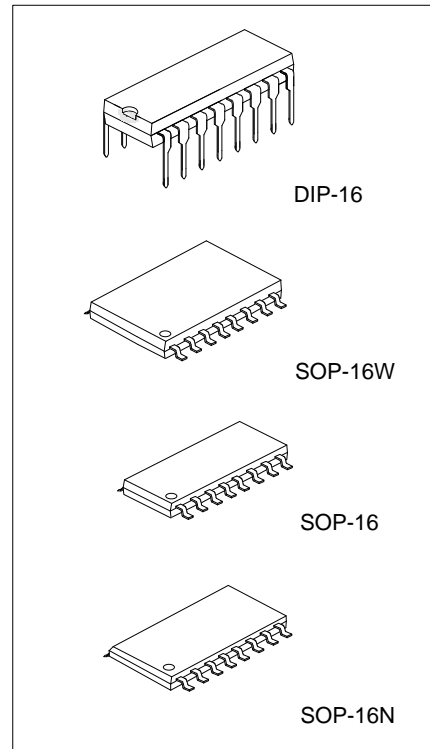

MARKING

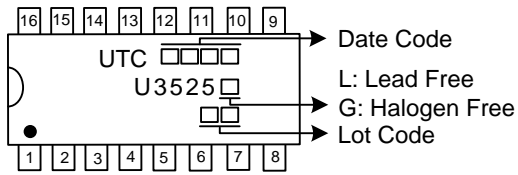

PIN CONNECTIONS (top view)

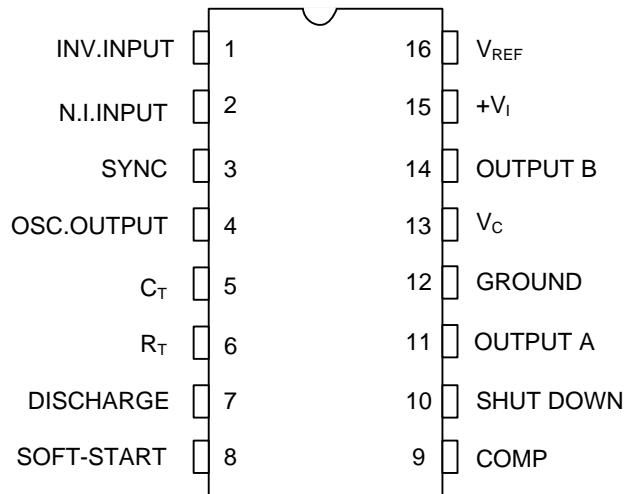

■ BLOCK DIAGRAM

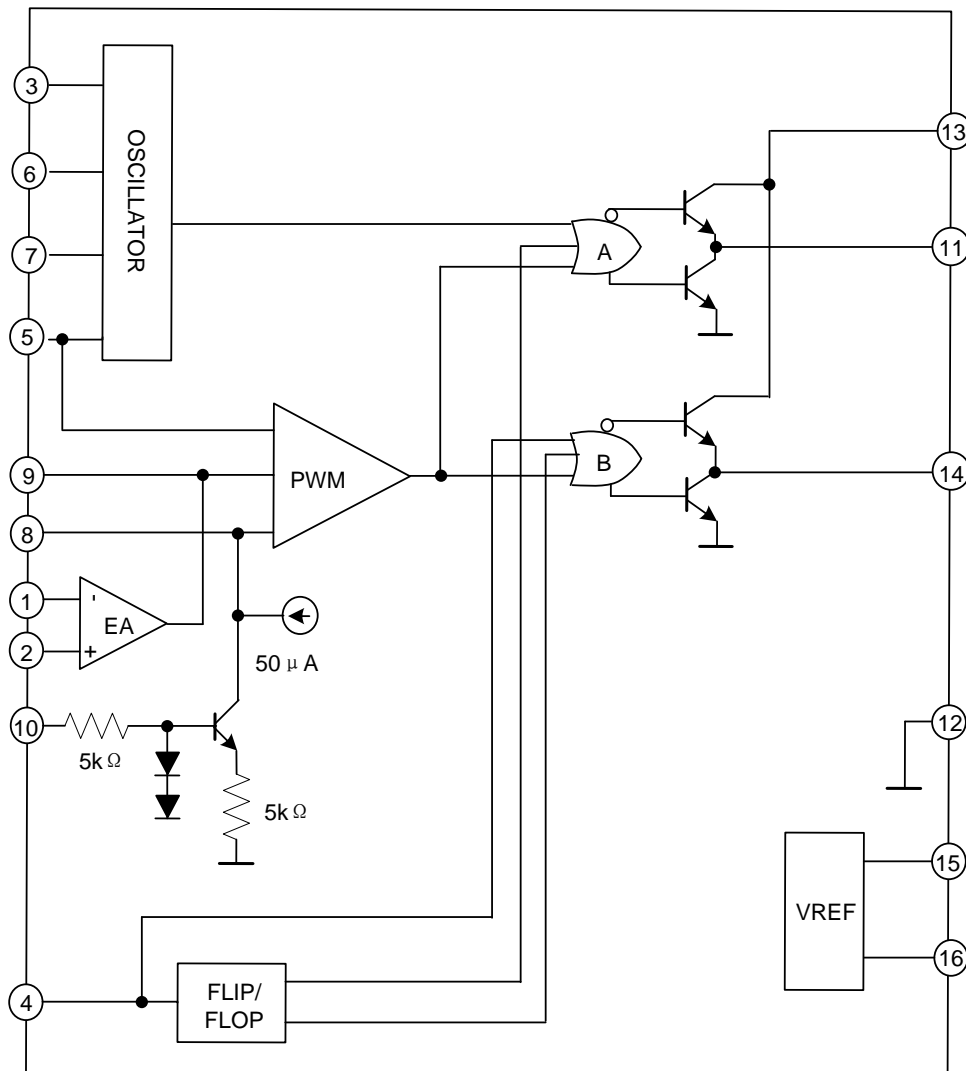

■ ABSOLUTE MAXIMUM RATINGS

PARAMETER	SYMBOL	RATINGS	UNIT
Supply Voltage	V_{IN}	40	V
Collector Supply Voltage	V_C	40	V
Oscillator Charging Current	I_{OSC}	5	mA
Output Current, Source or Sink	I_O	500	mA
Reference Output Current	I_R	50	mA
Current through C_T Terminal		5	mA
Logic Inputs	I_T	- 0.3 ~ + 5.5	V
Analog Inputs		-0.3 ~ V_i	V
Total Power Dissipation at $T_a=70\text{ }^\circ\text{C}$	P_D	1000	mW
Junction Temperature	T_J	-55 ~ +125	$^\circ\text{C}$
Operating Ambient Temperature	T_{ORP}	0 ~ +70	$^\circ\text{C}$
Storage Temperature	T_{STG}	-65 ~ +150	$^\circ\text{C}$

Note: Absolute maximum ratings are those values beyond which the device could be permanently damaged. Absolute maximum ratings are stress ratings only and functional device operation is not implied.

■ RECOMMENDED OPERATING CONDITIONS (NOTE)

PARAMETER	SYMBOL	RATINGS	UNIT
Input Voltage	V_{IN}	8 ~ 35	V
Collector Supply Voltage	V_C	4.5 ~ 35	V
Sink/Source Load Current (steady state)	I_{STEAD}	0 ~ 100	mA
Sink/Source Load Current (peak)	I_{PEAK}	0 ~ 400	mA
Reference Load Current	I_{LOAD}	0 ~ 20	mA
Oscillator Frequency Range	F_O	100 ~ 400K	Hz
Oscillator Timing Resistor	R_O	2 ~ 150	K Ω
Oscillator Timing Capacitor	C_O	0.001 ~ 0.1	μF
Dead Time Resistor Range	R_T	0 ~ 500	Ω

Note: Range over which the device is functional and parameter limits are guaranteed.

■ THERMAL DATA

PARAMETER	SYMBOL	RATING	UNIT	
Thermal Resistance Junction-ambient	DIP16	θ_{JA}	80	$^\circ\text{C/W}$
	SOP-16	θ_{JA}	50	$^\circ\text{C/W}$
	SOP-16N			
	SOP-16W			

Note: Thermal resistance junction-alumina with the device soldered on the middle of an alumina supporting substrate measuring 15x20 mm; 0.65 mm thickness with infinite heat sink.

■ ELECTRICAL CHARACTERISTICS ($V_{IN} = 25V$, unless otherwise specified)

PARAMETER	SYMBOL	TEST CONDITIONS	MIN	TYP	MAX	UNIT
REFERENCE SECTION						
Output Voltage	V_{REF}	$T_J = 25^\circ C$	5	5.1	5.2	V
Total Output Variation (Note 1)		Line, Load and Temperature	4.95		5.25	V
Long Term Stability (Note 1)	ΔV_{REF}	$T_J = 125^\circ C$, 1000 hrs		20	50	mV
Line Regulation	ΔV_{REF}	$V_{IN} = 8 \sim 35 V$		10	20	mV
Load Regulation	ΔV_{REF}	$I_L = 0 \sim 20 mA$		20	50	mV
Temp. Stability (Note 1)	$\Delta V_{REF}/\Delta T$	Over Operating Range		20	50	mV
Output Noise Voltage (Note 1)		$10 Hz \leq f \leq 10 kHz$, $T_J = 25^\circ C$		40	200	μV_{rms}
Short Circuit Current		$V_{REF} = 0$, $T_J = 25^\circ C$		80	100	mA
OSCILLATOR SECTION						
Clock Amplitude (Note 1, 2)			3	3.5		V
Sync Threshold			1.2	2	2.8	V
Sync Input Current		Sync Voltage = 3.5 V		1	2.5	mA
Current Mirror		$I_{RT} = 2 mA$	1.7	2	2.2	mA
Maximum Frequency	f_{MAX}	$R_T = 2 K\Omega$, $C_T = 0.001 \mu F$	400			KHz
Minimum Frequency	f_{MIN}	$R_T = 150 K\Omega$, $C_T = 0.1 \mu F$			100	Hz
Clock Width (Note 1, 2)		$T_J = 25^\circ C$	0.3	0.5	1	μs
Initial Accuracy (Note 1, 2)		$T_J = 25^\circ C$		± 2	± 6	%
Voltage Stability (Note 1, 2)		$V_{IN} = 8 \sim 35 V$		± 1	± 2	%
Temperature Stability (Note 1)	$\Delta f/\Delta T$	Over Operating Range		± 3	± 6	%
ERROR AMPLIFIER SECTION ($V_{CM} = 5.1 V$)						
Output Low Level				0.2	0.5	V
Output High Level			3.8	5.6		V
Input Offset Voltage	V_{OS}			2	10	mV
Input Bias Current	I_b			1	10	μA
Input Offset Current	I_{os}				1	μA
Comm. Mode Reject.	CMR	$V_{CM} = 1.5 \sim 5.2 V$	60	75		dB
Supply Voltage Rejection	PSR	$V_{IN} = 8 \sim 35 V$	50	60		dB
DC Open Loop Gain		$R_L \geq 10 M\Omega$	60	75		dB
DC Transconduct. (Note 1, 3)		$30 K\Omega \leq R_L \leq 1 M\Omega$, $T_J = 25^\circ C$	1.1	1.5		ms
Gain Bandwidth Product (Note 1)		$G_v = 0 dB$, $T_J = 25^\circ C$	1	2		MHz
PWM COMPARATOR						
Input Threshold (Note 2)		Zero Duty-cycle	0.7	0.9		V
		Maximum Duty-cycle		3.3	3.6	V
Input Bias Current (Note 1)				0.05	1	μA
Minimum Duty-cycle					0	%
Maximum Duty-cycle (Note 2)			45	49		%
SHUTDOWN SECTION						
Soft Start Low Level		$V_{SD} = 2.5 V$		0.4	0.7	V
Shutdown Threshold		To outputs, $V_{SS} = 5.1 V$, $T_J = 25^\circ C$	0.6	0.8	1	V
Shutdown Input Current		$V_{SD} = 2.5 V$		0.4	1	mA
Soft Start Current		$V_{SD} = 0 V$, $V_{SS} = 0 V$	25	50	80	μA
Shutdown Delay (Note 1)		$V_{SD} = 2.5 V$, $T_J = 25^\circ C$		0.2	0.5	μs

■ ELECTRICAL CHARACTERISTICS (Cont.)

PARAMETER	SYMBOL	TEST CONDITIONS	MIN	TYP	MAX	UNIT
OUTPUT DRIVERS (each output) (V_C = 20 V)						
Output Low Level		I _{SINK} = 20 mA		0.2	0.4	V
		I _{SINK} = 100 mA		1	2	V
Output High Level		I _{SOURCE} = 20 mA	18	19		V
		I _{SOURCE} = 100 mA	17	18		V
Under-Voltage Lockout		V _{COMP} and V _{SS} = High	6	7	8	V
Collector Leakage	I _C	V _C = 35 V			200	μA
Rise Time (Note 1)	t _R	C _L = 1 nF, T _J = 25°C		100	600	ns
Fall Time (Note 1)	t _F	C _L = 1 nF, T _J = 25°C		50	300	ns
TOTAL STANDBY CURRENT						
Supply Current	I _S	V _{IN} = 35 V		14	20	mA

Notes: 1. The parameters are not 100% tested in production.

2. Tested at f_{osc}=40 KHz (R_T=3.6 KΩ, C_T=10nF, R_D=0 Ω). Approximate oscillator frequency is defined by :

$$f = \frac{1}{C_T(0.7R_T + 3R_D)}$$

3. DC transconductance (g_M) relates to DC open-loop voltage gain (G_V) according to the following equation:
G_V=g_M R_L where R_L is the resistance from pin 9 to ground. The minimum g_M specification is used to calculate minimum G_V when the error amplifier output is loaded.

TEST CIRCUIT

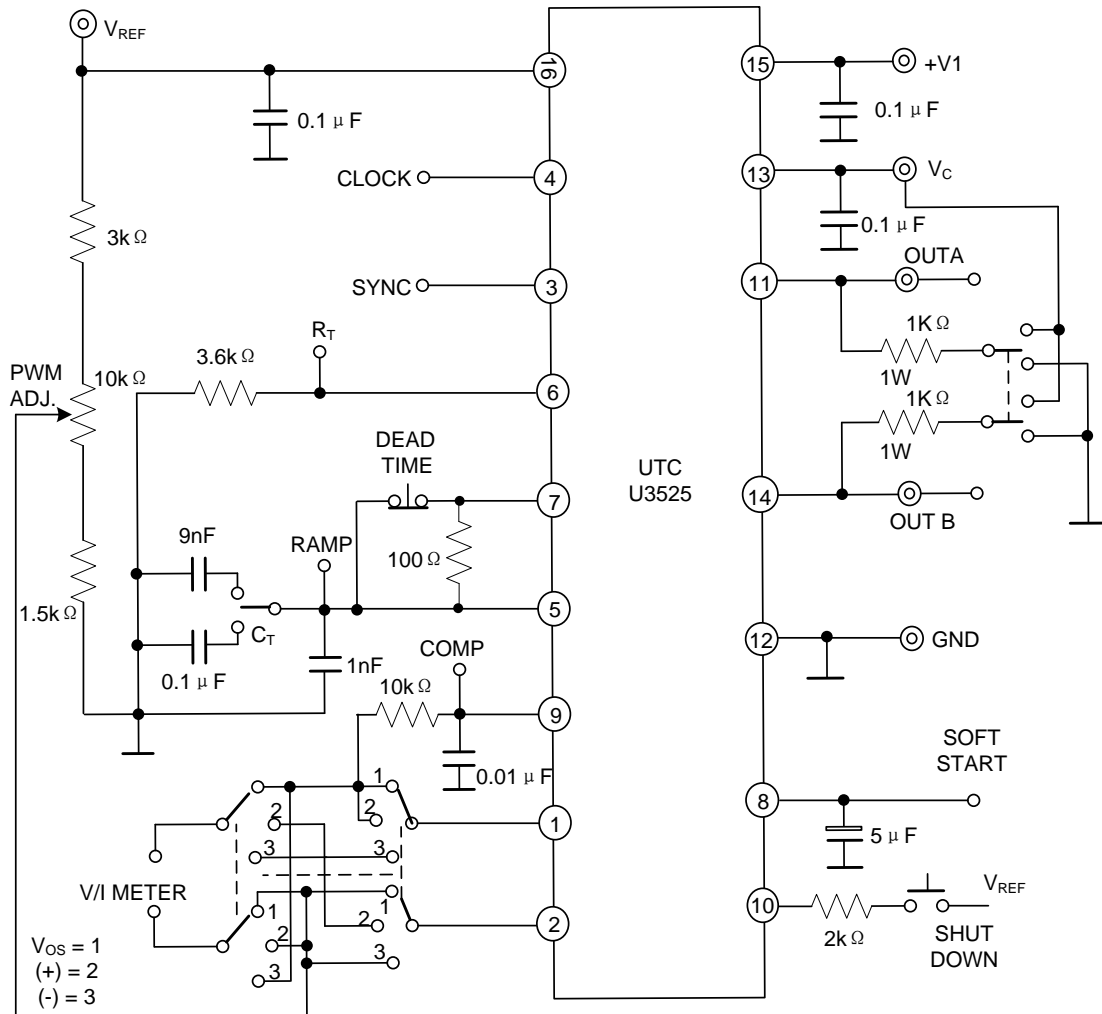

APPLICATION INFORMATION AND CIRCUIT

SHUTDOWN OPTIONS (see Block Diagram)

Since both the compensation and soft-start terminals (Pins 9 and 8) have current source pull-ups, either can readily accept a pull-down signal which only has to sink a maximum of 100 μ A to turn off the outputs. This is subject to the added requirement of discharging whatever external capacitance may be attached to these pins.

An alternate approach is the use of the shutdown circuitry of Pin 10 which has been improved to enhance the available shutdown options. Activating this circuit by applying a positive signal on Pin 10 performs two functions: the PWM latch is immediately set providing the fastest turn-off signal to the outputs; and a 150 μ A current sink begins to discharge the external soft-start capacitor. If the shutdown command is short, the PWM signal is terminated without significant discharge of the soft-start capacitor, thus, allowing, for example, a convenient implementation of pulse-by-pulse current limiting. Holding Pin 10 high for a longer duration, however, will ultimately discharge this external capacitor, recycling slow turn-on upon release.

Pin 10 should not be left floating as noise pickup could conceivably interrupt normal operation.

OSCILLATOR SCHEMATIC

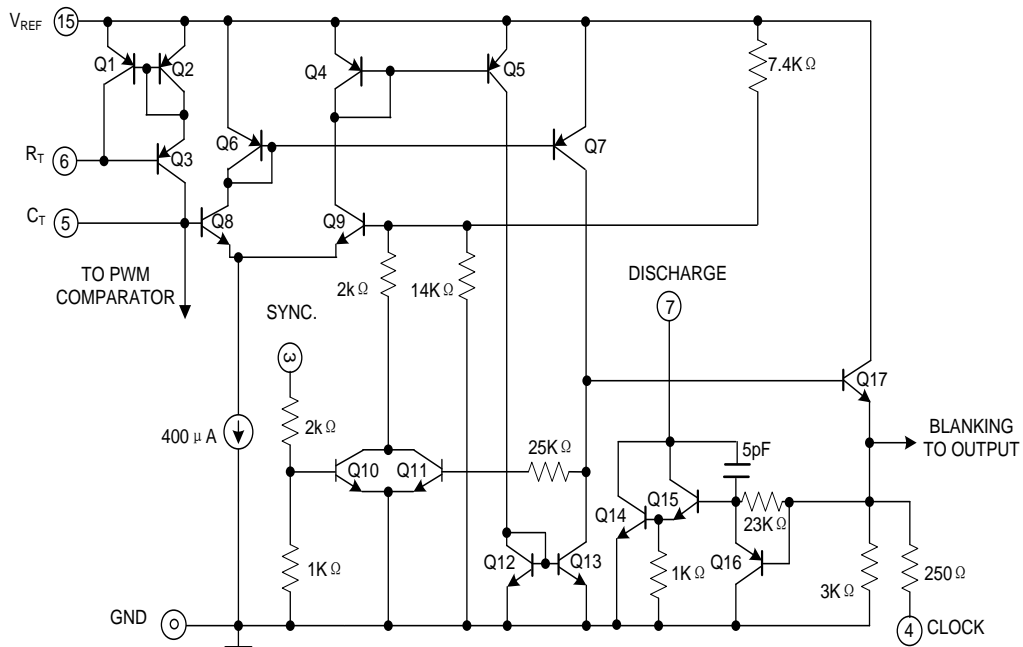

APPLICATION INFORMATION AND CIRCUIT (Cont.)

OUTPUT CIRCUIT (1/2 CIRCUIT SHOWN)

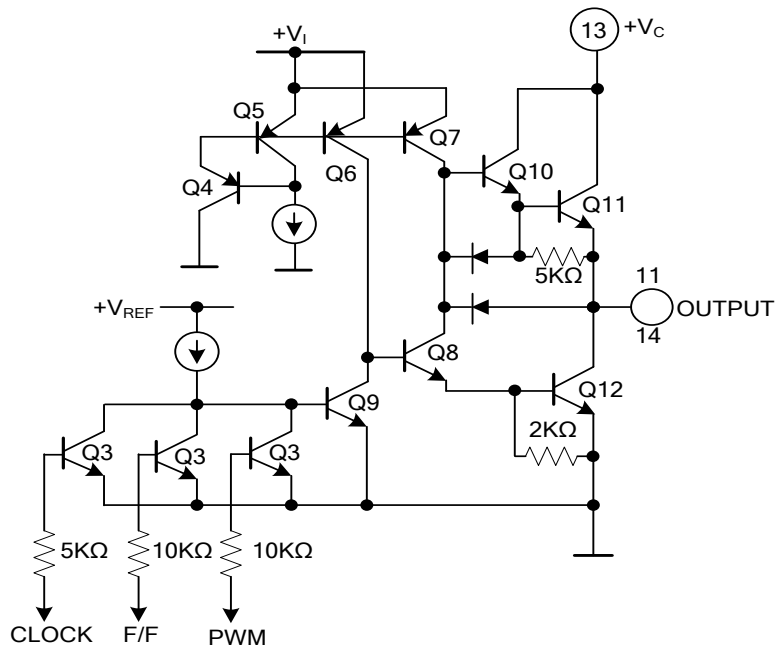

ERROR AMPLIFIER

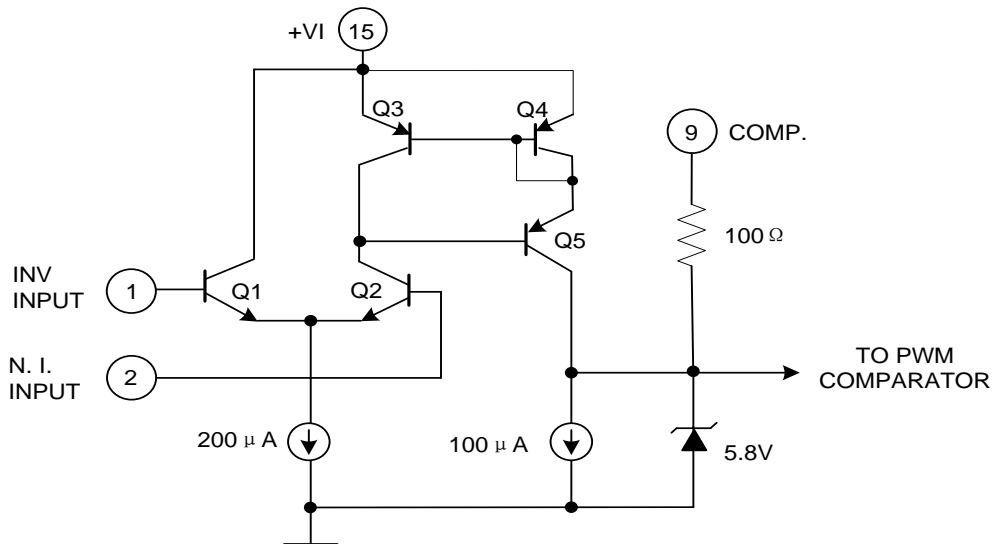

■ TYPICAL CHARACTERISTICS

Oscillator Charge Time vs. R_T and C_T

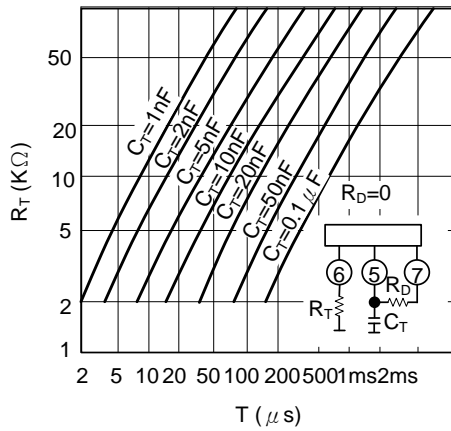

Oscillator DisCharge Time vs. R_D and C_T

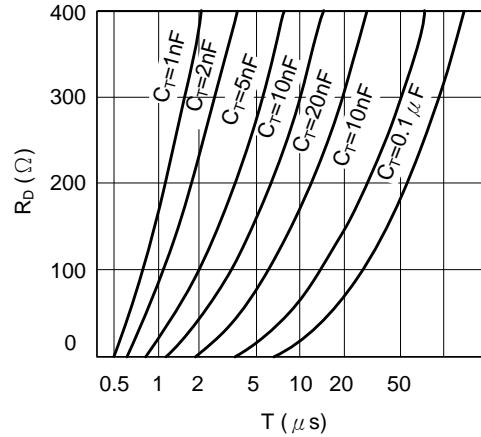

Output Saturation Characteristics

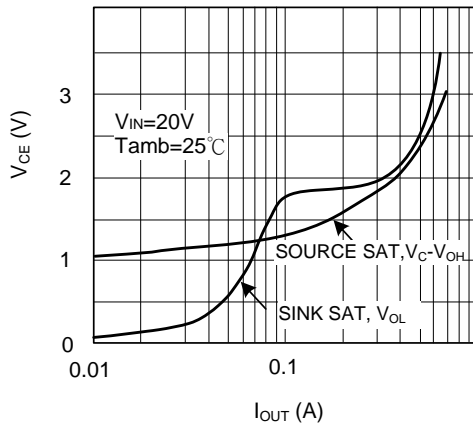

Error Amplifier Voltage Gain and Phase vs. Frequency

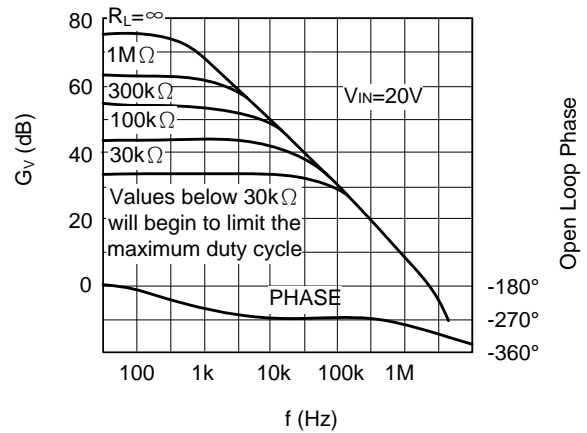

UTC assumes no responsibility for equipment failures that result from using products at values that exceed, even momentarily, rated values (such as maximum ratings, operating condition ranges, or other parameters) listed in products specifications of any and all UTC products described or contained herein. UTC products are not designed for use in life support appliances, devices or systems where malfunction of these products can be reasonably expected to result in personal injury. Reproduction in whole or in part is prohibited without the prior written consent of the copyright owner. UTC reserves the right to make changes to information published in this document, including without limitation specifications and product descriptions, at any time and without notice. This document supersedes and replaces all information supplied prior to the publication hereof.

X-ON Electronics

Largest Supplier of Electrical and Electronic Components

Click to view similar products for [Linear Voltage Regulators](#) category:

Click to view products by [Unisonic](#) manufacturer:

Other Similar products are found below :

[LV5684PVD-XH](#) [MCDTSA6-2R](#) [L7815ACV-DG](#) [LV56801P-E](#) [UA7805CKC](#) [714954EB](#) [ZMR500QFTA](#) [BA033LBSG2-TR](#)
[NCV78M05ABDTRKG](#) [LV5680P-E](#) [L79M05T-E](#) [L78LR05D-MA-E](#) [NCV317MBTG](#) [NTE7227](#) [MP2018GZD-33-P](#) [MP2018GZD-5-P](#)
[LV5680NPVC-XH](#) [ZTS6538SE](#) [UA78L09CLP](#) [UA78L09CLPR](#) [CAT6221-PPTD-GT3](#) [MC78M09CDTRK](#) [NCV51190MNTAG](#)
[BL1118CS8TR1833](#) [BL8077CKETR33](#) [BL9153-33CC3TR](#) [BL9161G-28BADRN](#) [BRCO7530MMC](#) [CJ7815B-TFN-ARG](#) [LM317C](#)
[GM7333K](#) [GM7350K](#) [XC6206P332MR](#) [HT7533](#) [LM7912S/TR](#) [LT1764S/TR](#) [LM7805T](#) [LM338T](#) [LM1117IMP-3.3/TR](#) [HT1117AM-3.3](#)
[HT7550S](#) [AMS1117-3.3](#) [HT7150S](#) [78L12](#) [HT7550](#) [HT7533-1](#) [HXY6206I-2.5](#) [HT7133](#) [HT7533S](#) [662K](#)