



## U74AHC1G04

CMOS IC

### SINGLE INVERTER GATE

#### DESCRIPTION

The **U74AHC1G04** is a inverter gate, it provides the Function  $Y = \bar{A}$ .

#### FEATURES

- \* Operation Voltage Range: 2V ~ 5.5V
- \* Low power consumption,  $I_{CC} = 1\mu A$  (Max) at 5.5V
- \*  $\pm 8mA$  output driver at 5V

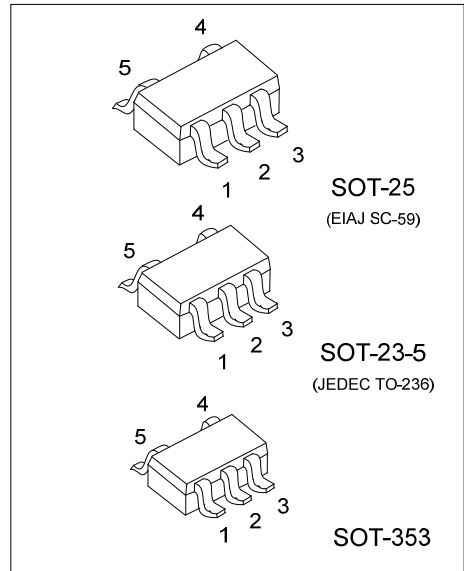

#### ORDERING INFORMATION

Ordering Number		Package	Packing
Lead Free	Halogen Free		
U74AHC1G04L-AE5-R	U74AHC1G04G-AE5-R	SOT-23-5	Tape Reel
U74AHC1G04L-AF5-R	U74AHC1G04G-AF5-R	SOT-25	Tape Reel
U74AHC1G04L-AL5-R	U74AHC1G04G-AL5-R	SOT-353	Tape Reel

<p>U74AHC1G04G-AE5-R</p> <p>(1) Packing Type (2) Package Type (3) Green Package</p>	<p>(1) R: Tape Reel (2) AE5: SOT-23-5, AF5: SOT-25, AL5: SOT-353 (3) G: Halogen Free and Lead Free, L: Lead Free</p>
---	--

#### MARKING

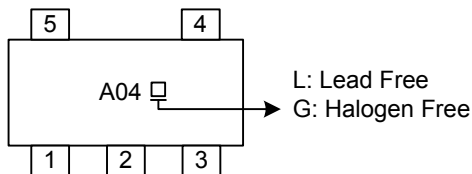

■ PIN CONFIGURATION

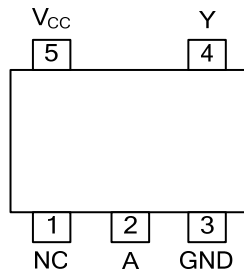

■ FUNCTION TABLE

INPUT(A)	OUTPUT(Y)
H	L
L	H

Note: H: high voltage level; L: low voltage level.

■ LOGIC DIAGRAM

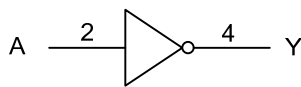

Logic symbol



IEC logic symbol

### ■ ABSOLUTE MAXIMUM RATING

PARAMETER	SYMBOL	RATINGS	UNIT
Supply Voltage	$V_{CC}$	-0.5 ~ 7	V
Input Voltage	$V_{IN}$	-0.5 ~ 7	V
Output Voltage	$V_{OUT}$	-0.5 ~ $V_{CC} + 0.5$	V
$V_{CC}$ or GND Current	$I_{CC}$	±50	mA
Output Current	$I_{OUT}$	±25	mA
Input Clamp Current	$I_{IK}$	-20	mA
Output Clamp Current	$I_{OK}$	±20	mA
Storage Temperature	$T_{STG}$	-65 ~ +150	°C

Notes: 1. Absolute maximum ratings are those values beyond which the device could be permanently damaged.

Absolute maximum ratings are stress ratings only and functional device operation is not implied.

2. The input and output voltage ratings may be exceeded if the input and output current ratings are observed.

### ■ THERMAL DATA

PARAMETER	SYMBOL	RATINGS	UNIT
Junction to Ambient	SOT-23-5	280	°C/W
	SOT-25	230	
	SOT-353	350	

### ■ RECOMMENDED OPERATING CONDITIONS

PARAMETER	SYMBOL	CONDITIONS	MIN	TYP	MAX	UNIT
Supply Voltage	$V_{CC}$		2		5.5	V
Input Voltage	$V_{IN}$		0		5.5	V
Output Voltage	$V_{OUT}$		0		$V_{CC}$	V
Input Transition Rise or Fall Rate	$\Delta t/\Delta v$	$V_{CC}=5.0+0.5V$			20	ns/V
Operating Temperature	$T_A$		-40		125	°C

### ■ ELECTRICAL CHARACTERISTICS

PARAMETER	SYMBOL	TEST CONDITIONS	MIN	TYP	MAX	UNIT
Supply Voltage	$V_{CC}$		2		5.5	V
Input Voltage	$V_{IN}$		0		5.5	V
Output Voltage	$V_{OUT}$		0		$V_{CC}$	V
High-Level Input Voltage	$V_{IH}$	$V_{CC}=2.0V$	1.5			V
		$V_{CC}=3.0V$	2.1			
		$V_{CC}=5.5V$	3.85			
Low-Level Input Voltage	$V_{IL}$	$V_{CC}=2.0V$			0.5	V
		$V_{CC}=3.0V$			0.9	
		$V_{CC}=5.5V$			1.65	
High-Level Output Voltage	$V_{OH}$	$V_{CC}=2.0V$	1.9	2.0	V	
		$V_{CC}=3.0V$				2.9
		$V_{CC}=4.5V$	4.4	4.5		
		$V_{CC}=3.0V, I_{OH}=-4mA$	2.58			
		$V_{CC}=4.5V, I_{OH}=-8mA$	3.94			
Low-Level Output Voltage	$V_{OL}$	$V_{CC}=2.0V$	I <sub>OL</sub> =-50μA		0.1	V
		$V_{CC}=3.0V$			0.1	
		$V_{CC}=4.5V$			0.1	
		$V_{CC}=3.0V, I_{OL}=4mA$		0.36		
		$V_{CC}=4.5V, I_{OL}=8mA$		0.36		
Input Leakage Current	$I_{I(LEAK)}$	$V_{CC}=0V\sim 5.5V,$ $V_{IN}=5.5V$ or GND			±0.1	μA
Quiescent Supply Current	$I_Q$	$V_{CC}=5.5V, V_{IN}=V_{CC}$ or GND, $I_{OUT}=0A$			1	μA
Input Capacitance	$C_I$	$V_{CC}=5.0V, V_{IN}=V_{CC}$ or GND		2	10	pF

### ■ DYNAMIC CHARACTERISTICS

PARAMETER	SYMBOL	TEST CONDITIONS	MIN	TYP	MAX	UNIT	
Propagation Delay Time Input(A) to Output(Y)	t <sub>PLH</sub>	V <sub>CC</sub> =3.3V±0.3V		5	7.1	ns	
		V <sub>CC</sub> =5V±0.5V		3.8	5.5	ns	
	t <sub>PHL</sub>	V <sub>CC</sub> =3.3V±0.3V		C <sub>L</sub> =15pF	5	7.1	ns
		V <sub>CC</sub> =5V±0.5V			3.8	5.5	ns
	t <sub>PLH</sub>	V <sub>CC</sub> =3.3V±0.3V		C <sub>L</sub> =50pF	7.5	10.6	ns
		V <sub>CC</sub> =5V±0.5V			5.3	7.5	ns
	t <sub>PHL</sub>	V <sub>CC</sub> =3.3V±0.3V			7.5	10.6	ns
		V <sub>CC</sub> =5V±0.5V			5.3	7.5	ns

### ■ OPERATING CHARACTERISTICS (T<sub>A</sub>=25°C, unless otherwise specified)

PARAMETER	SYMBOL	TEST CONDITIONS	MIN	TYP	MAX	UNIT
Power Dissipation Capacitance	C <sub>PD</sub>	V <sub>CC</sub> =5V, f=1MHz, No load		12		pF

■ TEST CIRCUIT AND WAVEFORMS

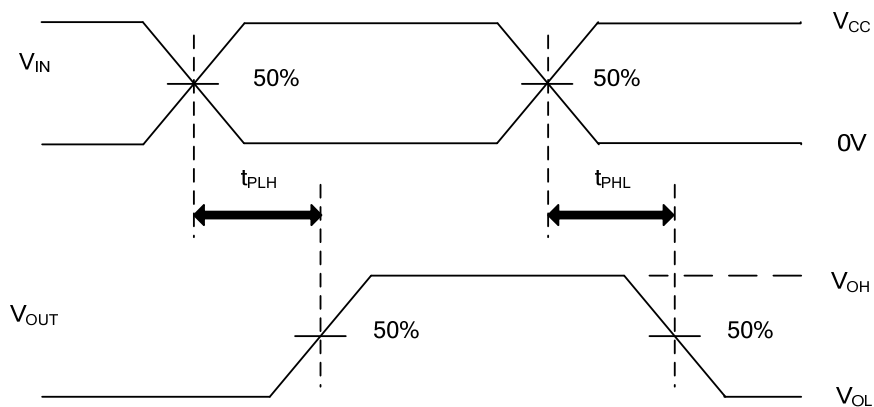
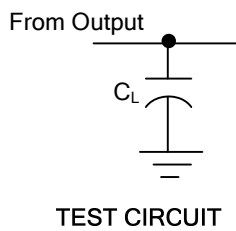

PROPAGATION DELAY TIMES

- Notes: 1.  $C_L$  includes probe and jig capacitance.  
 2.  $P_{RR} \leq 1\text{MHz}$ ,  $Z_O = 50\Omega$ ,  $t_R \leq 3\text{ns}$ ,  $t_F \leq 3\text{ns}$ .

UTC assumes no responsibility for equipment failures that result from using products at values that exceed, even momentarily, rated values (such as maximum ratings, operating condition ranges, or other parameters) listed in products specifications of any and all UTC products described or contained herein. UTC products are not designed for use in life support appliances, devices or systems where malfunction of these products can be reasonably expected to result in personal injury. Reproduction in whole or in part is prohibited without the prior written consent of the copyright owner. UTC reserves the right to make changes to information published in this document, including without limitation specifications and product descriptions, at any time and without notice. This document supersedes and replaces all information supplied prior to the publication hereof.

## X-ON Electronics

Largest Supplier of Electrical and Electronic Components

*Click to view similar products for [Buffers & Line Drivers](#) category:*

*Click to view products by [Unisonic](#) manufacturer:*

Other Similar products are found below :

[5962-9217601MSA](#) [634810D](#) [875140G](#) [HEF4022BP](#) [HEF4043BP](#) [NL17SG125DFT2G](#) [NL17SZ126P5T5G](#) [NLU1GT126CMUTCG](#)  
[NLU3G16AMX1TCG](#) [NLV27WZ125USG](#) [MC74HCT365ADTR2G](#) [BCM6306KMLG](#) [54FCT240CTDB](#) [Le87401NQC](#) [Le87402MQC](#)  
[028192B](#) [042140C](#) [051117G](#) [070519XB](#) [065312DB](#) [091056E](#) [098456D](#) [NL17SG07DFT2G](#) [NL17SG17DFT2G](#) [NL17SG34DFT2G](#)  
[NL17SZ07P5T5G](#) [NL17SZ125P5T5G](#) [NLU1GT126AMUTCG](#) [NLV27WZ16DFT2G](#) [5962-8982101PA](#) [5962-9052201PA](#) [74LVC07ADR2G](#)  
[MC74VHC1G125DFT1G](#) [NL17SH17P5T5G](#) [NL17SZ125CMUTCG](#) [NLV17SZ07DFT2G](#) [NLV37WZ17USG](#) [NLVHCT244ADTR2G](#)  
[NC7WZ17FHX](#) [74HCT126T14-13](#) [NL17SH125P5T5G](#) [NLV14049UBDTR2G](#) [NLV37WZ07USG](#) [74VHC541FT\(BE\)](#) [RHFAC244K1](#)  
[74LVC1G17FW4-7](#) [74LVC1G126FZ4-7](#) [BCM6302KMLG](#) [74LVC1G07FZ4-7](#) [74LVC1G125FW4-7](#)