



## U74LVC245

CMOS IC

### OCTAL BUS TRANSCEIVER WITH 3-STATE OUTPUTS

#### DESCRIPTION

The **U74LVC245** is designed for the communication between data buses asynchronously. While the direction-control(DIR) is high, data transmits from the A bus to the B bus. Data transmits from the B bus to the A bus if DIR is low. The output-enable( $\overline{OE}$ ) will isolate the device from the buses when high voltage is applied on it.

#### FEATURES

- \* Operate From 1.65V to 3.6V
- \* Input Accept Voltages to 5.5V
- \* Partial-Power-Down Mode Operation

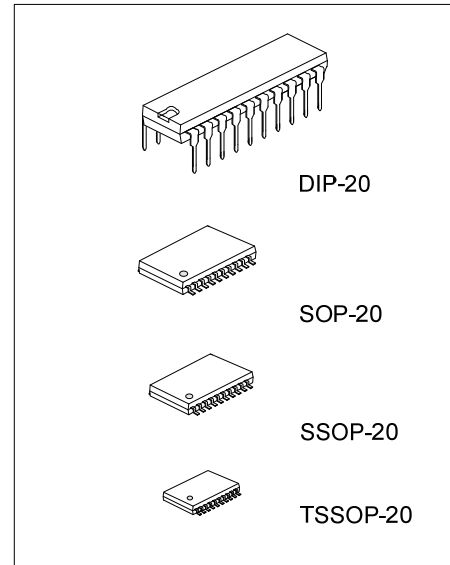

#### ORDERING INFORMATION

Ordering Number		Package	Packing
Lead Free	Halogen Free		
U74LVC245L-D20-T	U74LVC245G-D20-T	DIP-20	Tube
U74LVC245L-S20-R	U74LVC245G-S20-R	SOP-20	Tape Reel
U74LVC245L-R20-R	U74LVC245G-R20-R	SSOP-20	Tape Reel
U74LVC245L-P20-R	U74LVC245G-P20-R	TSSOP-20	Tape Reel

<p>U74LVC245G-D20-T</p> <p>(1) Packing Type (2) Package Type (3) Green Package</p>	<p>(1) T: Tube, R: Tape Reel (2) D20: DIP-20, S20: SOP-20, R20: SSOP-20 P20: TSSOP-20 (3) G: Halogen Free and Lead Free, L: Lead Free</p>
--	---

#### MARKING

DIP-20	SOP-20 / SSOP-20 / TSSOP-20
<p>20 19 18 17 16 15 14 13 12 11 → Date Code UTC □□□□ L: Lead Free U74LVC245 □ → G: Halogen Free □□ → Lot Code 1 2 3 4 5 6 7 8 9 10</p>	<p>20 19 18 17 16 15 14 13 12 11 → Date Code UTC □□□□ L: Lead Free U74LVC245 □ → G: Halogen Free □□ → Lot Code 1 2 3 4 5 6 7 8 9 10</p>

■ PIN CONFIGURATION

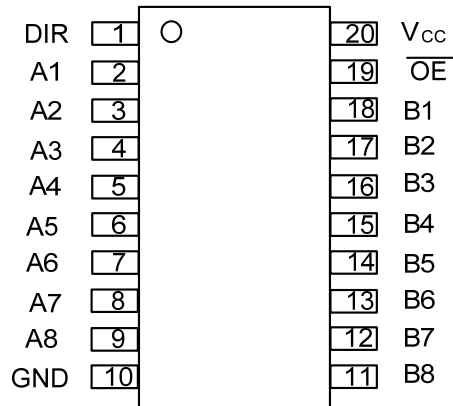

■ FUNCTION TABLE (each gate)

INPUT		FUNCTION
$\overline{OE}$	DIR	
H	x	Isolation
L	H	Transmit data from A bus to B bus
L	L	Transmit data from B bus to A bus

■ LOGIC DIAGRAM (positive logic)

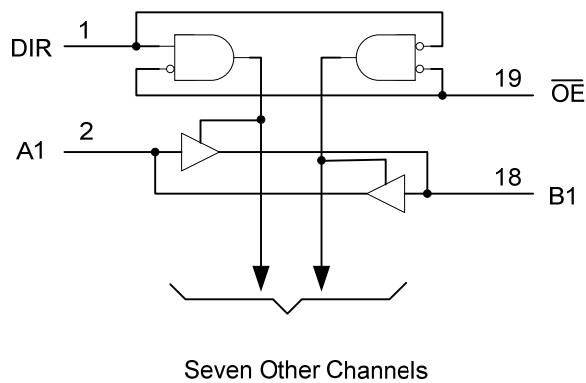

## ■ ABSOLUTE MAXIMUM RATINGS

PARAMETER	SYMBOL	RATINGS	UNIT
Supply Voltage	$V_{CC}$	-0.5 ~ 6.5	V
Input Voltage	$V_{IN}$	-0.5 ~ 6.5	V
Voltage Applied To Output In High-Impedance or Power-off State	$V_{OUT}$	-0.5 ~ 6.5	V
Voltage Applied to Output In High or Low State		-0.5 ~ $V_{CC}+0.5$	V
Input Clamp Current	$I_{IK}$	-50	mA
Output Clamp Current	$I_{OK}$	-50	mA
Output Current	$I_{OUT}$	±50	mA
$V_{CC}$ or GND Current	$I_{CC}$	±100	mA
Operating Temperature	$T_{OPR}$	-40 ~ +125	°C
Storage Temperature	$T_{STG}$	-65 ~ +150	°C

Note: 1. The input and output voltage ratings may be exceeded if the input and output current ratings are observed.

2. Absolute maximum ratings are those values beyond which the device could be permanently damaged.

Absolute maximum ratings are stress ratings only and functional device operation is not implied.

## ■ THERMAL DATA

PARAMETER	SYMBOL	RATINGS	UNIT
Junction to Ambient	$\theta_{JA}$	60	°C/W
		85	°C/W
		106	°C/W
		110	°C/W

## ■ RECOMMENDED OPERATING CONDITIONS

PARAMETER	SYMBOL	TEST CONDITIONS	MIN	TYP	MAX	UNIT
Supply Voltage	$V_{CC}$	Operating	1.65		3.6	V
		Data retention only	1.5			V
Input Voltage High-Level	$V_{IH}$	$V_{CC} = 1.65 \text{ V to } 1.95 \text{ V}$	0.65			V
		$V_{CC} = 2.3 \text{ V to } 2.7 \text{ V}$	1.7			V
		$V_{CC} = 2.7 \text{ V to } 3.6 \text{ V}$	2			V
Input Voltage Low-Level	$V_{IL}$	$V_{CC} = 1.65 \text{ V to } 1.95 \text{ V}$			0.35	V
		$V_{CC} = 2.3 \text{ V to } 2.7 \text{ V}$			0.7	V
		$V_{CC} = 2.7 \text{ V to } 3.6 \text{ V}$			0.8	V
Input Voltage	$V_{IN}$		0		5.5	V
Output Voltage	$V_{OUT}$		0		$V_{CC}$	V

### ■ ELECTRICAL CHARACTERISTICS

PARAMETER	SYMBOL	TEST CONDITIONS	MIN	TYP	MAX	UNIT
Output Voltage High-Level	$V_{OH}$	$V_{CC}=1.65V$ to $3.6V$ , $I_{OH} = -100\mu A$	$V_{CC}-0.2$			V
		$V_{CC}=1.65V$ , $I_{OH} = -4mA$	1.29			V
		$V_{CC}=2.3V$ , $I_{OH} = -8mA$	1.9			V
		$V_{CC}=2.7V$ , $I_{OH} = -12mA$	2.2			V
		$V_{CC}=3V$ , $I_{OH} = -12mA$	2.4			V
		$V_{CC}=3V$ , $I_{OH} = -24mA$	2.3			V
Output Voltage Low-Level	$V_{OL}$	$V_{CC}=1.65V$ to $3.6V$ , $I_{OL} = 100\mu A$			0.1	V
		$V_{CC}=1.65V$ , $I_{OL} = 4mA$			0.24	V
		$V_{CC}=2.3V$ , $I_{OL} = 8mA$			0.3	V
		$V_{CC}=2.7V$ , $I_{OL} = 12mA$			0.4	V
		$V_{CC}=3V$ , $I_{OL} = 24mA$			0.55	V
Input Leakage Current	$I_{I(LEAK)}$	$V_{CC}=3.6V$ , $V_{IN} = 5.5V$ or GND			$\pm 1$	$\mu A$
Power OFF Leakage Current	$I_{OFF}$	$V_{CC} = 0V$ , $V_{IN}$ or $V_{OUT} = 5.5V$			$\pm 1$	$\mu A$
Input Leakage Current (For I/O Ports)	$I_{OZ}$	$V_{CC}=3.6V$ , $V_{OUT} = 0 \sim 5.5V$			$\pm 1$	$\mu A$
Quiescent Supply Current	$I_Q$	$V_{CC}=3.6V$ , $V_{IN} = V_{CC}$ or GND, $I_{OUT} = 0$			1	$\mu A$
		$V_{CC}=3.6V$ , $3.6V \leq V_{IN} \leq 5.5V$ , $I_{OUT} = 0$			1	
Additional Quiescent Supply Current	$\Delta I_Q$	$V_{CC}=2.7V$ to $3.6V$ , One input at $V_{CC} - 0.6V$ , Other inputs at $V_{CC}$ or GND			500	$\mu A$
Input Capacitance	$C_{IN}$	$V_{CC}=3.3V$ , $V_{IN} = V_{CC}$ or GND		4		pF

### ■ SWITCHING CHARACTERISTICS

PARAMETER	SYMBOL	TEST CONDITIONS	MIN	TYP	MAX	UNIT
Propagation Delay From A to B or B to A	$t_{PLH}/t_{PHL}$	$V_{CC}=1.8V \pm 0.15V$	1	6	12.2	ns
		$V_{CC}=2.5V \pm 0.2V$	1	3.9	7.8	ns
		$V_{CC}=2.7V$	1	4.2	7.1	ns
		$V_{CC}=3.3V \pm 0.3V$	1.5	3.8	6.1	ns
Propagation Delay From $\overline{OE}$ to A or B	$t_{PZL}/t_{PZH}$	$V_{CC}=1.8V \pm 0.15V$	1	7	14.8	ns
		$V_{CC}=2.5V \pm 0.2V$	1	4.5	10	ns
		$V_{CC}=2.7V$	1	5.4	9.3	ns
		$V_{CC}=3.3V \pm 0.3V$	1.5	4.4	8.3	ns
Propagation Delay From $\overline{OE}$ A to A or B	$t_{PLZ}/t_{PHZ}$	$V_{CC}=1.8V \pm 0.15V$	1	7.8	16.5	ns
		$V_{CC}=2.5V \pm 0.2V$	1	4	9	ns
		$V_{CC}=2.7V$	1	4.4	8.3	ns
		$V_{CC}=3.3V \pm 0.3V$	1.7	4.1	7.3	ns

### ■ OPERATING CHARACTERISTICS

PARAMETER	SYMBOL	TEST CONDITIONS	MIN	TYP	MAX	UNIT
Power Dissipation Capacitance	$C_{PD}$	$\overline{OE} = 0$ , $f=10MHz$ , $V_{CC}=1.8V$		42		pF
		$\overline{OE} = 0$ , $f=10MHz$ , $V_{CC}=2.5V$		43		pF
		$\overline{OE} = 0$ , $f=10MHz$ , $V_{CC}=3.3V$		45		pF
		$\overline{OE} = 1$ , $f=10MHz$ , $V_{CC}=1.8V$		1		pF
		$\overline{OE} = 1$ , $f=10MHz$ , $V_{CC}=2.5V$		1		pF
		$\overline{OE} = 1$ , $f=10MHz$ , $V_{CC}=3.3V$		2		pF

## TEST CIRCUIT AND WAVEFORMS

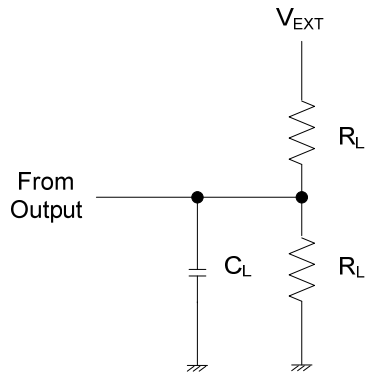

V <sub>CC</sub>	V <sub>IN</sub>	t <sub>R</sub> /t <sub>F</sub>	V <sub>M</sub>	V $\Delta$	C <sub>L</sub>	R <sub>L</sub>	V <sub>EXT</sub>		
							t <sub>PLH</sub> /t <sub>PHL</sub>	t <sub>PZH</sub> /t <sub>PHZ</sub>	t <sub>PZL</sub> /t <sub>PLZ</sub>
1.8V $\pm$ 0.15V	V <sub>CC</sub>	$\leq$ 2ns	V <sub>CC</sub> /2	0.15V	30 pF	1 k $\Omega$	OPEN	GND	2*V <sub>CC</sub>
2.5V $\pm$ 0.2V	V <sub>CC</sub>	$\leq$ 2ns	V <sub>CC</sub> /2	0.15V	30 pF	500 $\Omega$	OPEN	GND	2*V <sub>CC</sub>
2.7 V	2.7 V	$\leq$ 2.5ns	1.5V	0.3V	50 pF	500 $\Omega$	OPEN	GND	6 V
3.3V $\pm$ 0.3V	2.7 V	$\leq$ 2.5ns	1.5V	0.3V	50 pF	500 $\Omega$	OPEN	GND	6 V

Fig. 1 Load circuitry

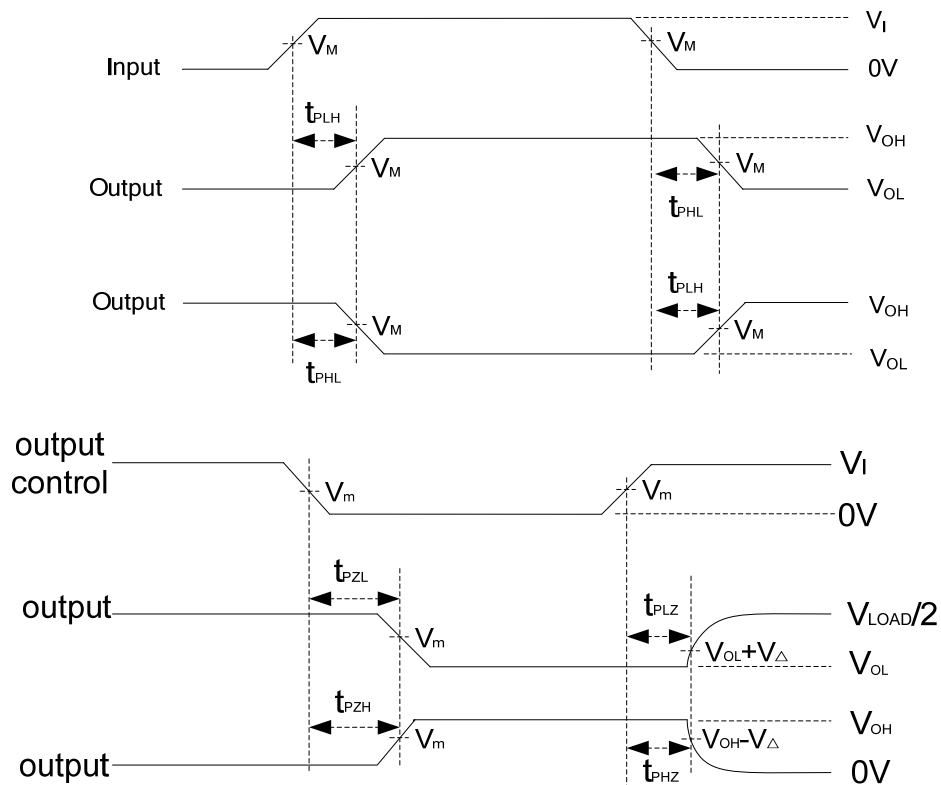

Fig. 2 Propagation delay waves

UTC assumes no responsibility for equipment failures that result from using products at values that exceed, even momentarily, rated values (such as maximum ratings, operating condition ranges, or other parameters) listed in products specifications of any and all UTC products described or contained herein. UTC products are not designed for use in life support appliances, devices or systems where malfunction of these products can be reasonably expected to result in personal injury. Reproduction in whole or in part is prohibited without the prior written consent of the copyright owner. UTC reserves the right to make changes to information published in this document, including without limitation specifications and product descriptions, at any time and without notice. This document supersedes and replaces all information supplied prior to the publication hereof.

## X-ON Electronics

Largest Supplier of Electrical and Electronic Components

*Click to view similar products for [Logic Gates](#) category:*

*Click to view products by [Unisonic](#) manufacturer:*

Other Similar products are found below :

[NL17SG32DFT2G](#) [CD4068BE](#) [NL17SG86DFT2G](#) [NLX1G11AMUTCG](#) [NLX1G97MUTCG](#) [74LS38](#) [74LVC1G08Z-7](#) [CD4025BE](#)  
[NLV17SZ00DFT2G](#) [NLV17SZ126DFT2G](#) [NLV27WZ17DFT2G](#) [NLV74HC02ADR2G](#) [74HC32S14-13](#) [74LS133](#) [74LVC1G32Z-7](#)  
[74LVC1G86Z-7](#) [NLV74HC14ADR2G](#) [NLV74HC20ADR2G](#) [NLVVHC1G09DFT1G](#) [NLX2G86MUTCG](#) [74LVC2G32RA3-7](#)  
[74LVC2G00HD4-7](#) [NL17SG02P5T5G](#) [74LVC2G86HK3-7](#) [NLVVHC1G14DFT2G](#) [NLX1G99DMUTWG](#) [NLVVHC1G00DFT2G](#)  
[NLV7SZ57DFT2G](#) [NLV74VHC04DTR2G](#) [NLV27WZ00USG](#) [NLU1G86CMUTCG](#) [NLU1G08CMUTCG](#) [NL17SZ32P5T5G](#)  
[NL17SZ00P5T5G](#) [NL17SH02P5T5G](#) [74AUP2G00RA3-7](#) [NLVVHC1GT00DFT2G](#) [NLV74HC02ADTR2G](#) [NLX1G332CMUTCG](#)  
[NLVHCT132ADTR2G](#) [NL17SG86P5T5G](#) [NL17SZ05P5T5G](#) [NLV74VHC00DTR2G](#) [NLVVHC1G02DFT1G](#) [NLV74HC86ADR2G](#)  
[74LVC2G86RA3-7](#) [NL17SZ38DBVT1G](#) [NLV18SZ00DFT2G](#) [NLVVHC1G07DFT1G](#) [NLVVHC1G02DFT2G](#)