



UM66TXXL

CMOS IC

MELODY INTEGRATED CIRCUIT

DESCRIPTION

The UTC UM66TXXL series are CMOS LSI designed for using in door bell, telephone and toy application. It is an on-chip ROM programmed for musical performance. Produced by CMOS technology, the device results in very low power consumption. Since the UTC UM66TXXL series include oscillation circuits a compact melody module can be constructed with only a few additional components.

FEATURES

- *64-Note Rom memory
- *1.5V ~ 4.5V power supply and low power consumption
- *Dynamic speaker can be driven with external NPN transistor
- *OSC resistor hold mode
- *Power on reset: melody begins from the first note
- *Built in level hold mode

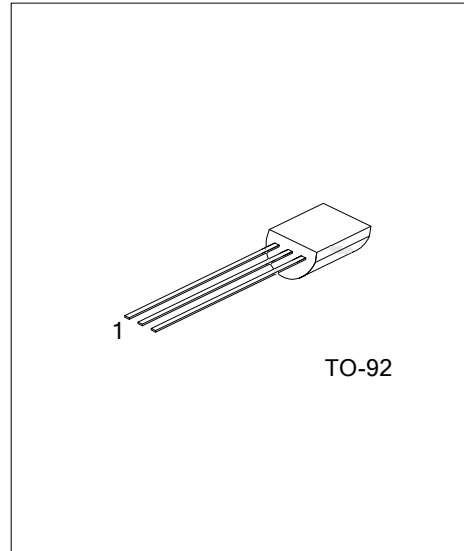

ORDERING INFORMATION

Order Number		Package	Pin Assignment			Packing
Lead Free	Halogen Free		1	2	3	
UM66TxxLK-T92-B	UM66TxxLG-T92-B	TO-92	V _{SS}	V _{DD}	O/P	Tape Box
UM66TxxLK-T92-K	UM66TxxLG-T92-K	TO-92	V _{SS}	V _{DD}	O/P	Bulk

<p>UM66TxxLK-T92-B</p> <p>(1) Packing Type</p> <p>(2) Package Type</p> <p>(3) Green Package</p> <p>(4) Song Series</p>	<p>(1) B: Tape Box, K: Bulk, R: Tape Reel</p> <p>(2) T92: TO-92</p> <p>(3) K: Lead Free, G: Halogen Free and Lead Free</p> <p>(4) xx: refer to SONG SERIES LIST</p>
------------------------------------------------------------------------------------------------------------------------	---------------------------------------------------------------------------------------------------------------------------------------------------------------------

SONG SERIES LIST

P/N	SONG NAME
UTC UM66T05L	Home Sweet Home
UTC UM66T08L	Happy Birthday
UTC UM66T11L	Love Me Tender
UTC UM66T19L	For Alice
UTC UM66T32L	COO COO waltz

MARKING

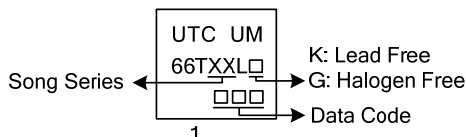

■ ABSOLUTE MAXIMUM RATINGS (Operating temperature range applies unless otherwise specified.)

PARAMETER	SYMBOL	RATINGS	UNIT
DC Supply Voltage	V_{DD}	1.5 ~ 4.5	V
Operating Temperature	T_{OPR}	-10 ~ +60	°C
Storage Temperature	T_{STG}	-55 ~ +125	°C

Notes: Stress above those listed under absolute maximum ratings may cause permanent damage to the device.

These are stress ratings only. Functional operations of this device at these or any other conditions above those indicated in the operational section of this specification is not implied and exposure to absolute maximum ratings conditions for extended periods may affect device reliably.

■ ELECTRICAL CHARACTERISTICS ($V_{SS}=0V$, $F_{OSC}=65536Hz$, $T_J=25^{\circ}C$, unless otherwise specified)

PARAMETER	SYMBOL	TEST CONDITIONS	MIN	TYP	MAX	UNIT
Operating Voltage	V_{DD}		1.5		4.5	V
Operating Current	I_{DD}	$V_{DD}=1.5V$, O/P open			60	μA
O/P Drive Current	$I_{O(DRIVE)}$	$V_{DD}=1.5V$, O/P=0.8V	400	600		μA
O/P Sink Current	$I_{O(SINK)}$	$V_{DD}=1.5V$, O/P=0.5V open	350	450		μA
Frequency Deviation Deviation Per Lot	$\Delta F/F$	$V_{DD}=1.5V$			-12	%
Frequency Stability	$\Delta F/F$	$\frac{F_{osc}(1.6V) - F_{osc}(1.5V)}{F_{osc}(1.5V)}$			10	%

■ FUNCTIONAL DESCRIPTION

OSCILLATOR CIRCUIT

The oscillator frequency is used as a time for tone and beat generators. Its accuracy affects the quality of the music.

TONE GENERATOR

Tone Frequencies are oscillator frequencies-M, where m is any even number from 64 to 256. Within a melody 14C scales can be selected including Pause code and End code. The tone generator is a programmed divider, The Range of Scales is from "C4" to "C6" and range of frequency varies from 258Hz to 23768Hz.

RHYTHM GENERATOR

The rhythm generator is also programmed dividers. It contain 15 available rhythms as follows: 1/4, 1/2, 3/4, 1, 1-1/4, 1-1/2, 1-3/4, 2, 2-1/4, 2-1/2, 2-3/4, 3, 3-1/4, 3-1/2, 3-3/4. Four rhythms can be selected from these.

MELODY ROM

The Mask Rom can memorize 64 notes with 6 bit. 4 bits are used for controlling the scale code and 2 bits are used for controlling the rhythm code.

TEMPO GENERATOR

There are 15 available tempos in the UTC UM66T series. The 15 tempos are: 128, 137, 148, 160, 175, 192, 213, 240, 274, 320, 480, 640, 960, 1920 J/minute.

■ APPLICATION CIRCUITS

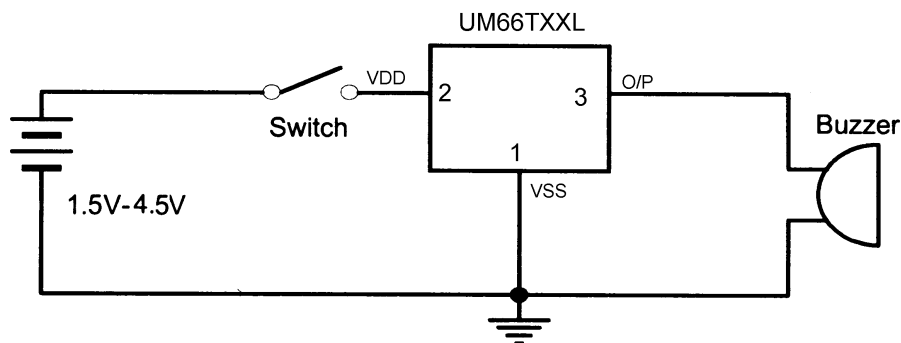

Fig.1

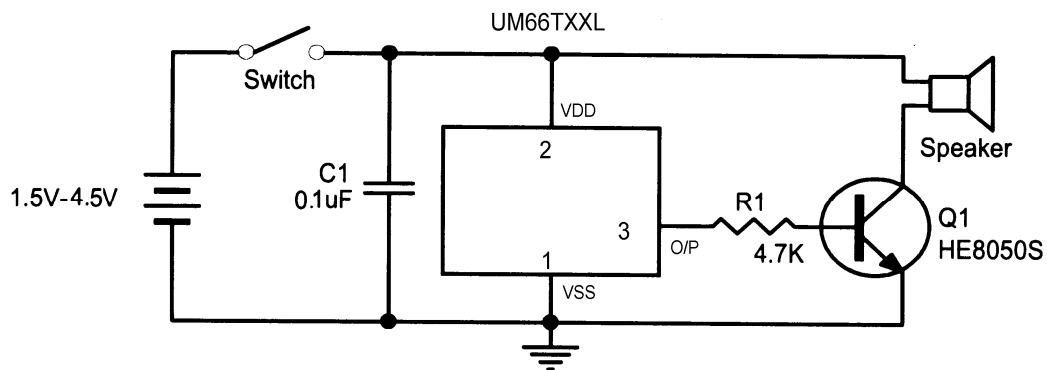

Fig.2

UTC assumes no responsibility for equipment failures that result from using products at values that exceed, even momentarily, rated values (such as maximum ratings, operating condition ranges, or other parameters) listed in products specifications of any and all UTC products described or contained herein. UTC products are not designed for use in life support appliances, devices or systems where malfunction of these products can be reasonably expected to result in personal injury. Reproduction in whole or in part is prohibited without the prior written consent of the copyright owner. The information presented in this document does not form part of any quotation or contract, is believed to be accurate and reliable and may be changed without notice.

X-ON Electronics

Largest Supplier of Electrical and Electronic Components

Click to view similar products for [Audio DSPs](#) category:

Click to view products by [Unisonic](#) manufacturer:

Other Similar products are found below :

[AT85C51SND3B1-RTTUL](#) [BR281W31A101V1G](#) [SA3229-E1-T](#) [IA8201-RDI-01](#) [R3710-CEAA-E1](#) [CS48L10-CNZ](#) [CS48L10-CNZR](#)
[CS47024C-CQZ](#) [CS48L10-CWZR](#) [CS48L11-CNZ](#) [TAS3204PAGR](#) [BD37514FS-E2](#) [NJM2294V-TE1](#) [LC823450TA-2H](#) [LC823450XDTBG](#)
[ZL38052LDG1](#) [ADAU1450WBCPZ-RL](#) [ADAU1701JSTZ-RL](#) [ADAU1701JSTZ](#) [FSEIASLD-32G](#) [CI1103](#) [CS47048C-CQZ](#) [CS48560-DQZ](#)
[CS496102-CQZ](#) [CS181002-CQZ](#) [PT2399](#) [XD567](#) [XD1881](#) [TDA7440D013TR](#) [IA8201CQ](#) [SPK2611HM7H-1-2](#) [ALC662-VD0-GR](#)
[ALC662-GR](#) [CM108B](#) [CM118B](#) [HS-100B](#) [S1V30120F01A100](#) [CMX138AE1](#) [LC786820E-6E03-3H](#) [CMX823E4](#) [LC823455XATBG](#)
[LC89058W-E](#) [CM119BN](#) [CM6533N](#) [CM6530N](#) [XFS3031CNP](#) [BD37033FV-ME2](#) [BM28720MUV-E2](#) [WT588D-20SS](#) [BD3702FV-E2](#)