



UR132

LINEAR INTEGRATED CIRCUIT

200mA LOW DROPOUT LINEAR VOLTAGE REGULATOR

DESCRIPTION

The UTC **UR132** is a 200mA fixed output voltage low dropout linear regulator. Wide range of available output voltage fits most of applications. Built-in output current-limiting most thermal-limiting provide maximal protection against any fault conditions.

FEATURES

- * Guaranteed 200mA output current
- * Input voltage range up to 12V
- * Extremely tight load regulation
- * Fast transient response
- * Current-limiting and thermal-limiting
- * Three-terminal adjustable or fixed voltage.

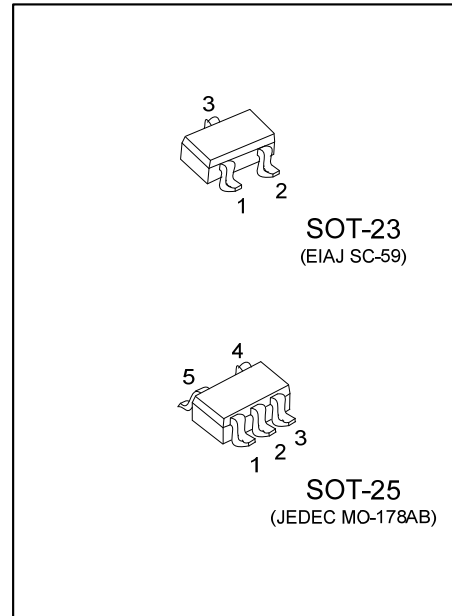

ORDERING INFORMATION

Order Number		Package	Pin Assignment.					Packing
Lead Free	Halogen Free		1	2	3	4	5	
UR132L-xx-AE3-3-R	UR132G-xx-AE3-3-R	SOT-23	G	O	I	-	-	Tape Reel
UR132L-xx-AE3-5-R	UR132G-xx-AE3-5-R	SOT-23	O	G	I	-	-	Tape Reel
UR132L-xx-AF5-C-R	UR132G-xx-AF5-C-R	SOT-25	I	G	N	N	O	Tape Reel

Note: Pin assignment: G:GND O:V_{OUT} I:V_{IN} N: No Connection
xx: output voltage, refer to Marking Information

<p>UR132G-xx-AE3-3-R</p> <p>(1) Packing Type (2) Pin Assignment (3) Package Type (4) Output Voltage Code (5) Green Package</p>	<p>(1) R: Tape Reel (2) refer to Pin Assignment (3) AE3: SOT-23, AF5: SOT-25 (4) xx: refer to Marking Information (5) G: Halogen Free and Lead Free, L: Lead Free</p>
--	---

MARKING INFORMATION

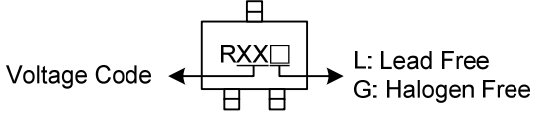
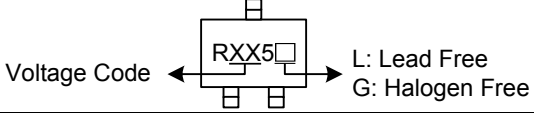
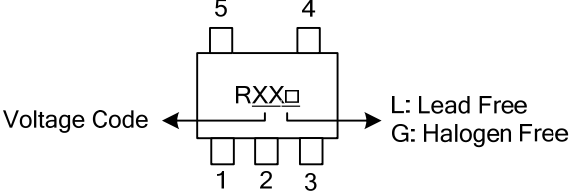
PACKAGE	VOLTAGE CODE	Pin Assignment	MARKING
SOT-23	12: 1.2V 15: 1.5V 18: 1.8V	GOI	
	22: 2.2V 2E: 2.5V 26: 2.6V 27: 2.7V	OGI	
SOT-25	28: 2.8V 30: 3.0V 33: 3.3V 50: 5.0V AD: ADJ	IGNNO	

BLOCK DIAGRAM

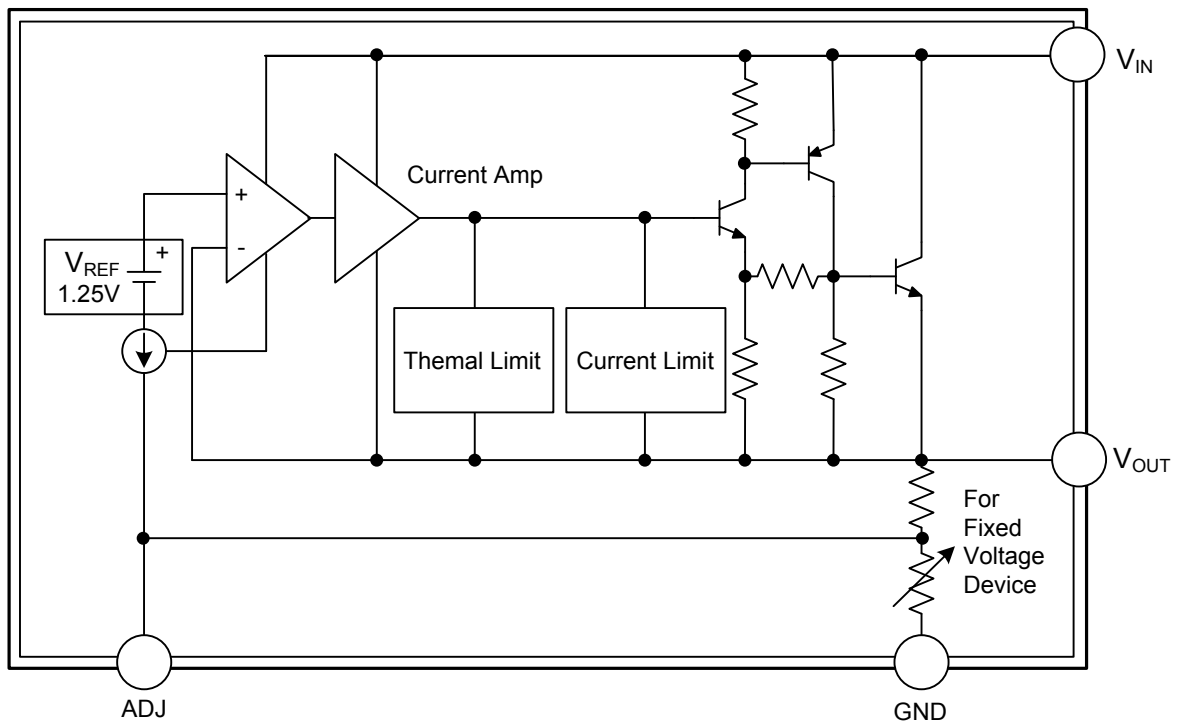

■ ABSOLUTE MAXIMUM RATINGS

PARAMETER	SYMBOL	RATING	UNIT
Input Voltage	V_{IN}	-0.3 ~ 12	V
Power Dissipation	P_D	300	mW
Junction Temperature	T_J	+125	°C
Operation Temperature	T_{OPR}	-40 ~ +85	°C
Storage Temperature	T_{STG}	-40 ~ +150	°C

Note: Absolute maximum ratings are those values beyond which the device could be permanently damaged. Absolute maximum ratings are stress ratings only and functional device operation is not implied.

■ ELECTRICAL CHARACTERISTICS ($T_A=25^\circ\text{C}$, $C_{IN}=1\mu\text{F}$, $C_{OUT}=10\mu\text{F}$, unless otherwise specified)

FOR $V_{OUT}<3.3\text{V}$ ($V_{OUT}\pm 2\%$)

PARAMETER	SYMBOL	TEST CONDITIONS	MIN	TYP	MAX	UNIT
Output Voltage	V_{OUT}	$I_L=2\text{mA}$, $V_{IN}-V_{OUT}=2\text{V}$	$V_{OUT}\times 0.98$	V_{OUT}	$V_{OUT}\times 1.02$	V
Output Voltage Temperature Coefficient	$T_C V_O$			50	150	ppm/°C
Line Regulation	ΔV_{OUT}	$I_L=2\text{mA}$, $V_{IN}-V_{OUT}=2\text{V}\sim V_{IN}=9\text{V}$			0.5	% V_{OUT}
Load Regulation (Note 2)	ΔV_{OUT}	$I_L=2\text{mA}\sim 200\text{mA}$, $V_{IN}-V_{OUT}=2\text{V}$		10	30	mV
Current Limit (Note 3)	I_L	$V_{IN}-V_{OUT}=2\text{V}$, $V_{OUT}=0\text{V}$	300			mA
Dropout Voltage (Note 4,5)	V_D				1.5	V
Standby current	I_{STN-BY}	$I_L=0$, $V_{IN}=9\text{V}$			3.0	mA

FOR ADJ and $V_{OUT}\geq 3.3\text{V}$ ($V_{OUT}\pm 2\%$)

PARAMETER	SYMBOL	TEST CONDITIONS	MIN	TYP	MAX	UNIT
Output Voltage	V_{OUT}	$I_L=2\text{mA}$, $V_{IN}-V_{OUT}=2\text{V}$	$V_{OUT}\times 0.98$	V_{OUT}	$V_{OUT}\times 1.02$	V
ADJUSTABLE ($R_1=120\Omega$, $R_2=200\Omega$, $V_{OUT}=3.3\text{V}$)						
Reference Voltage	V_{REF}	$V_{IN}-V_{OUT}=2\text{V}$, $I_L=2\text{mA}$	1.238	1.250	1.262	V
Output Voltage Temperature Coefficient	$T_C V_O$			50	150	ppm/°C
Line Regulation	ΔV_{OUT}	$I_L=2\text{mA}$, $V_{IN}-V_{OUT}=2\text{V}\sim V_{IN}=12\text{V}$			0.5	% V_{OUT}
Load Regulation (Note 2)	ΔV_{OUT}	$I_L=2\text{mA}\sim 200\text{mA}$, $V_{IN}-V_{OUT}=2\text{V}$		10	30	mV
Current Limit (Note 3)	I_L	$V_{IN}-V_{OUT}=2\text{V}$, $V_{OUT}=0\text{V}$	300			mA
Dropout Voltage (Note 4,5)	V_D				1.3	V
Standby current	I_{STN-BY}	$I_L=0$, $V_{IN}=12\text{V}$			5.0	mA

- Note:
1. Guaranteed by design.
 2. Regulation is measured at constant junction temperature, using pulsed on time.
 3. Current limit is measured at constant junction temperature, using pulsed on time.
 4. Dropout is measured at constant junction temperature, using pulsed on time, and the criterion is V_{OUT} inside target value $\pm 2\%$.
 5. Dropout test is skipped at the condition of $V_{IN}<3\text{V}$.

■ TYPICAL APPLICATION CIRCUIT

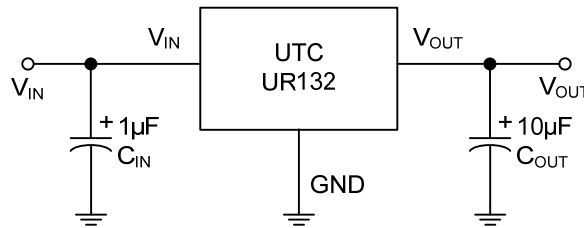

The part may oscillate without the capacitor, a 10µF (or larger) capacitor is recommended between V_{OUT} and GND for stability. Any type of capacitor can be used, but not Aluminum electrolytic when operating below -20°C. The capacitance may be increased without limit. Besides, another 1µF capacitor (or larger) should be placed between V_{IN} to GND.

■ UR132 ADJUSTABLE

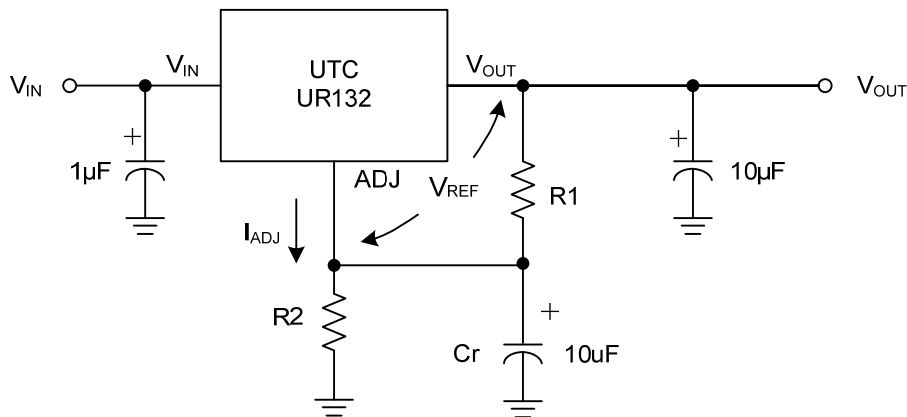

Cr:10µF to improve ripple rejection

$$V_{OUT} = V_{REF}(1 + R2/R1) + I_{ADJ} \times R2$$

UTC assumes no responsibility for equipment failures that result from using products at values that exceed, even momentarily, rated values (such as maximum ratings, operating condition ranges, or other parameters) listed in products specifications of any and all UTC products described or contained herein. UTC products are not designed for use in life support appliances, devices or systems where malfunction of these products can be reasonably expected to result in personal injury. Reproduction in whole or in part is prohibited without the prior written consent of the copyright owner. UTC reserves the right to make changes to information published in this document, including without limitation specifications and product descriptions, at any time and without notice. This document supersedes and replaces all information supplied prior to the publication hereof.

X-ON Electronics

Largest Supplier of Electrical and Electronic Components

Click to view similar products for [Linear Voltage Regulators](#) category:

Click to view products by [Unisonic](#) manufacturer:

Other Similar products are found below :

[LV56831P-E](#) [LV5684PVD-XH](#) [MCDTSA6-2R](#) [L4953G](#) [L7815ACV-DG](#) [PQ3DZ53U](#) [LV56801P-E](#) [TCR3DF13,LM\(CT](#)
[TCR3DF39,LM\(CT](#) [TLE42794G](#) [L78L05CZ/1SX](#) [L78LR05DL-MA-E](#) [L78MR05-E](#) [033150D](#) [033151B](#) [090756R](#) [636416C](#)
[NCV78M15BDTG](#) [702482B](#) [714954EB](#) [TLE42794GM](#) [TLE42994GM](#) [ZMR500QFTA](#) [BA033LBSG2-TR](#) [NCV78M05ABDTRKG](#)
[NCV78M08BDTRKG](#) [NCP7808TG](#) [NCV571SN12T1G](#) [LV5680P-E](#) [CAJ24C256YI-GT3](#) [L78M15CV-DG](#) [L9474N](#)
[TLS202B1MBV33HTSA1](#) [L79M05T-E](#) [NCP571SN09T1G](#) [MAX15006AASA/V+](#) [MIC5283-5.0YML-T5](#) [L4969URTR-E](#) [L78LR05D-MA-E](#)
[NCV7808BDTRKG](#) [L9466N](#) [NCP7805ETG](#) [SC7812CTG](#) [NCV7809BTG](#) [NCV571SN09T1G](#) [NCV317MBTG](#) [MC78M15CDTT5G](#)
[MC78M12CDTT5G](#) [L9468N](#) [LT1054IS8#TRPBF](#)