



UTT50P06

Power MOSFET

-50A, -60V P-CHANNEL (D-S) POWER MOSFET

DESCRIPTION

The UTC **UTT50P06** is a P-channel power MOSFET using UTC's advanced technology to provide the customers with high switching speed and a minimum on-state resistance, and it can also withstand high energy in the avalanche.

This UTC **UTT50P06** is suitable for load switch, etc.

FEATURES

- * $R_{DS(ON)} \leq 15 \text{ m}\Omega @ V_{GS}=-10\text{V}, I_D=-17\text{A}$
- $R_{DS(ON)} \leq 20 \text{ m}\Omega @ V_{GS}=-4.5\text{V}, I_D=-14\text{A}$
- * High Switching Speed

SYMBOL

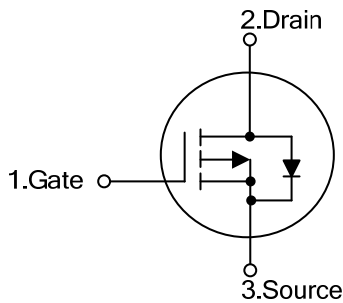

ORDERING INFORMATION

Ordering Number		Package	Pin Assignment			Packing
Lead Free	Halogen Free		1	2	3	
UTT50P06L-TA3-T	UTT50P06G-TA3-T	TO-220	G	D	S	Tube
UTT50P06L-TF3-T	UTT50P06G-TF3-T	TO-220F	G	D	S	Tube
UTT50P06L-TN3-R	UTT50P06G-TN3-R	TO-252	G	D	S	Tape Reel
UTT50P06L-T2Q-T	UTT50P06G-T2Q-T	TO-262	G	D	S	Tube
UTT50P06L-TQ2-T	UTT50P06G-TQ2-T	TO-263	G	D	S	Tube
UTT50P06L-TQ2-R	UTT50P06G-TQ2-R	TO-263	G	D	S	Tape Reel

Note: Pin Assignment: G: Gate D: Drain S: Source

<p>UTT50P06G-TA3-T</p> <p>(1)Packing Type</p> <p>(2)Package Type</p> <p>(3)Green Package</p>	<p>(1) T: Tube, R:Tape Reel</p> <p>(2) TF1: TO-220F1, TF3: TO-220F, TN3: TO-252, T2Q: TO-262, TQ2: TO-263</p> <p>(3) G: Halogen Free and Lead Free, L: Lead Free</p>
--	--

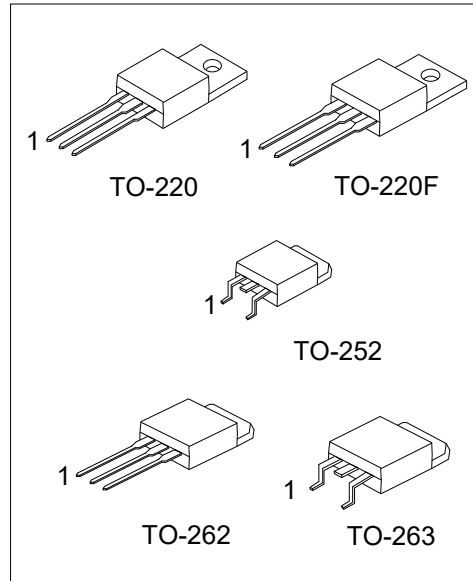

MARKING

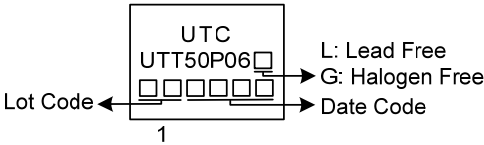

■ ABSOLUTE MAXIMUM RATINGS ($T_C=25^{\circ}\text{C}$, unless otherwise specified)

PARAMETER		SYMBOL	RATINGS	UNIT	
Drain-Source Voltage		V_{DSS}	-60	V	
Gate-Source Voltage		V_{GSS}	± 20	V	
Drain Current	Continuous	I_D	$T_C=25^{\circ}\text{C}$	-50	A
			$T_C=125^{\circ}\text{C}$	-27.5	A
Pulsed		I_{DM}	-100	A	
Avalanche Current		I_{AR}	-50	A	
Single Pulse Avalanche Energy (Note 2)		E_{AS}	145	mJ	
Power Dissipation ($T_C=25^{\circ}\text{C}$)	TO-220	P_D	160	W	
	TO-262				
	TO-263				
	TO-220F				
		TO-252	60	W	
Junction Temperature		T_J	-55 ~ +150	$^{\circ}\text{C}$	
Storage Temperature		T_{STG}	-55 ~ +150	$^{\circ}\text{C}$	

Notes: 1. Absolute maximum ratings are those values beyond which the device could be permanently damaged.

Absolute maximum ratings are stress ratings only and functional device operation is not implied.

2. Repetitive Rating: Pulse width limited by maximum junction temperature.

3. $L = 0.1\text{mH}$, $I_{AS} = 53.8\text{A}$, $V_{DD} = 30\text{V}$, $R_G = 25\Omega$, Starting $T_J = 25^{\circ}\text{C}$

4. $I_{SD} \leq 30\text{A}$, $di/dt \leq 200\text{A}/\mu\text{s}$, $V_{DD} \leq BV_{DSS}$, Starting $T_J = 25^{\circ}\text{C}$

■ THERMAL DATA

PARAMETER		SYMBOL	RATINGS	UNIT
Junction to Ambient	TO-220	θ_{JA}	62.5	$^{\circ}\text{C}/\text{W}$
	TO-220F			
	TO-262			
	TO-263			
		TO-252	110	$^{\circ}\text{C}/\text{W}$
Junction to Case	TO-220	θ_{JC}	0.78	$^{\circ}\text{C}/\text{W}$
	TO-262			
	TO-263			
	TO-220F			
		TO-252	2.08 (Note)	$^{\circ}\text{C}/\text{W}$

Note: Device mounted on FR-4 substrate P_C board, 2oz copper, with 1inch square copper plate.

■ ELECTRICAL CHARACTERISTICS (T_J=25°C, unless otherwise specified)

PARAMETER		SYMBOL	TEST CONDITIONS	MIN	TYP	MAX	UNIT
OFF CHARACTERISTICS							
Drain-Source Breakdown Voltage		BV _{DSS}	V _{GS} =0V, I _D =-250μA	-60			V
Drain-Source Leakage Current		I _{DSS}	V _{DS} =-60V, V _{GS} =0V			-1	μA
Gate Threshold Voltage		V _{GS(TH)}	V _{DS} =V _{GS} , I _D =-250μA	-1.0		-3.0	V
Gate- Source Leakage Current	Forward	I _{GSS}	V _{GS} =+20V, V _{DS} =0V			+100	nA
	Reverse		V _{GS} =-20V, V _{DS} =0V			-100	nA
ON CHARACTERISTICS							
Static Drain-Source On-State Resistance (Note 1)		R _{DS(ON)}	V _{GS} =-10V, I _D =-17A			15	mΩ
			V _{GS} =-4.5V, I _D =-14A			20	mΩ
DYNAMIC PARAMETERS (Note 2)							
Input Capacitance		C _{ISS}	V _{GS} =0V, V _{DS} =-25V, f=1MHz		5140		pF
Output Capacitance		C _{OSS}			390		pF
Reverse Transfer Capacitance		C _{RSS}			286		pF
SWITCHING PARAMETERS (Note 1,2,3)							
Total Gate Charge		Q _G	V _{DS} =-48V, V _{GS} =-10V, I _D =-50A		96		nC
Gate to Source Charge		Q _{GS}			13		nC
Gate to Drain Charge		Q _{GD}			21		nC
Turn-ON Delay Time		t _{D(ON)}	V _{DD} =-30V, V _{GS} =-10V, I _D =-50A, R _G =3.3Ω		12		ns
Rise Time		t _R			19		ns
Turn-OFF Delay Time		t _{D(OFF)}			130		ns
Fall-Time		t _F			63		ns
SOURCE- DRAIN DIODE RATINGS AND CHARACTERISTICS (T_C=25°C) (Note 2)							
Maximum Body-Diode Continuous Current		I _S				-50	A
Maximum Body-Diode Pulsed Current		I _{SM}				-80	A
Drain-Source Diode Forward Voltage (Note 1)		V _{SD}	I _F =-50A, V _{GS} =0V			-1.6	V
Body Diode Reverse Recovery Time		t _{rr}	I _F =-30A, dI/dt=100A/μs		60		ns
Body Diode Reverse Recovery Charge		Q _{rr}			80		nC

Notes: 1. Pulse Test : Pulse width ≤ 300μs, Duty cycle ≤ 2%.

2. Guaranteed by design, not subject to production testing.

3. Independent of operating temperature.

■ TEST CIRCUITS AND WAVEFORMS

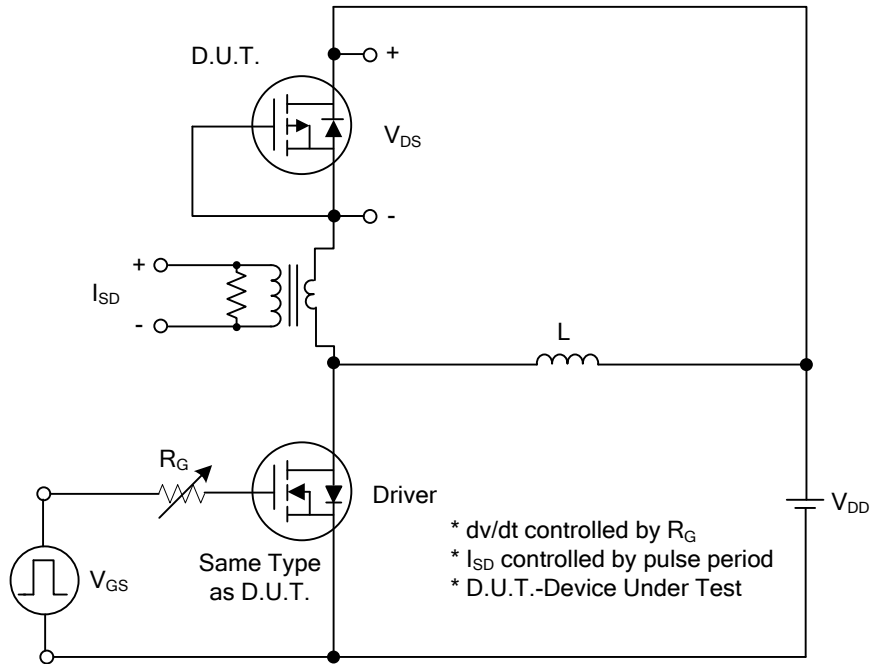

Peak Diode Recovery dv/dt Test Circuit

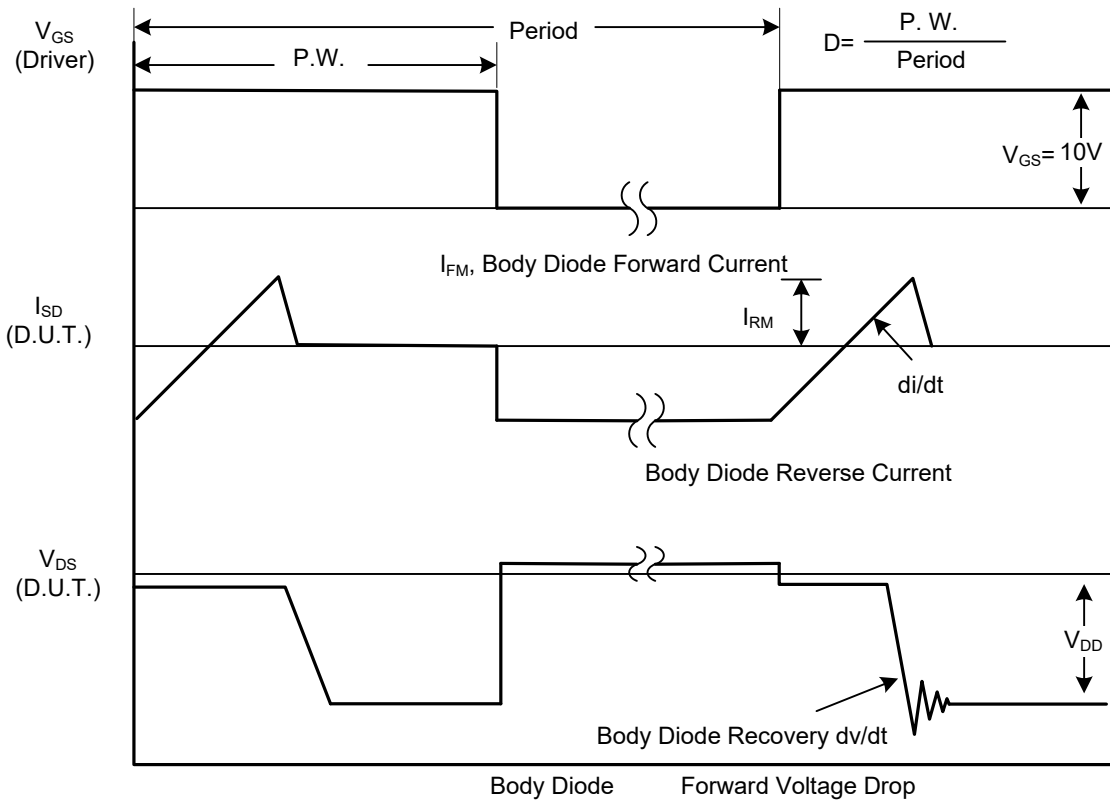

Peak Diode Recovery dv/dt Waveforms

TEST CIRCUITS AND WAVEFORMS

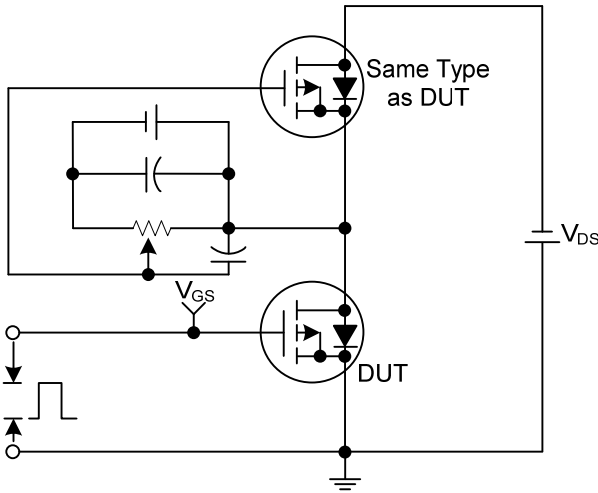

Gate Charge Test Circuit

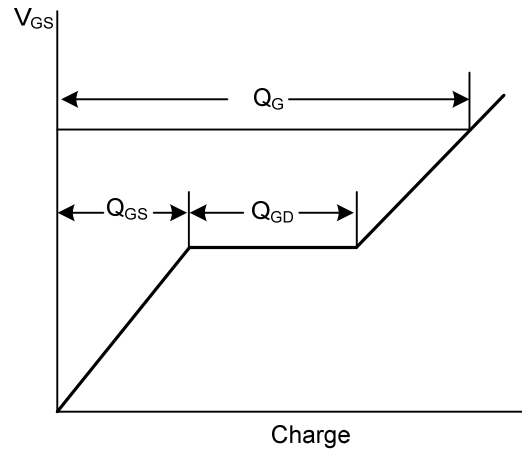

Gate Charge Waveforms

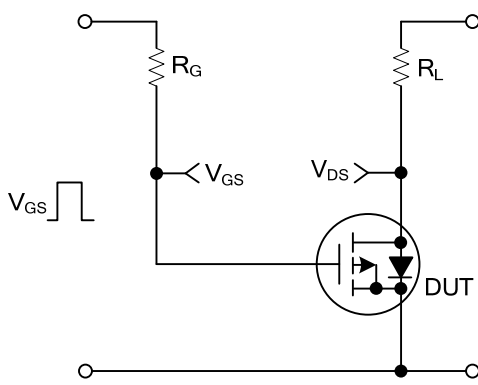

Resistive Switching Test Circuit

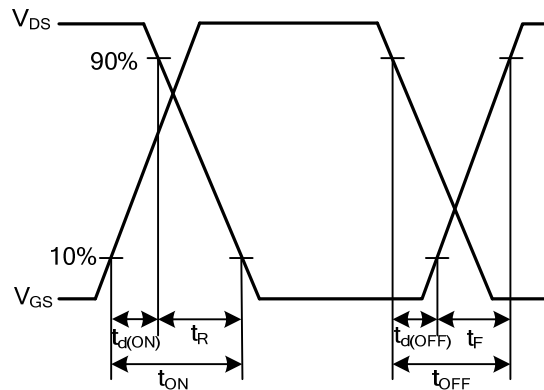

Resistive Switching Waveforms

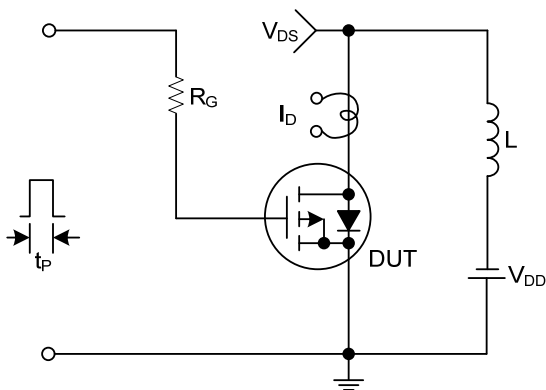

Unclamped Inductive Switching Test Circuit

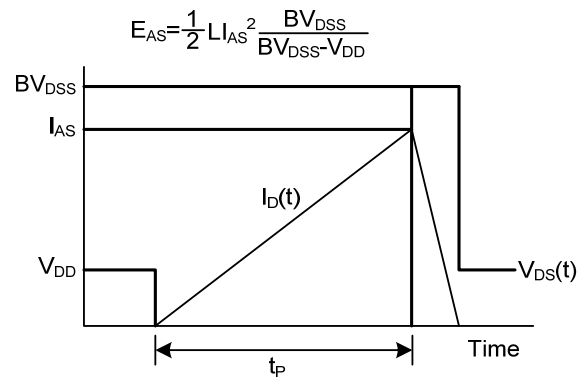

Unclamped Inductive Switching Waveforms

TYPICAL CHARACTERISTICS

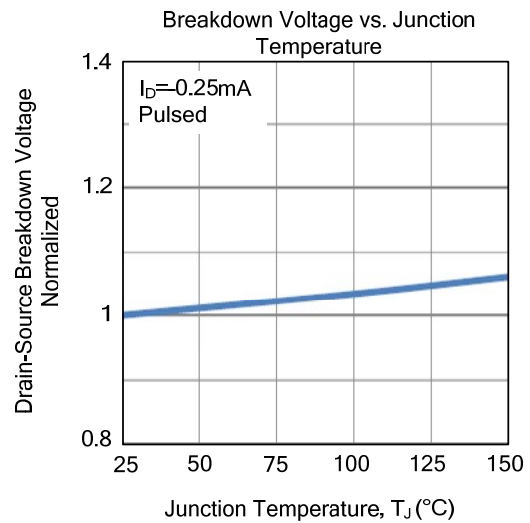
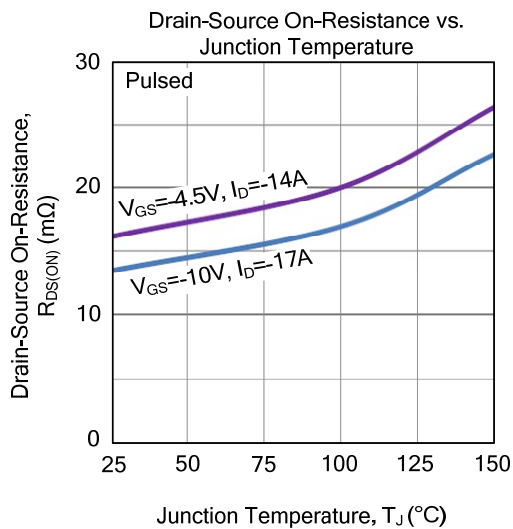
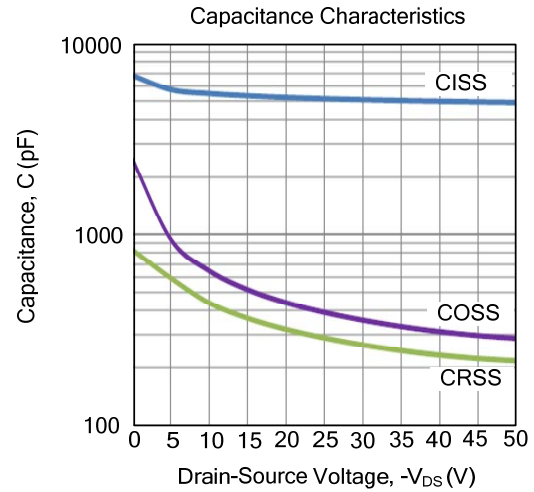
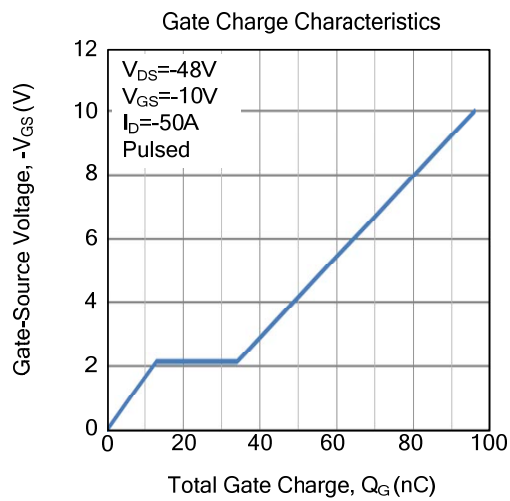
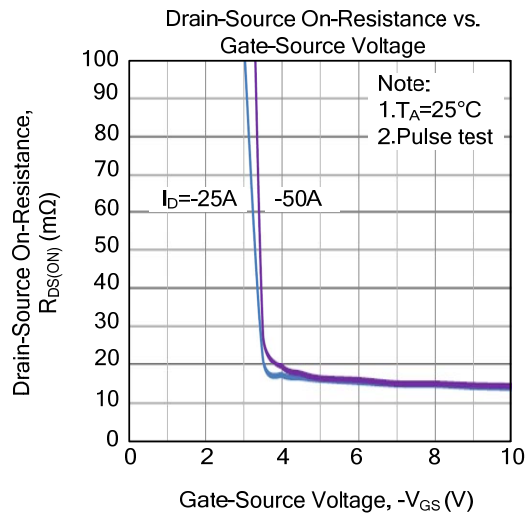
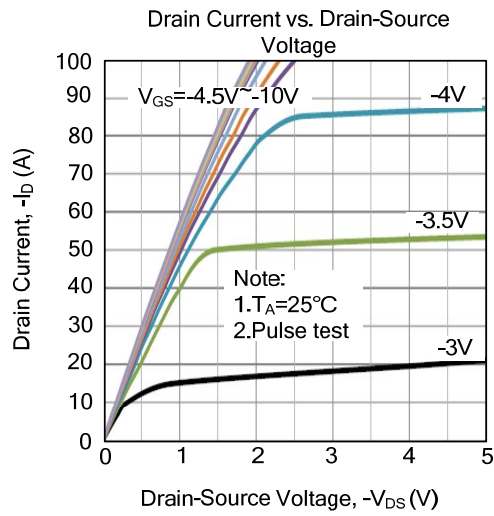

TYPICAL CHARACTERISTICS (Cont.)

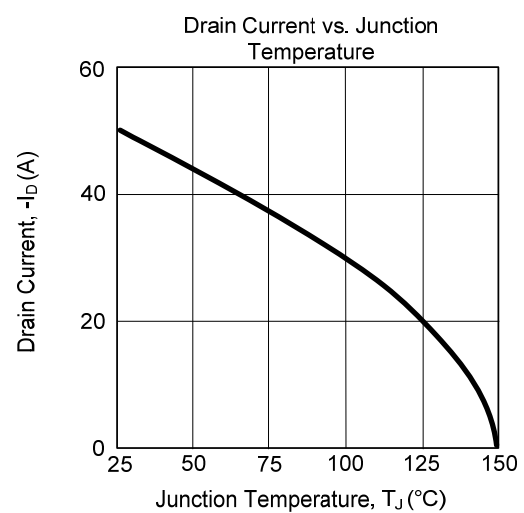
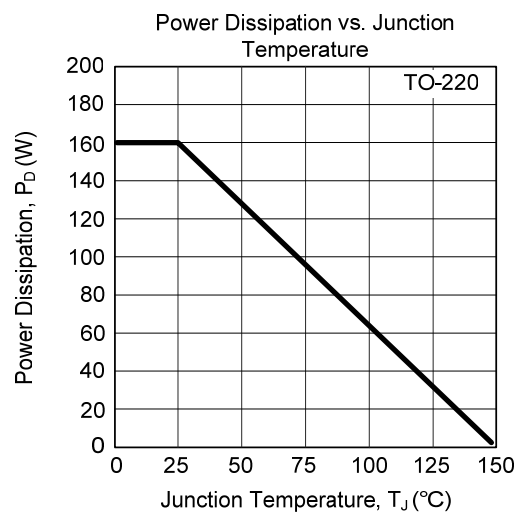
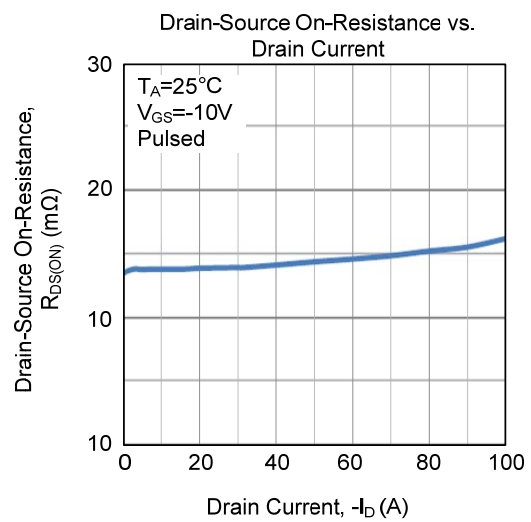
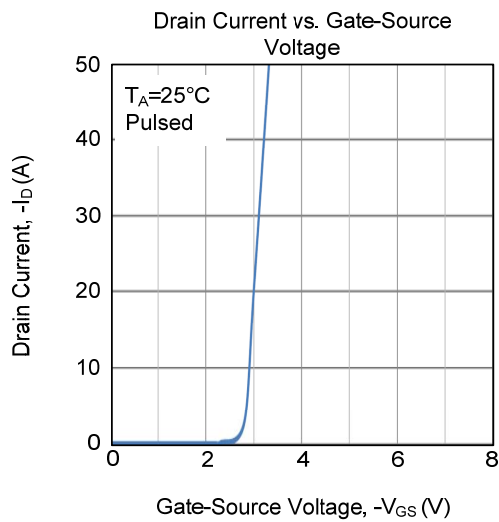
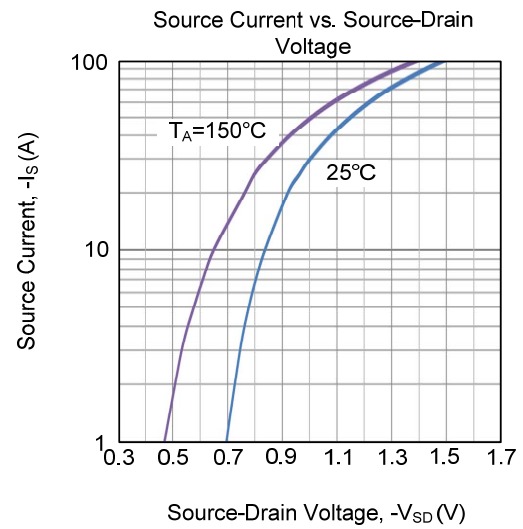
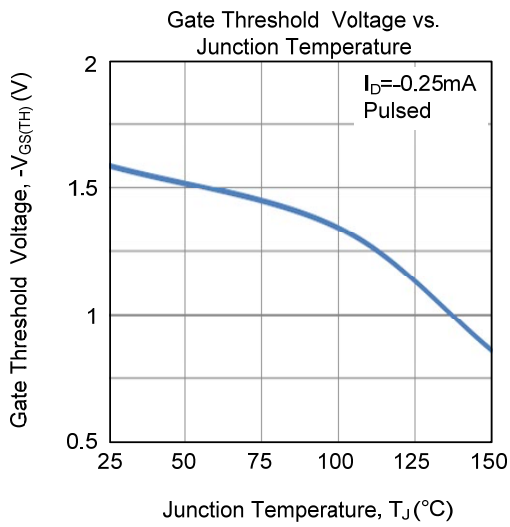

■ TYPICAL CHARACTERISTICS (Cont.)

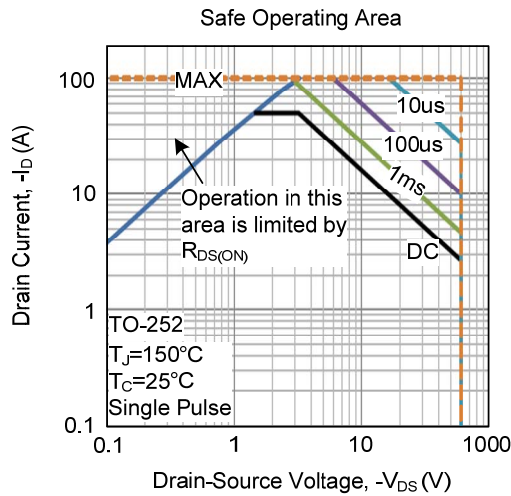

UTC assumes no responsibility for equipment failures that result from using products at values that exceed, even momentarily, rated values (such as maximum ratings, operating condition ranges, or other parameters) listed in products specifications of any and all UTC products described or contained herein. UTC products are not designed for use in life support appliances, devices or systems where malfunction of these products can be reasonably expected to result in personal injury. Reproduction in whole or in part is prohibited without the prior written consent of the copyright owner. UTC reserves the right to make changes to information published in this document, including without limitation specifications and product descriptions, at any time and without notice. This document supersedes and replaces all information supplied prior to the publication hereof.

X-ON Electronics

Largest Supplier of Electrical and Electronic Components

Click to view similar products for [MOSFET](#) category:

Click to view products by [Unisonic](#) manufacturer:

Other Similar products are found below :

[IRFD120](#) [JANTX2N5237](#) [BUK455-60A/B](#) [MIC4420CM-TR](#) [VN1206L](#) [NDP4060](#) [SI4482DY](#) [IPS70R2K0CEAKMA1](#) [SQD23N06-31L-GE3](#)
[TK16J60W,S1VQ\(O](#) [2SK2614\(TE16L1,Q\)](#) [DMN1017UCP3-7](#) [DMN1053UCP4-7](#) [SQJ469EP-T1-GE3](#) [NTE2384](#) [DMC2700UDMQ-7](#)
[DMN2080UCB4-7](#) [DMN61D9UWQ-13](#) [US6M2GTR](#) [DMN31D5UDJ-7](#) [DMP22D4UFO-7B](#) [DMN1006UCA6-7](#) [DMN16M9UCA6-7](#)
[STF5N65M6](#) [IRF40H233XTMA1](#) [STU5N65M6](#) [DMN6022SSD-13](#) [DMN13M9UCA6-7](#) [DMTH10H4M6SPS-13](#) [DMN2990UFB-7B](#)
[IPB80P04P405ATMA2](#) [2N7002W-G](#) [MCAC30N06Y-TP](#) [MCQ7328-TP](#) [NTMC083NP10M5L](#) [NVMFS2D3P04M8LT1G](#) [BXP7N65D](#)
[BXP4N65F](#) [AOL1454G](#) [WMJ80N60C4](#) [BXP2N20L](#) [BXP2N65D](#) [BXT1150N10J](#) [BXT1700P06M](#) [TSM60NB380CP](#) [ROG](#) [RQ7L055BGTCR](#)
[DMNH15H110SK3-13](#) [SLF10N65ABV2](#) [BSO203SP](#) [BSO211P](#)