



UZ1085

LINEAR INTEGRATED CIRCUIT

3A ADJUSTABLE/FIXED LOW DROPOUT LINEAR REGULATOR

DESCRIPTION

The UTC **UZ1085-xx** series are low dropout three-terminal regulators with 3A output current capability. These devices have been optimized for low voltage applications including VTT bus termination, where transient response and minimum input voltage are critical.

Current limit is trimmed to ensure specified output current and controlled short-circuit current. On-chip thermal limiting provides protection against any combination of overload and ambient temperature that would create excessive junction temperatures.

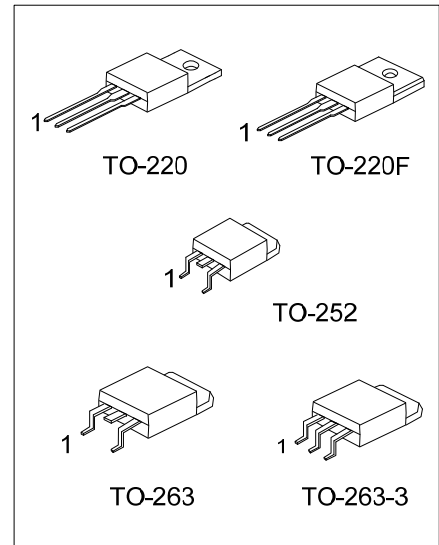

FEATURES

- *Fast transient response
- *Low dropout voltage at up to 3A
- *Load regulation:0.05% typical
- *Trimmed current limit
- *On-chip thermal limiting

ORDERING INFORMATION

Ordering Number		Package	Pin Assignment			Packing
Lead Free	Halogen Free		1	2	3	
UZ1085L-xx-TA3-T	UZ1085G-xx-TA3-T	TO-220	A/G	O	I	Tube
UZ1085L-xx-TF3-T	UZ1085G-xx-TF3-T	TO-220F	A/G	O	I	Tube
UZ1085L-xx-TN3-R	UZ1085G-xx-TN3-R	TO-252	A/G	O	I	Tape Reel
UZ1085L-xx-TQ2-T	UZ1085G-xx-TQ2-T	TO-263	A/G	O	I	Tube
UZ1085L-xx-TQ2-R	UZ1085G-xx-TQ2-R	TO-263	A/G	O	I	Tape Reel
UZ1085L-xx-TQ3-T	UZ1085G-xx-TQ3-T	TO-263-3	A/G	O	I	Tube
UZ1085L-xx-TQ3-R	UZ1085G-xx-TQ3-R	TO-263-3	A/G	O	I	Tape Reel

Note: 1. xx: Output Voltage, refer to Marking Information.

2. A: ADJ (for adjustable regulator), G: GND (for fixed regulator), O: V_{OUT} , I: V_{IN}

<p>UZ1085G-xx-TA3-T</p> <p>(1)Packing Type (2)Package Type (3)Output Voltage Code (4)Green Package</p>	<p>(1) T: Tube, R: Tape Reel (2) TA3: TO-220, TF3: TO-220F, TN3: TO-252 TQ2: TO-263, TQ3: TO-263-3 (3) xx: refer to Marking Information (4) G: Halogen Free and Lead Free, L: Lead Free</p>
--	---

UZ1085

LINEAR INTEGRATED CIRCUIT

MARKING INFORMATION

PACKAGE	VOLTAGE CODE	MARKING
TO-220	15 : 1.5V	<p>UTC UZ1085 XX □ □ □ □ □ □ 1</p> <p>Lot Code ← → Date Code Voltage Code ← →</p> <p>L: Lead Free G: Halogen Free</p>
TO-220F	18 : 1.8V	
TO-252	25 : 2.5V	
TO-263	33 : 3.3V	
TO-263-3	50 : 5.0V	
	AD:ADJ	

BLOCK DIAGRAM

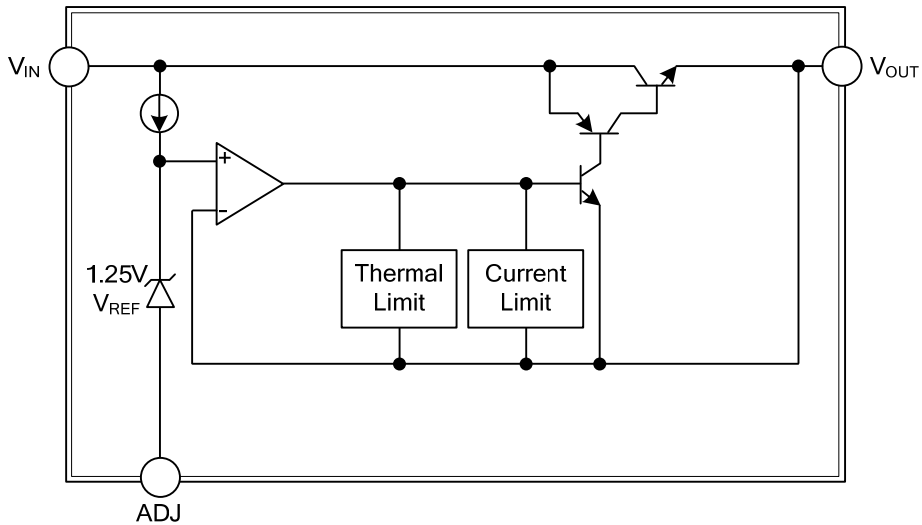

For Adjustable Voltage

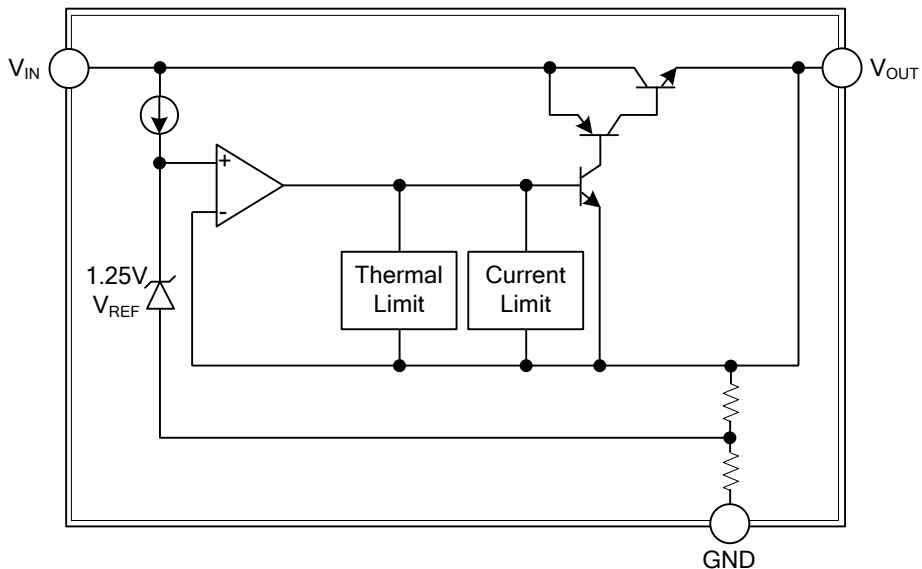

For Fixed Voltage

■ ABSOLUTE MAXIMUM RATINGS

PARAMETER	SYMBOL	RATINGS	UNIT
Input Voltage	V_{IN}	18	V
Junction Temperature	T_J	+125	°C
Operating Temperature	T_{OPR}	-40 ~ +125	°C
Storage Temperature	T_{STG}	-40 ~ +150	°C

Note: Absolute maximum ratings are those values beyond which the device could be permanently damaged.

Absolute maximum ratings are stress ratings only and functional device operation is not implied.

■ THERMAL DATA

PARAMETER	SYMBOL	RATINGS	UNIT
Junction to Ambient	TO-252	118	°C/W
	TO-220/TO-220F	62	
	TO-263/ TO-263-3		
Junction to Case	TO-252	12	°C/W
	TO-220/TO-263	4	
	TO-263-3		
	TO-220F	7.6	

■ ELECTRICAL CHARACTERISTICS ($C_{OUT}=22\mu F$, $T_A=25^\circ C$, unless otherwise specified.)

For UZ1085-ADJ (Adjustable)

PARAMETER	SYMBOL	TEST CONDITIONS	MIN	TYP	MAX	UNIT
Reference Voltage	V_{REF}	$1.5V \leq (V_{IN} - V_{OUT}) \leq 8.25V, 10mA \leq I_{OUT} \leq 3A$	1.225	1.25	1.275	V
Line Regulation	ΔV_{OUT}	$(V_{OUT} + 1.5V) \leq V_{IN} \leq 12V, I_{OUT} = 10mA$		0.005	0.2	%
Load Regulation	ΔV_{OUT}	$(V_{IN} - V_{OUT}) = 3V, 10mA \leq I_{OUT} \leq 3A$		0.05	0.5	%
Dropout Voltage	V_D	$\Delta V_{REF}\% = 1\%, I_{OUT} = 3A$		1.30	1.40	V
Current Limit	I_{LIMIT}	$(V_{IN} - V_{OUT}) = 2V$	3.1	4		A
Adjust Pin Current	I_{ADJ}			35	120	μA
Adjust Pin Current Change	ΔI_{ADJ}	$1.5V \leq (V_{IN} - V_{OUT}) \leq 12V, 10mA \leq I_{OUT} \leq 3A$		0.2	5	μA
Minimum Load Current	$I_{O(MIN)}$	$1.5V \leq (V_{IN} - V_{OUT}) \leq 12V$			10	mA
Quiescent Current	I_Q	$V_{IN} = 12V$		4	13	mA
Ripple Rejection	RR	$f = 120Hz, \text{Tantalum}, (V_{IN} - V_{OUT}) = 3V, I_{OUT} = 3A$	60	72		dB
Thermal Regulation		$T_A = 25^\circ C, 30ms \text{ pulse}$		0.004	0.02	%/W
Temperature Stability	ΔV_{OUT}			0.5		%
Long-Term Stability	ΔV_{OUT}	$T_A = 125^\circ C, 1000hr$		0.03	1.0	%
Output Noise(% of V_{OUT})	eN	$T_A = 25^\circ C, 10Hz \leq f \leq 10kHz$		0.003		%
Thermal Shutdown				150		°C

- ELECTRICAL CHARACTERISTICS ($T_A=25^\circ\text{C}$, $C_{OUT}=22\mu\text{F}$, unless otherwise specified.)

For UZ1085-xx (Fixed Voltage)

PARAMETER	SYMBOL	TEST CONDITIONS	MIN	TYP	MAX	UNIT	
Output Voltage	UZ1085-15	V_{OUT}	$3.0\text{V} \leq V_{IN} \leq 8.5\text{V}$, $10\text{mA} \leq I_{OUT} \leq 3\text{A}$	1.470	1.5	1.530	V
	UZ1085-18		$3.3\text{V} \leq V_{IN} \leq 8.8\text{V}$, $10\text{mA} \leq I_{OUT} \leq 3\text{A}$	1.764	1.8	1.830	V
	UZ1085-25		$4.0\text{V} \leq V_{IN} \leq 9.5\text{V}$, $10\text{mA} \leq I_{OUT} \leq 3\text{A}$	2.450	2.5	2.550	V
	UZ1085-33		$4.8\text{V} \leq V_{IN} \leq 10.3\text{V}$, $10\text{mA} \leq I_{OUT} \leq 3\text{A}$	3.234	3.3	3.366	V
	UZ1085-50		$6.5\text{V} \leq V_{IN} \leq 12\text{V}$, $10\text{mA} \leq I_{OUT} \leq 3\text{A}$	4.900	5.0	5.100	V
Line Regulation	ΔV_{OUT}	$(V_{OUT} + 1.5\text{V}) \leq V_{IN} \leq 12\text{V}$, $I_{OUT} = 10\text{mA}$		0.005	0.2	%	
Load Regulation	ΔV_{OUT}	$(V_{IN} - V_{OUT}) = 3\text{V}$, $10\text{mA} \leq I_{OUT} \leq 3\text{A}$		0.05	0.5	%	
Dropout Voltage	V_D	$\Delta V_{REF}\% = 1\%$, $I_{OUT} = 3\text{A}$		1.30	1.40	V	
Current Limit	I_{LIMIT}	$(V_{IN} - V_{OUT}) = 2\text{V}$	3.1	4		A	
Minimum Load Current	$I_{O(MIN)}$	$1.5\text{V} \leq (V_{IN} - V_{OUT}) \leq 12\text{V}$			10	mA	
Quiescent Current	I_Q	$V_{IN} = 12\text{V}$		4	13	mA	
Ripple Rejection	RR	$f = 120\text{Hz}$, Tantalum, $(V_{IN} - V_{OUT}) = 3\text{V}$, $I_{OUT} = 3\text{A}$	60	72		dB	
Thermal Regulation		$T_A = 25^\circ\text{C}$, 30ms pulse		0.004	0.02	%/W	
Temperature Stability	ΔV_{OUT}	$T_A = 125^\circ\text{C}$, 1000hr		0.5		%	
Long-Term Stability	ΔV_{OUT}			0.03	1.0	%	
Output Noise(% of V_{OUT})	eN	$T_A = 25^\circ\text{C}$, $10\text{Hz} \leq f \leq 10\text{kHz}$		0.003		%	
Thermal shutdown				150		$^\circ\text{C}$	

■ TYPICAL APPLICATION CIRCUIT

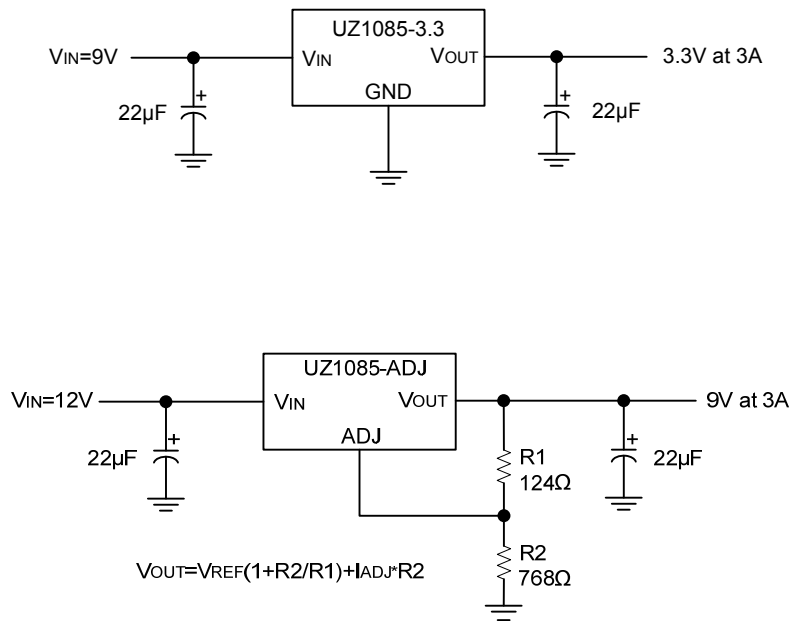

TYPICAL CHARACTERISTICS

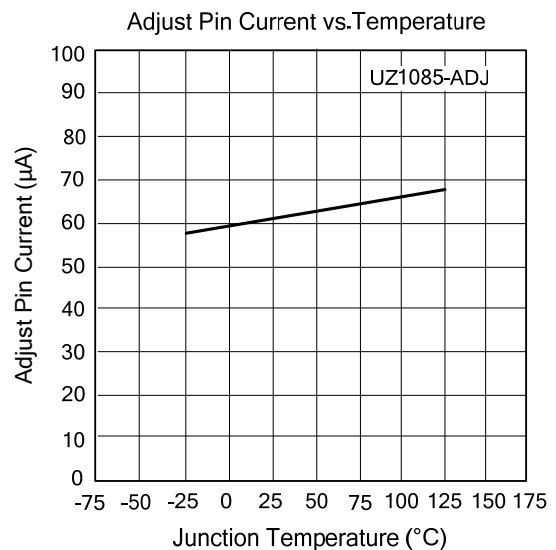
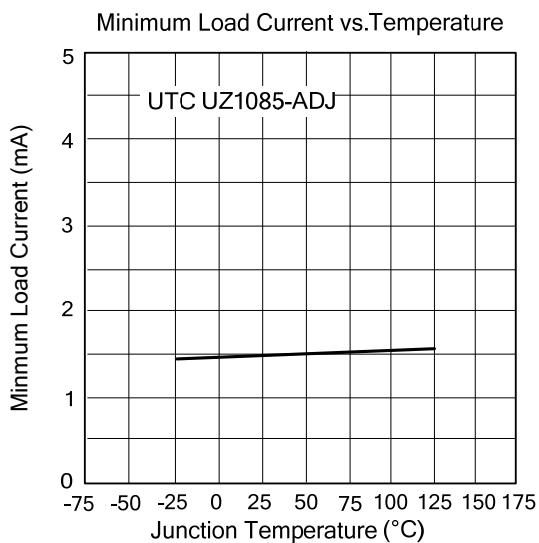
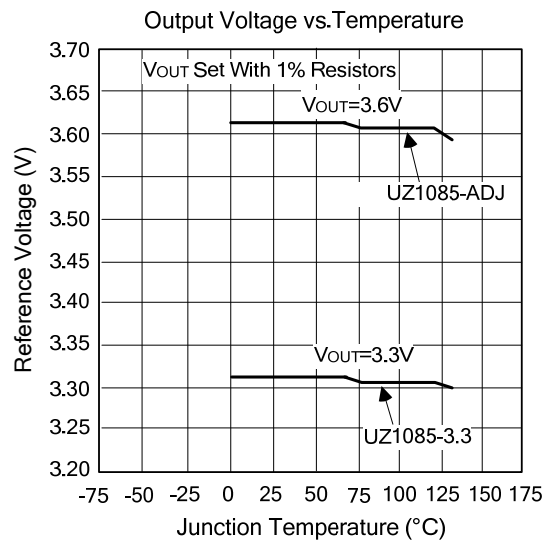
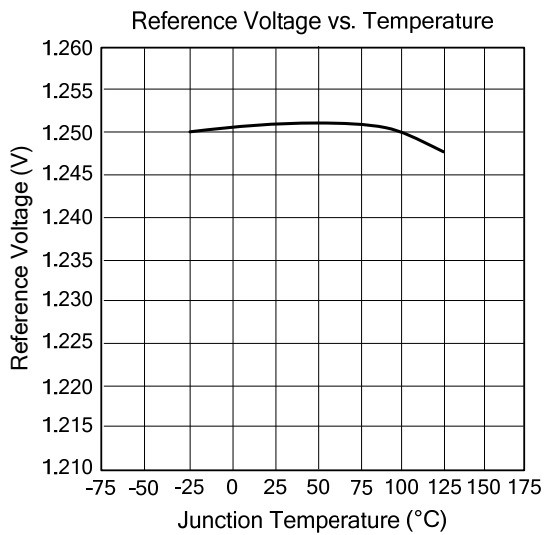
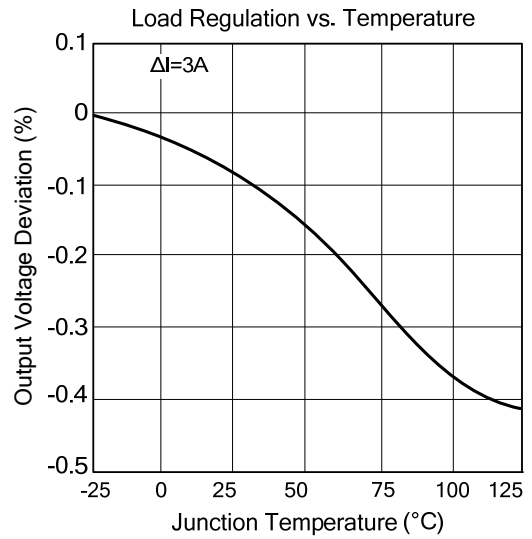
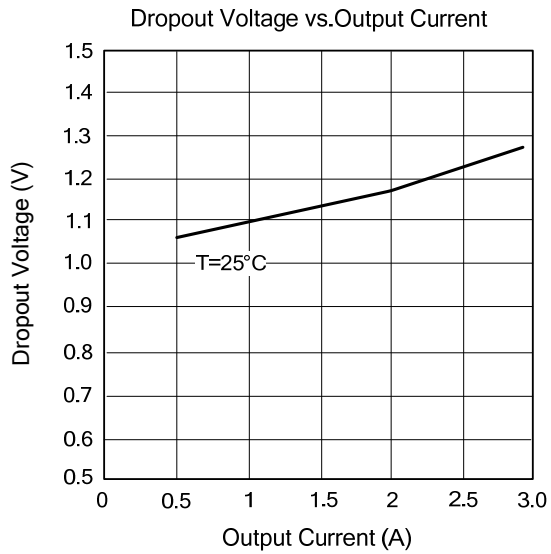

■ TYPICAL CHARACTERISTICS (Cont.)

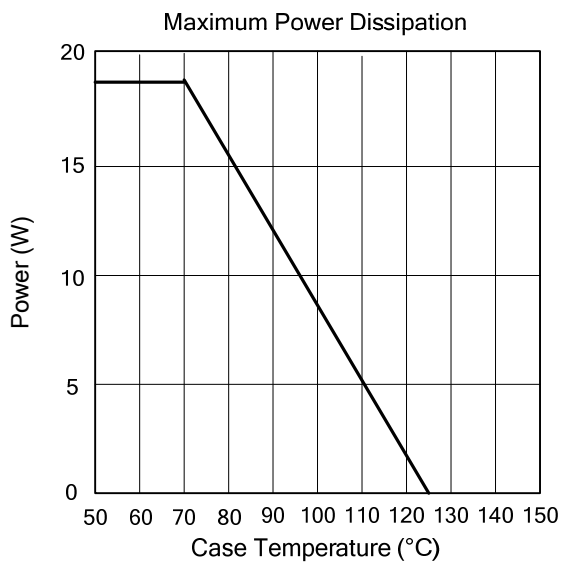
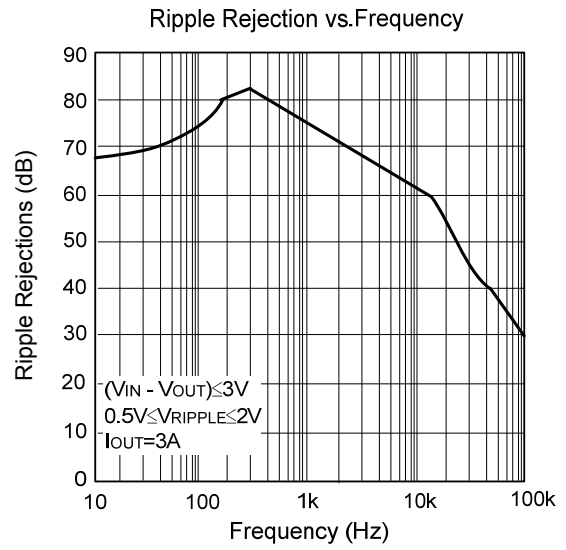
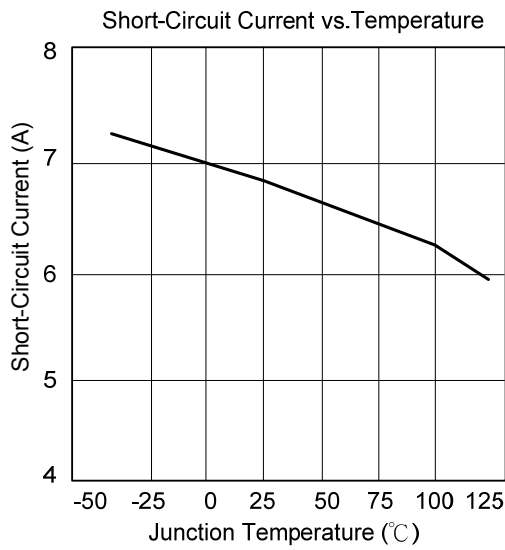

UTC assumes no responsibility for equipment failures that result from using products at values that exceed, even momentarily, rated values (such as maximum ratings, operating condition ranges, or other parameters) listed in products specifications of any and all UTC products described or contained herein. UTC products are not designed for use in life support appliances, devices or systems where malfunction of these products can be reasonably expected to result in personal injury. Reproduction in whole or in part is prohibited without the prior written consent of the copyright owner. UTC reserves the right to make changes to information published in this document, including without limitation specifications and product descriptions, at any time and without notice. This document supersedes and replaces all information supplied prior to the publication hereof.

X-ON Electronics

Largest Supplier of Electrical and Electronic Components

Click to view similar products for [Linear Voltage Regulators](#) category:

Click to view products by [Unisonic](#) manufacturer:

Other Similar products are found below :

[LV5684PVD-XH](#) [MCDTSA6-2R](#) [L7815ACV-DG](#) [714954EB](#) [ZMR500QFTA](#) [BA033LBSG2-TR](#) [LV5680P-E](#) [L79M05T-E](#) [L78LR05D-MA-E](#) [NCV317MBTG](#) [NTE7227](#) [MP2018GZD-33-P](#) [MP2018GZD-5-P](#) [LV5680NPVC-XH](#) [LT1054CN8](#) [ZTS6538SE](#) [UA78L09CLP](#) [UA78L09CLPR](#) [CAT6221-PPTD-GT3](#) [MC78M09CDTRK](#) [NCV51190MNTAG](#) [78M05](#) [HT7150-1](#) [UM1540DB-18](#) [XC6234H281VR-G](#) [WL2834CA-6/TR](#) [TPL730F33-5TR](#) [TLS850F1TA](#) [V50](#) [TPS549B22RVFR](#) [UM1540DB-33](#) [WL9200P3-50B](#) [WL9100P3-33B](#) [WL9005D4-33](#) [XC6219B152MR](#) [WL2855K33-3/TR](#) [PJ54BM33SE](#) [PJ9500M25SA](#) [MD7218E33PC1](#) [H7533-2PR](#) [SK7812AU](#) [SD1A30](#) [78L33](#) [TP78L33T3](#) [L78L33ACUTR](#) [SK6513ST3A-50](#) [SK6054D4-09](#) [SK6054D4-18](#) [SK6054D4-11](#) [SK6054D4-10](#) [LM79L12F](#)