

Description

United Silicon Carbide, Inc. offers the 3rd generation of high performance SiC Merged-PiN-Schottky (MPS) diodes. With zero reverse recovery charge and 175°C maximum junction temperature, these diodes are ideally suited for high frequency and high efficiency power systems with minimum cooling requirements.

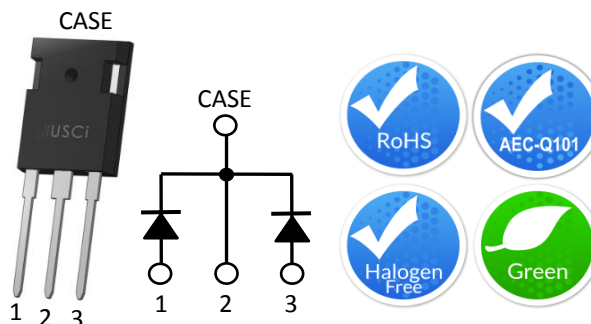

Part Number	Package	Marking
UJ3D06520KSD	TO-247-3L	UJ3D06520KSD

Features

- ◆ 175°C maximum operating junction temperature
- ◆ Easy paralleling
- ◆ Extremely fast switching not dependent on temperature
- ◆ No reverse or forward recovery
- ◆ Enhanced surge current capability, MPS structure
- ◆ Excellent thermal performance, Ag sintered
- ◆ 100% UIS tested
- ◆ AEC-Q101 qualified

Typical Applications

- ◆ Power converters
- ◆ Industrial motor drives
- ◆ Switching-mode power supplies
- ◆ Power factor correction modules

Maximum Ratings

Parameter	Symbol	Test Conditions	Value (Leg/Device)	Units
DC blocking voltage	V_R		650	V
Repetitive peak reverse voltage, $T_j=25^\circ\text{C}$	V_{RRM}		650	V
Surge peak reverse voltage	V_{RSM}		650	V
Maximum DC forward current	I_F	$T_C = 152^\circ\text{C}$	10/20	A
Non-repetitive forward surge current sine halfwave	I_{FSM}	$T_C = 25^\circ\text{C}, t_p = 10\text{ms}$	70/140	A
		$T_C = 110^\circ\text{C}, t_p = 10\text{ms}$	60/120	
Repetitive forward surge current sine halfwave, $D=0.1$	I_{FRM}	$T_C = 25^\circ\text{C}, t_p = 10\text{ms}$	45.9/91.8	A
		$T_C = 110^\circ\text{C}, t_p = 10\text{ms}$	28.7/57.4	
Non-repetitive peak forward current	$I_{F,max}$	$T_C = 25^\circ\text{C}, t_p = 10\mu\text{s}$	455/910	A
		$T_C = 110^\circ\text{C}, t_p = 10\mu\text{s}$	455/910	
i^2t value	$\int i^2 dt$	$T_C = 25^\circ\text{C}, t_p = 10\text{ms}$	24.5/98	A^2s
		$T_C = 110^\circ\text{C}, t_p = 10\text{ms}$	18/72	
Power dissipation	P_{Tot}	$T_C = 25^\circ\text{C}$	136.4/272.8	W
		$T_C = 152^\circ\text{C}$	20.9/41.8	
Maximum junction temperature	$T_{J,max}$		175	$^\circ\text{C}$
Operating and storage temperature	T_J, T_{STG}		-55 to 175	$^\circ\text{C}$
Soldering temperatures, wavesoldering only allowed at leads	T_{sold}	1.6mm from case for 10s	260	$^\circ\text{C}$

Electrical Characteristics

T_J = +25°C unless otherwise specified

Parameter	Symbol	Test Conditions	Value (Leg/Device)			Units
			Min	Typ	Max	
Forward voltage	V _F	I _F = 10/20A, T _J = 25°C	-	1.5	1.7	V
		I _F = 10/20A, T _J =150°C	-	1.68	2	
		I _F = 10/20A, T _J =175°C	-	1.75	2.1	
Reverse current	I _R	V _R =650V, T _J =25°C	-	10/20	60/120	µA
		V _R =650V, T _J =175°C	-	150/300		
Total capacitive charge ⁽¹⁾	Q _C	V _R =400V		23/46		nC
Total capacitance	C	V _R =1V, f=1MHz		327/654		pF
		V _R =300V, f=1MHz		38/76		
		V _R =600V, f=1MHz		34/68		
Capacitance stored energy	E _C	V _R =400V		3.4/6.8		µJ

(1) Q_C is independent on T_J, di_F/dt, and I_F as shown in the application note USCi_AN0011.

Thermal characteristics

Parameter	symbol	Test Conditions	Value (Leg/Device)			Units
			Min	Typ	Max	
Thermal resistance	R _{θJC}			0.82/0.41	1.1/0.55	°C/W

Typical Performance

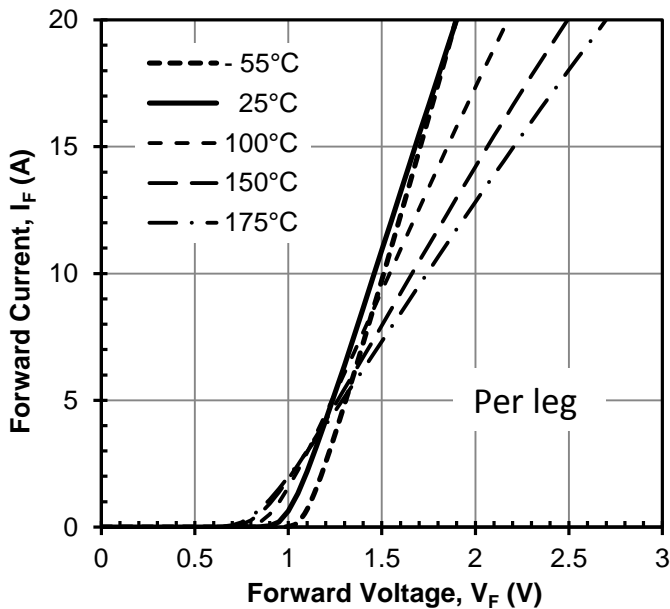

Figure 1 Typical forward characteristics per leg

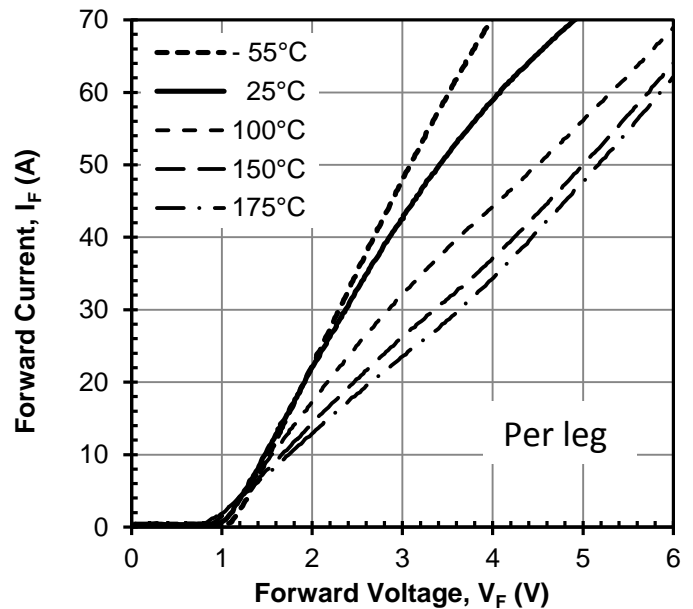

Figure 2 Typical forward characteristics in surge current per leg

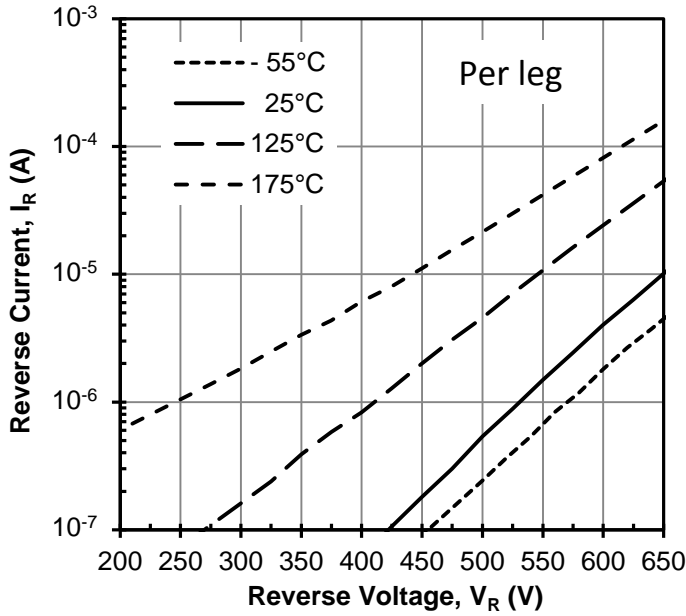

Figure 3 Typical reverse characteristics per leg

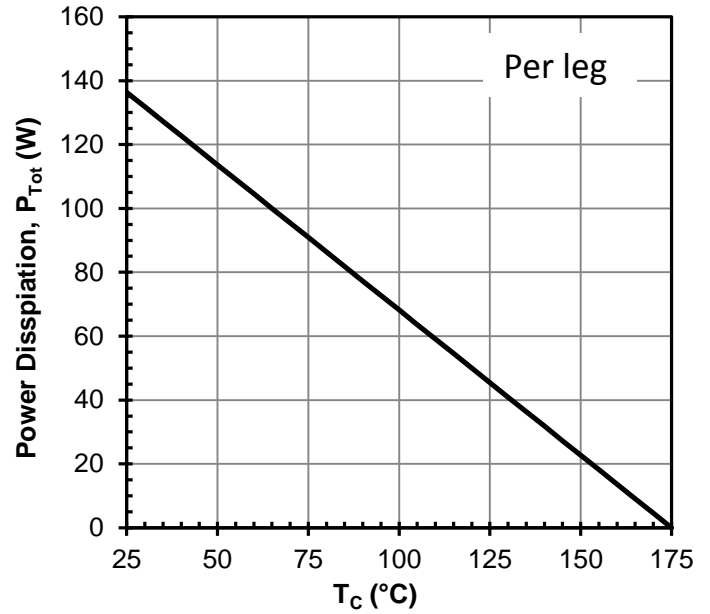

Figure 4 Power dissipation per leg

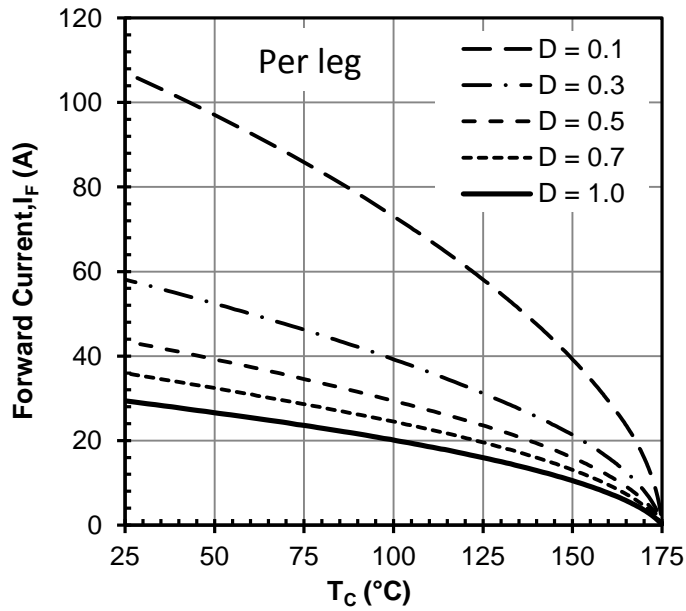

Figure 5 Diode forward current per leg

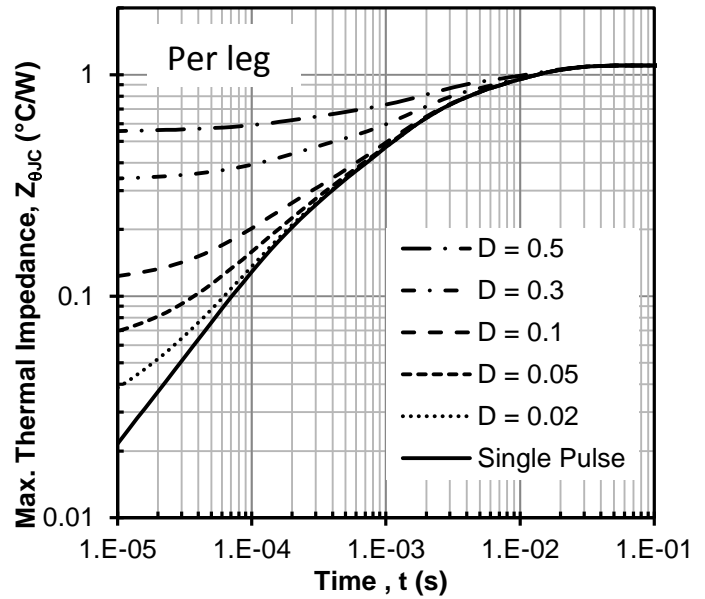

Figure 6 Maximum transient thermal impedance per leg

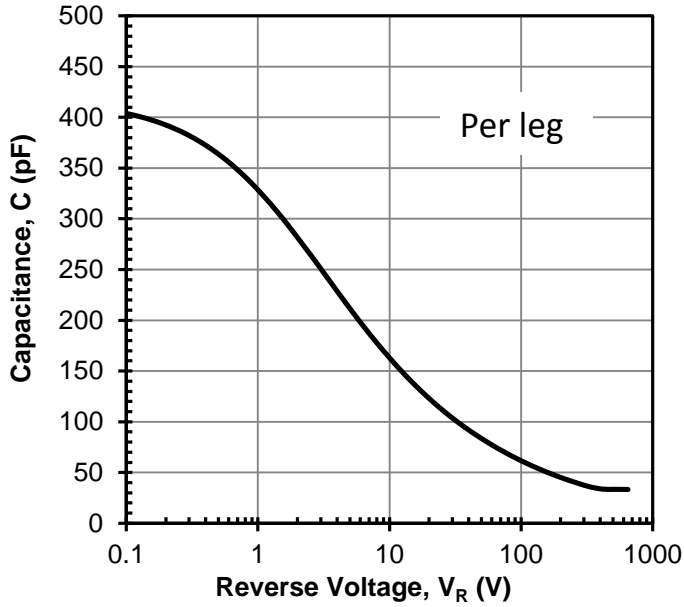

Figure 7 Capacitance per leg vs. reverse voltage at 1MHz

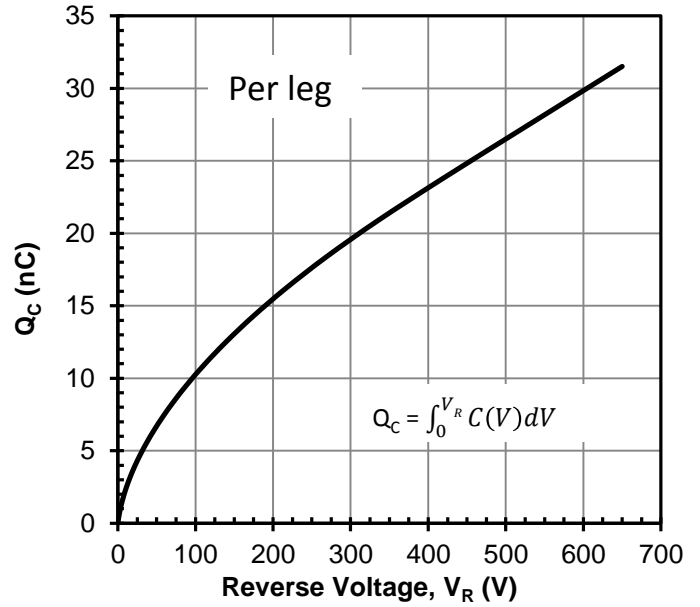

Figure 8 Typical capacitive charge per leg vs. reverse voltage

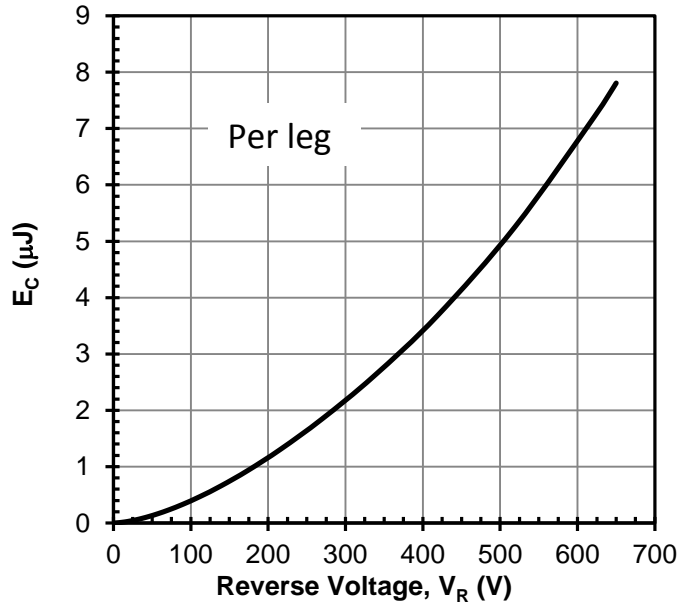

Figure 9 Typical capacitance stored energy per leg vs. reverse voltage

Disclaimer

United Silicon Carbide, Inc. reserves the right to change or modify any of the products and their inherent physical and technical specifications without prior notice. United Silicon Carbide, Inc. assumes no responsibility or liability for any errors or inaccuracies within.

Information on all products and contained herein is intended for description only. No license, express or implied, to any intellectual property rights is granted within this document.

United Silicon Carbide, Inc. assumes no liability whatsoever relating to the choice, selection or use of the United Silicon Carbide, Inc. products and services described herein.

X-ON Electronics

Largest Supplier of Electrical and Electronic Components

Click to view similar products for [Schottky Diodes & Rectifiers](#) category:

Click to view products by [UnitedSiC](#) manufacturer:

Other Similar products are found below :

[MA4E2039](#) [D1FH3-5063](#) [MBR10100CT-BP](#) [MBR1545CT](#) [MMBD301M3T5G](#) [RB160M-50TR](#) [RB551V-30](#) [BAS16E6433HTMA1](#) [BAT](#)
[54-02LRH E6327](#) [NSR05F40QNXT5G](#) [NTE555](#) [JANS1N6640](#) [SB07-03C-TB-H](#) [SK310-T](#) [SK32A-LTP](#) [SK33A-TP](#) [SK34B-TP](#) [SS3003CH-](#)
[TL-E](#) [GA01SHT18](#) [CRS10I30A\(TE85L,QM](#) [MA4E2501L-1290](#) [MBRA140TRPBF](#) [MBRB30H30CT-1G](#) [SB007-03C-TB-E](#) [SK32A-TP](#)
[SK33B-TP](#) [SK35A-TP](#) [SK38B-TP](#) [NRVBM120LT1G](#) [NTE505](#) [NTSB30U100CT-1G](#) [SS15E-TP](#) [VS-6CWQ10FNHM3](#) [ACDBA1100LR-HF](#)
[ACDBA1200-HF](#) [ACDBA140-HF](#) [ACDBA2100-HF](#) [ACDBA3100-HF](#) [CDBQC0530L-HF](#) [CDBQC0240LR-HF](#) [BAT6202VH6327XTSA1](#)
[ACDBA340-HF](#) [ACDBA260LR-HF](#) [ACDBA1100-HF](#) [SK310B-TP](#) [MA4E2502L-1246](#) [MA4E2502H-1246](#) [NRVBM120ET1G](#)
[NSR01L30MXT5G](#) [NTE573](#)