

Features

- N+P Channel
- Enhancement mode
- Low on-resistance $R_{DS(on)}$ @ $V_{GS}=\pm 4.5V$
- Fast Switching
- Pb-free lead plating; RoHS compliant



| Part ID | Package Type | Marking | Tape and reel information |
|-------------|--------------|----------|---------------------------|
| VSO025C03MC | SOP8 | 025C03MC | 3000pcs/Reel |

| | | | |
|-----------------------------------|----|-----|----|
| V_{DS} | 30 | -30 | V |
| $R_{DS(on),TYP}@ V_{GS}=\pm 10V$ | 15 | 23 | mΩ |
| $R_{DS(on),TYP}@ V_{GS}=\pm 4.5V$ | 23 | 38 | mΩ |
| I_D | 10 | -8 | A |

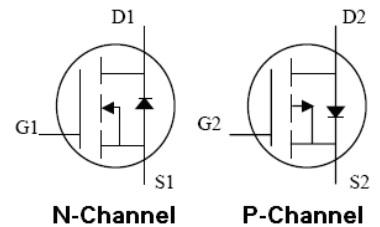
SOP8

Maximum ratings, at $T_A=25^\circ\text{C}$, unless otherwise specified

| Symbol | Parameter | Rating | | Unit | |
|---------------|---|-------------------------|------------|------------|------------------|
| | | NMOS | PMOS | | |
| $V_{(BR)DSS}$ | Drain-Source breakdown voltage | 30 | -30 | V | |
| I_S | Diode continuous forward current | $T_A=25^\circ\text{C}$ | 1.6 | -1.6 | A |
| I_D | Continuous drain current @ $V_{GS}=\pm 10V$ | $T_A=25^\circ\text{C}$ | 10 | -8 | A |
| | | $T_A=100^\circ\text{C}$ | 6 | -5 | A |
| I_{DM} | Pulse drain current tested ① | $T_A=25^\circ\text{C}$ | 40 | -32 | A |
| EAS | Avalanche energy, single pulsed ② | | 14 | 33 | mJ |
| P_D | Maximum power dissipation | $T_A=25^\circ\text{C}$ | 2 | 2 | W |
| V_{GS} | Gate-Source voltage | | ± 20 | ± 20 | V |
| MSL | | | Level 3 | | |
| $T_{STG} T_J$ | Storage and operating temperature range | | -55 to 150 | -55 to 150 | $^\circ\text{C}$ |

Thermal Characteristics

| Symbol | Parameter | Typical | Unit |
|-----------------|--|---------|--------------------|
| $R_{\theta JL}$ | Thermal Resistance-Junction to Lead | 40 | $^\circ\text{C/W}$ |
| $R_{\theta JA}$ | Thermal Resistance-Junction to Ambient | 62.5 | $^\circ\text{C/W}$ |

N-Channel Electrical Characteristics

| Symbol | Parameter | Condition | Min | Typ | Max | Unit |
|--|--|---|-----|------|------|------|
| Static Electrical Characteristics @ T_J = 25°C (unless otherwise stated) | | | | | | |
| V _{(BR)DSS} | Drain-Source Breakdown Voltage | V _{GS} =0V, I _D =250μA | 30 | -- | -- | V |
| I _{DSS} | Zero Gate Voltage Drain Current(T _A =25°C) | V _{DS} =30V,V _{GS} =0V | -- | -- | 1 | μA |
| | Zero Gate Voltage Drain Current(T _A =125°C) | V _{DS} =30V,V _{GS} =0V | -- | -- | 100 | μA |
| I _{GSS} | Gate-Body Leakage Current | V _{GS} =±20V,V _{DS} =0V | -- | -- | ±100 | nA |
| V _{GS(TH)} | Gate Threshold Voltage | V _{DS} =V _{GS} ,I _D =250μA | 1.3 | 1.9 | 2.4 | V |
| R _{DS(ON)} | Drain-Source On-State Resistance ③ | V _{GS} =10V, I _D =8A | -- | 15 | 19 | mΩ |
| | | V _{GS} =4.5V, I _D =4A | -- | 23 | 29 | mΩ |
| Dynamic Electrical Characteristics @ T_J = 25°C (unless otherwise stated) | | | | | | |
| C _{iss} | Input Capacitance | V _{DS} =15V,V _{GS} =0V, f=1MHz | 350 | 460 | 550 | pF |
| C _{oss} | Output Capacitance | | 75 | 130 | pF | |
| C _{rss} | Reverse Transfer Capacitance | | 60 | 110 | pF | |
| R _g | Gate Resistance | f=1MHz | -- | 4.8 | -- | Ω |
| Q _g | Total Gate Charge | V _{DS} =15V,I _D =8A, V _{GS} =10V | -- | 11.3 | -- | nC |
| Q _{gs} | Gate Source Charge | | -- | 3 | -- | nC |
| Q _{gd} | Gate Drain Charge | | -- | 4.3 | -- | nC |
| Switching Characteristics | | | | | | |
| t _{d(on)} | Turn on Delay Time | V _{DD} =15V, I _D =8A, R _G =3Ω, V _{GS} =10V | -- | 7 | -- | nS |
| t _r | Turn on Rise Time | | -- | 10 | -- | nS |
| t _{d(off)} | Turn Off Delay Time | | - | 22 | -- | nS |
| t _f | Turn Off Fall Time | | -- | 7 | -- | nS |
| Source Drain Diode Characteristics | | | | | | |
| V _{SD} | Forward on voltage | I _{SD} =8A,V _{GS} =0V | -- | 0.9 | 1.2 | V |
| t _{rr} | Reverse Recovery Time | T _J =25°C,I _{sd} =8A, V _{GS} =0V | -- | 9.5 | -- | nS |
| Q _{rr} | Reverse Recovery Charge | di/dt=500A/μs | -- | 11.8 | -- | nC |

NOTE:

- ① Repetitive rating; pulse width limited by max. junction temperature.
- ② Limited by T_{Jmax}, starting T_J = 25°C, L = 0.5mH,R_G = 25Ω, I_{AS} = 6A, V_{GS} =10V. Part not recommended for use above this value
- ③ Pulse width ≤ 300μs; duty cycle≤ 2%.

P-Channel Electrical Characteristics

| Symbol | Parameter | Condition | Min | Typ | Max | Unit |
|--|--|--|------|------|------|------|
| Static Electrical Characteristics @ T_J = 25°C (unless otherwise stated) | | | | | | |
| V _{(BR)DSS} | Drain-Source Breakdown Voltage | V _{GS} =0V, I _D =-250μA | -30 | -- | -- | V |
| I _{DSS} | Zero Gate Voltage Drain Current(T _A =25°C) | V _{DS} =-30V, V _{GS} =0V | -- | -- | -1 | μA |
| | Zero Gate Voltage Drain Current(T _A =125°C) | V _{DS} =-30V, V _{GS} =0V | -- | -- | -100 | μA |
| I _{GSS} | Gate-Body Leakage Current | V _{GS} =±20V, V _{DS} =0V | -- | -- | ±100 | nA |
| V _{GS(TH)} | Gate Threshold Voltage | V _{DS} =V _{GS} , I _D =-250μA | -1.3 | -1.9 | -2.4 | V |
| R _{DS(ON)} | Drain-Source On-State Resistance ③ | V _{GS} =-10V, I _D =-8A | -- | 23 | 29 | mΩ |
| | | V _{GS} =-4.5V, I _D =-4A | -- | 38 | 47 | mΩ |
| Dynamic Electrical Characteristics @ T_J = 25°C (unless otherwise stated) | | | | | | |
| C _{iss} | Input Capacitance | V _{DS} =-15V, V _{GS} =0V, f=1MHz | 760 | 860 | 960 | pF |
| C _{oss} | Output Capacitance | | 60 | 140 | 200 | pF |
| C _{rss} | Reverse Transfer Capacitance | | 30 | 95 | 150 | pF |
| R _g | Gate Resistance | f=1MHz | -- | 10.6 | -- | Ω |
| Q _g | Total Gate Charge | V _{DS} =-15V, I _D =-8A, V _{GS} =-10V | -- | 19 | -- | nC |
| Q _{gs} | Gate Source Charge | | -- | 4.3 | -- | nC |
| Q _{gd} | Gate Drain Charge | | -- | 6.5 | -- | nC |
| Switching Characteristics | | | | | | |
| t _{d(on)} | Turn on Delay Time | V _{DD} =-15V, I _D =-8A, R _G =3Ω, V _{GS} =-10V | -- | 6 | -- | ns |
| t _r | Turn on Rise Time | | -- | 5 | -- | ns |
| t _{d(off)} | Turn Off Delay Time | | - | 25 | -- | ns |
| t _f | Turn Off Fall Time | | -- | 7 | -- | ns |
| Source Drain Diode Characteristics | | | | | | |
| V _{SD} | Forward on voltage | I _{SD} =-8A, V _{GS} =0V | -- | -0.9 | -1.2 | V |
| t _{rr} | Reverse Recovery Time | T _J =25°C, I _{sd} =-8A, V _{GS} =0V | -- | 7 | -- | nS |
| Q _{rr} | Reverse Recovery Charge | di/dt=-500A/μs | -- | 6.3 | -- | nC |

NOTE:

- ① Repetitive rating; pulse width limited by max. junction temperature.
- ② Limited by T_{Jmax}, starting T_J = 25°C, L = 0.5mH, R_G = 25Ω, I_{AS} = -9A, V_{GS} = -10V. Part not recommended for use above this value
- ③ Pulse width ≤ 300μs; duty cycle ≤ 2%.

N-Channel Typical Characteristics

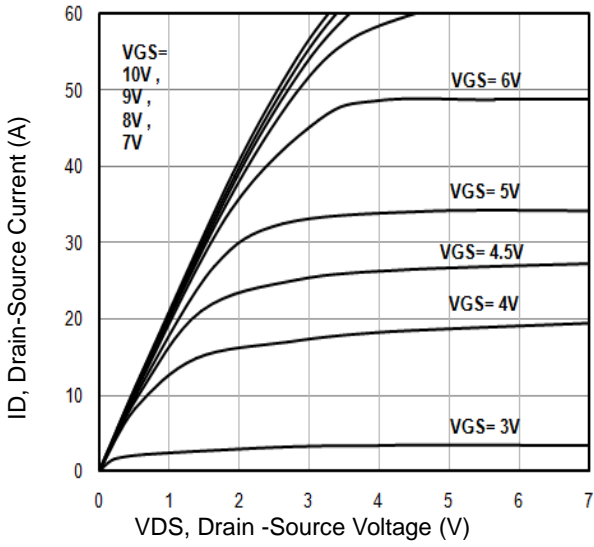

Fig1. Typical Output Characteristics

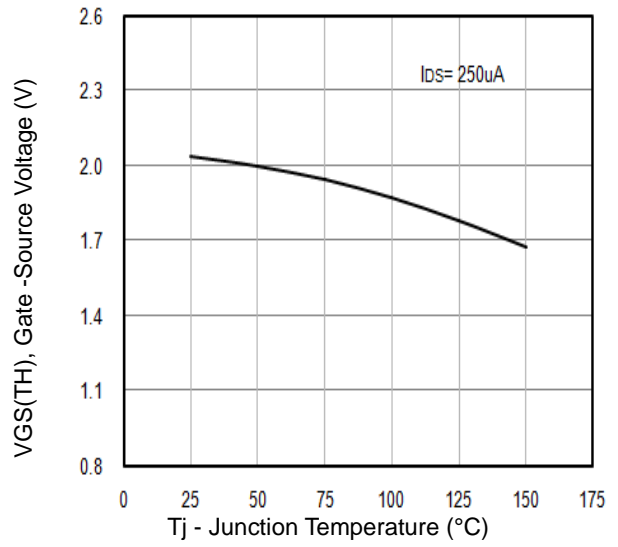

Fig2. $V_{GS(TH)}$ Gate-Source Voltage Vs. T_j

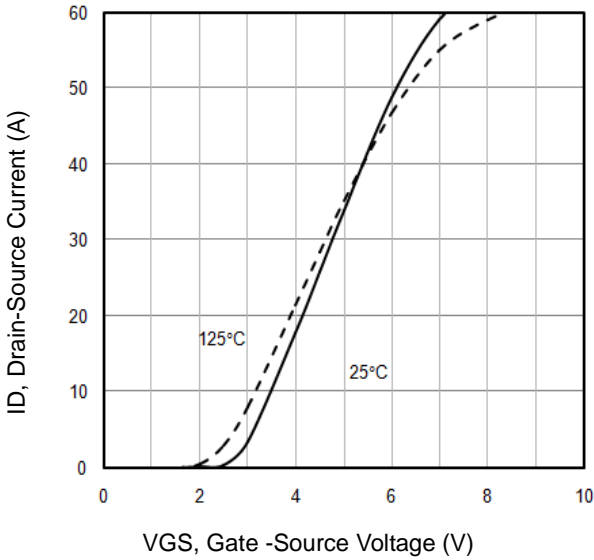

Fig3. Typical Transfer Characteristics

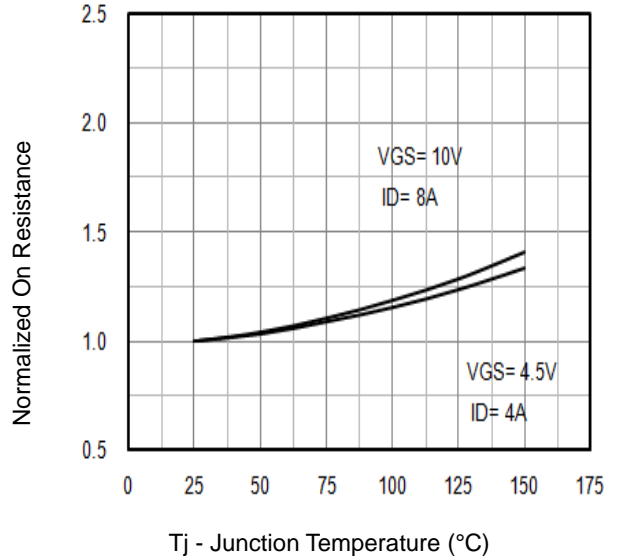

Fig4. Normalized On-Resistance Vs. T_j

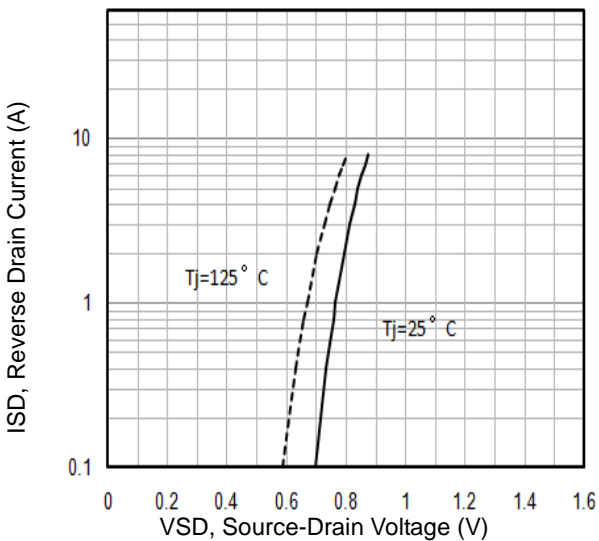

Fig5. Typical Source-Drain Diode Forward Voltage

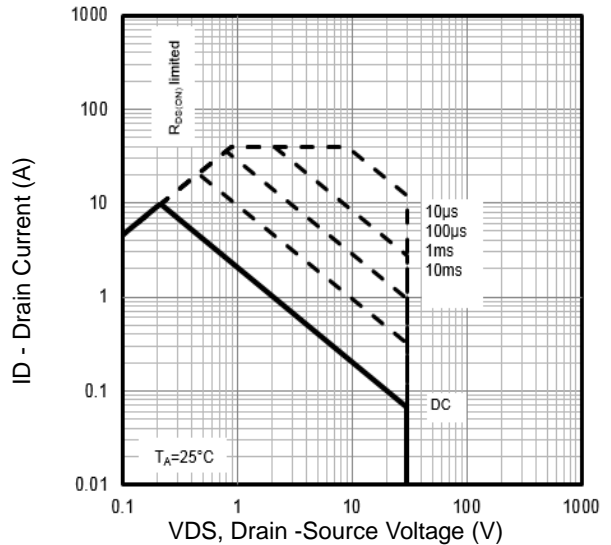

Fig6. Maximum Safe Operating Area

N-Channel Typical Characteristics

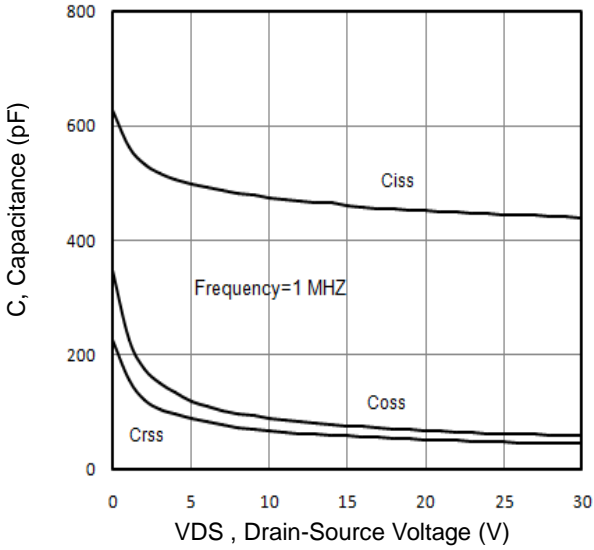

Fig7. Typical Capacitance Vs. Drain-Source Voltage

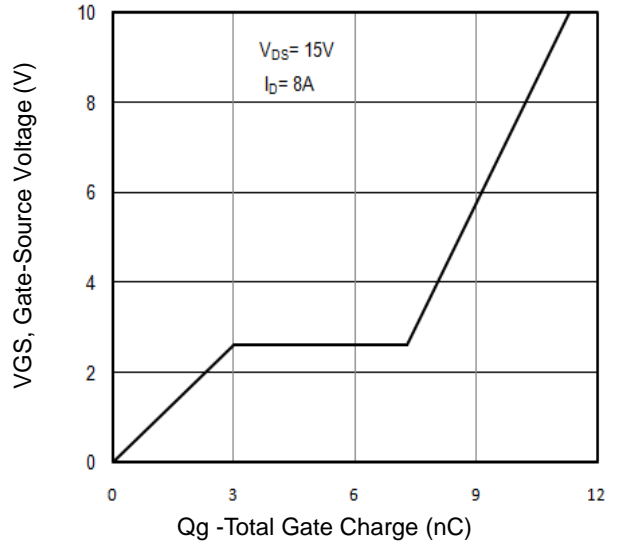

Fig8. Typical Gate Charge Vs. Gate-Source Voltage

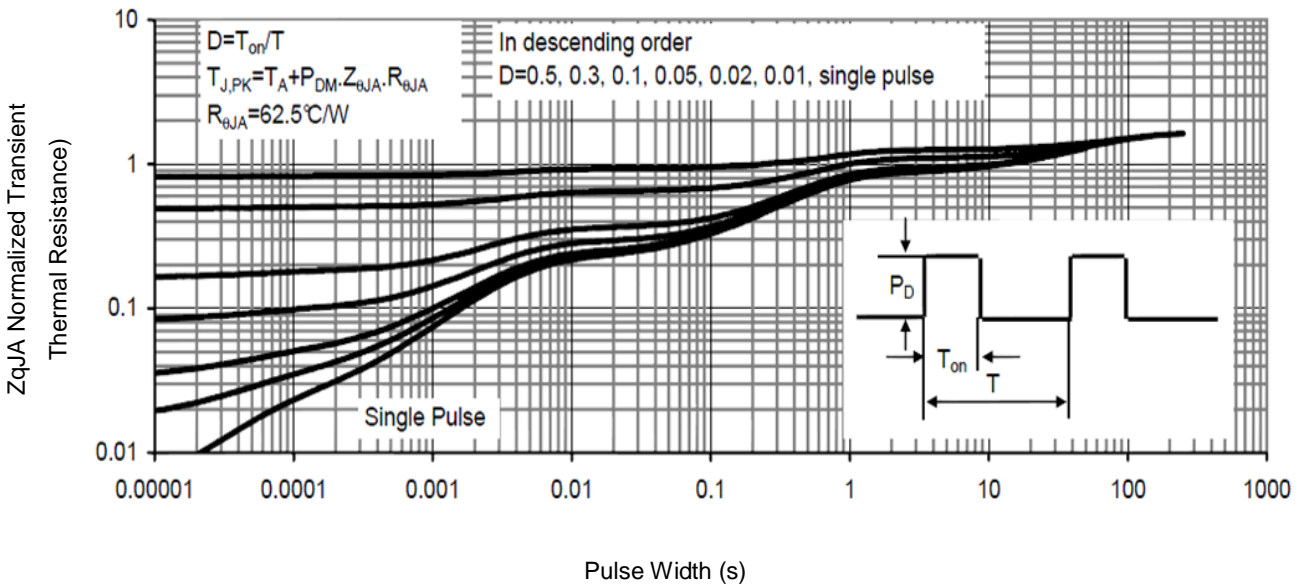

Fig 9 .Normalized Maximum Transient Thermal Impedance

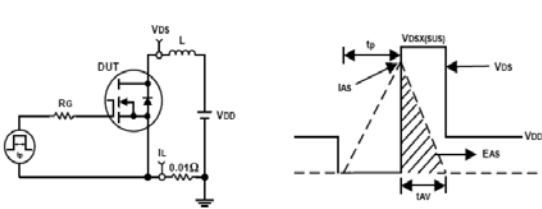

Fig10. Unclamped Inductive Test Circuit and waveforms

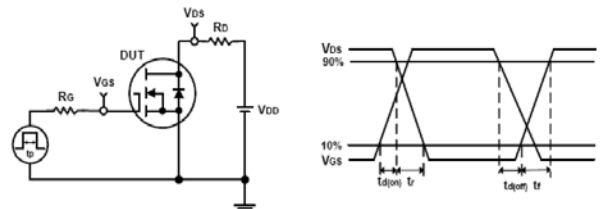

Fig11. Switching Time Test Circuit and waveforms

P-Channel Typical Characteristics

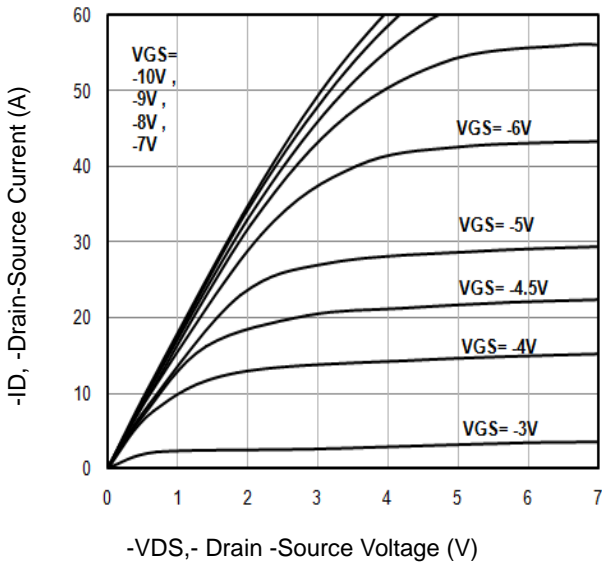

Fig1. Typical Output Characteristics

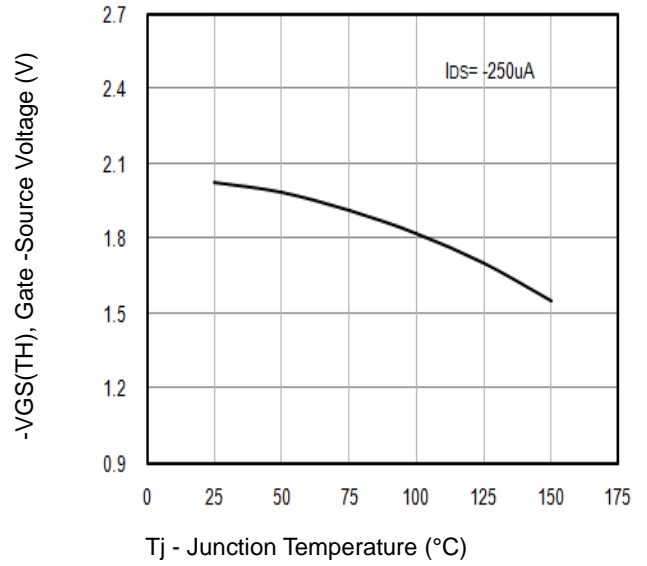

Fig2. -VGS(TH) Gate -Source Voltage Vs. Tj

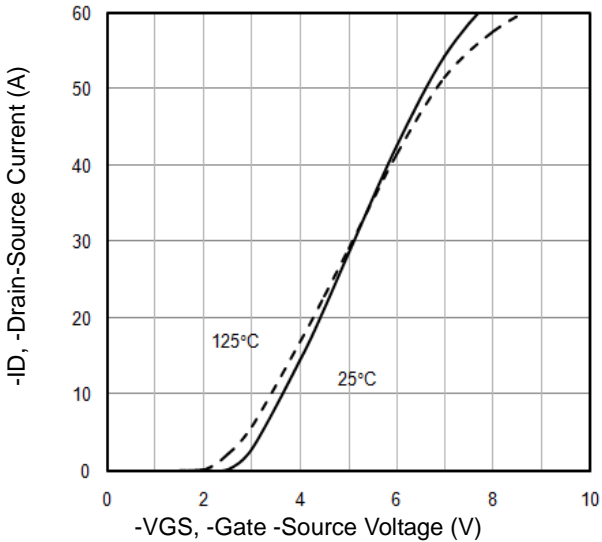

Fig3. Typical Transfer Characteristics

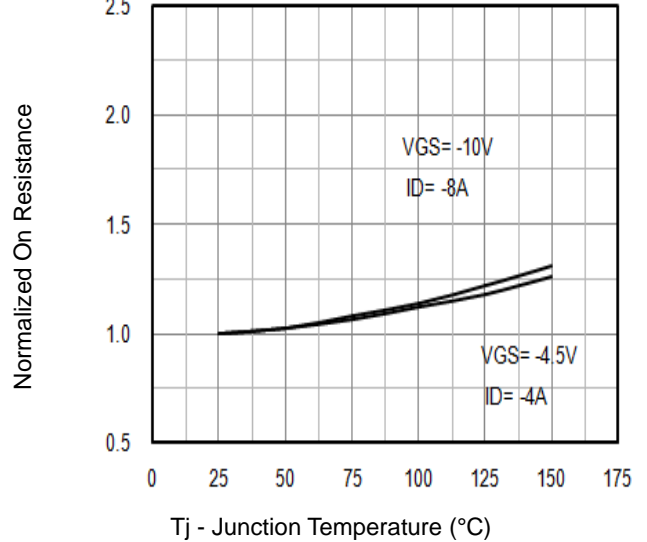

Fig4. Normalized On-Resistance Vs. Tj

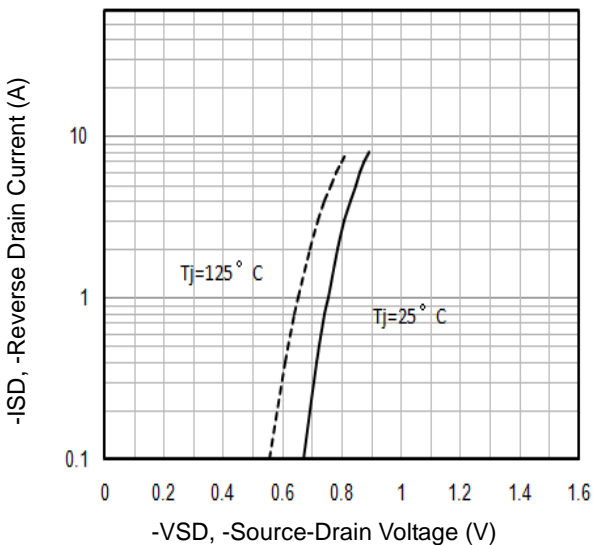

Fig5. Typical Source-Drain Diode Forward Voltage

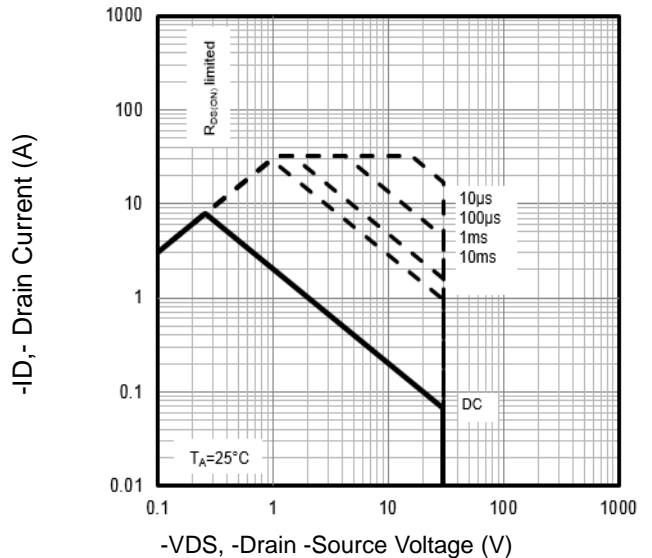

Fig6. Maximum Safe Operating Area

P-Channel Typical Characteristics

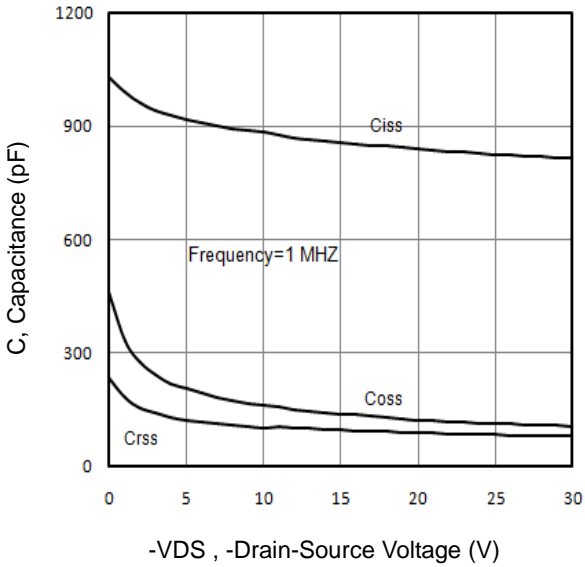

Fig7. Typical Capacitance Vs.Drain-Source Voltage

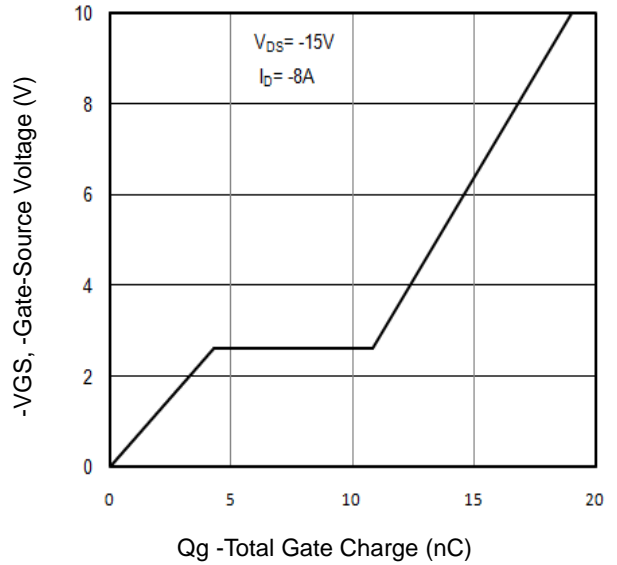

Fig8. Typical Gate Charge Vs.Gate-Source Voltage

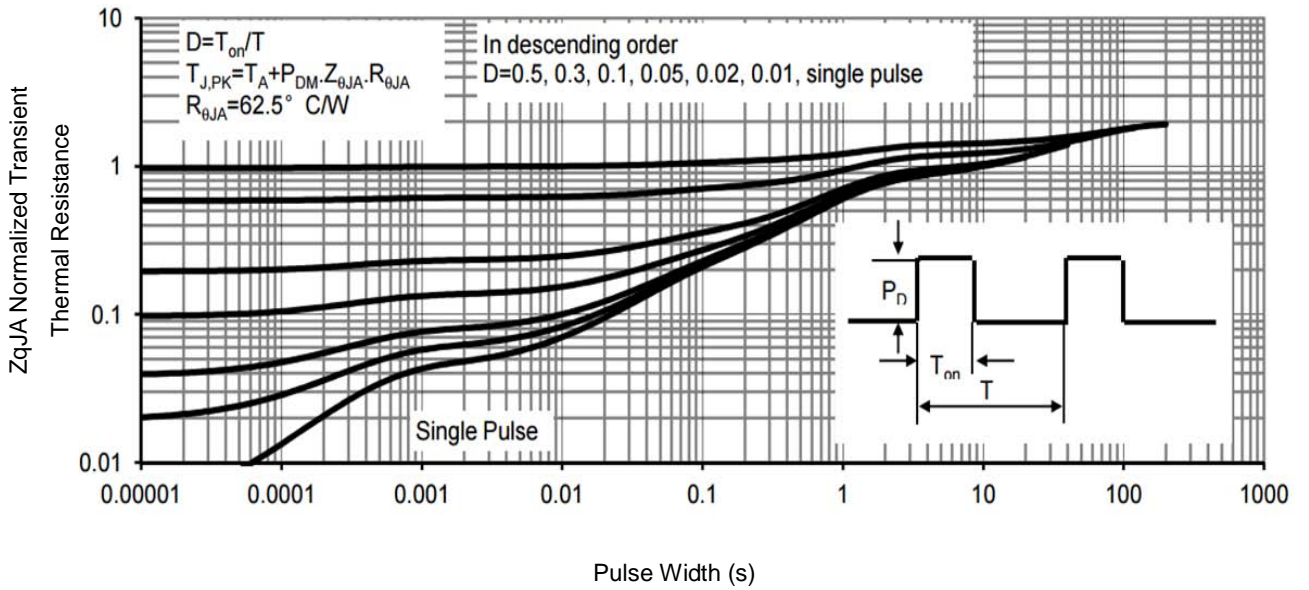

Fig9. Normalized Maximum Transient Thermal Impedance

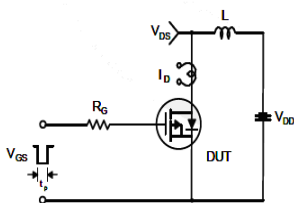

Fig10. Unclamped Inductive Test Circuit and Waveforms

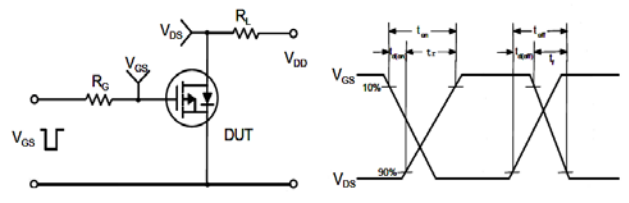
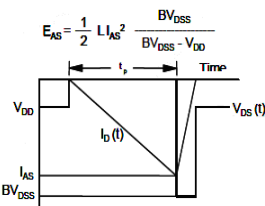
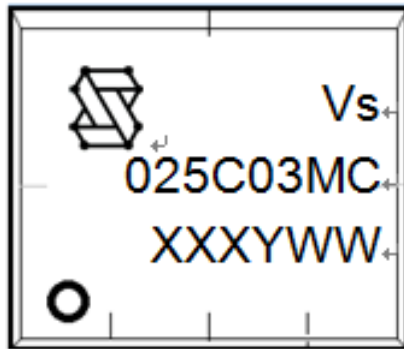

Fig11. Switching Time Test Circuit and waveforms

Marking Information



1st line: Company Code (Vs), Company Logo

2nd line: Part Number (025C03MC)

3rd line: Date code (XXXYWW)

LOT: Wafer Lot Number

Y: Year Code, e.g. E means 2017

WW: Week Code

SOP8 Package Outline Data

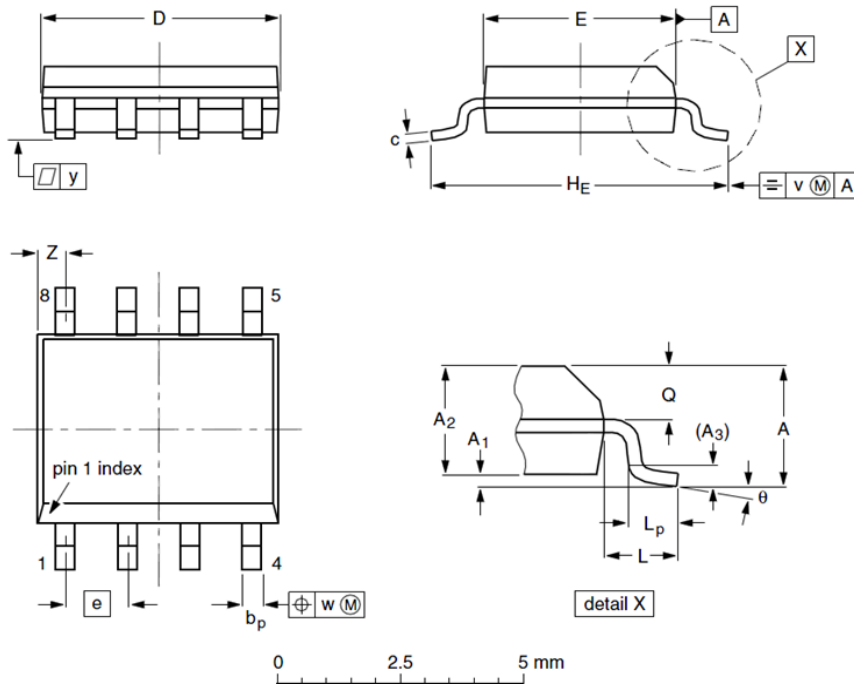

| Label | Dimensions (unit: mm) | | |
|----------------|-----------------------|------|-------|
| | Min | Typ | Max |
| A | -- | -- | 1.75 |
| A ₁ | 0.10 | 0.18 | 0.25 |
| A ₂ | 1.25 | 1.35 | 1.50 |
| A ₃ | -- | 0.25 | -- |
| b _p | 0.36 | 0.42 | 0.51 |
| c | 0.19 | 0.22 | 0.25 |
| D | 4.80 | 4.92 | 5.00 |
| E | 3.80 | 3.90 | 4.00 |
| e | -- | 1.27 | -- |
| H _E | 5.80 | 6.00 | 6.20 |
| L | -- | 1.05 | -- |
| L _p | 0.40 | 0.68 | 1.00 |
| Q | 0.60 | 0.65 | 0.725 |
| v | -- | 0.25 | -- |
| w | -- | 0.25 | -- |
| y | -- | 0.10 | -- |
| Z | 0.30 | 0.50 | 0.70 |
| θ | 0° | | 8° |

Notes:

1. Follow JEDEC MS-012.
2. Dimension "D" does NOT include mold flash, protrusions or gate burrs. Mold flash, protrusions or gate burrs shall not exceed 0.15mm per side.
3. Dimension "E" does NOT include interlead flash or protrusion. Interlead flash or protrusion shall not exceed 0.25mm per side.
4. Dimension "b_p" does NOT include dambar protrusion. Allowable dambar protrusion shall be 0.1mm total in excess of "b_p" dimension at maximum material condition. The dambar cannot be located on the lower radius of the foot.

Customer Service

Sales and Service:

sales@vgsemi.com

Vanguard Semiconductor CO., LTD

TEL: (86-755) -26902410

FAX: (86-755) -26907027

WEB: www.vgsemi.com

X-ON Electronics

Largest Supplier of Electrical and Electronic Components

Click to view similar products for [MOSFET](#) category:

Click to view products by [Vanguard](#) manufacturer:

Other Similar products are found below :

[614233C](#) [648584F](#) [MCH3443-TL-E](#) [MCH6422-TL-E](#) [FDPF9N50NZ](#) [FW216A-TL-2W](#) [FW231A-TL-E](#) [APT5010JVR](#) [NTNS3A92PZT5G](#)
[IRF100S201](#) [JANTX2N5237](#) [2SK2464-TL-E](#) [2SK3818-DL-E](#) [FCA20N60_F109](#) [FDZ595PZ](#) [STD6600NT4G](#) [FSS804-TL-E](#) [2SJ277-DL-E](#)
[2SK1691-DL-E](#) [2SK2545\(Q,T\)](#) [D2294UK](#) [405094E](#) [423220D](#) [MCH6646-TL-E](#) [TPCC8103,L1Q\(CM](#) [367-8430-0972-503](#) [VN1206L](#)
[424134F](#) [026935X](#) [051075F](#) [SBVS138LT1G](#) [614234A](#) [715780A](#) [NTNS3166NZT5G](#) [751625C](#) [873612G](#) [IRF7380TRHR](#)
[IPS70R2K0CEAKMA1](#) [RJK60S3DPP-E0#T2](#) [RJK60S5DPK-M0#T0](#) [APT5010JVFR](#) [APT12031JFLL](#) [APT12040JVR](#) [DMN3404LQ-7](#)
[NTE6400](#) [JANTX2N6796U](#) [JANTX2N6784U](#) [JANTXV2N5416U4](#) [SQM110N05-06L-GE3](#) [SIHF35N60E-GE3](#)