

Helping Customers Innovate, Improve & Grow



PX-700

Features

- 5X7mm Surface Mount Package
- Frequency Range: 1 MHz to 800 MHz
- AC MOS, TTL, LVPECL and LVDS
- Wide operating temperature range -55°C to +125°C
- MIL-PRF-55310 Class B Screening (optional)
- Reflow Process Compatible
- Fully RoHS compliant *
- ECCN: EAR99
- COO: USA
- Previous Model: C1250

* (Except parts with Sn-Pb Solder Coated Option)



Applications

- Military Systems
- Avionics and Instrumentation
- Test Equipment
- Medical Equipment

Performance Specifications

Frequency Stabilities ¹					
Parameter	Min	Typ	Max	Units	Condition
vs. operating temperature range (Referenced to +25°C)	-15 -25 -50 -65 -80 -100		+15 +25 +50 +65 +80 +100	ppm ppm ppm ppm ppm ppm	(See Table I under ordering information)
Initial tolerance	-15 -25 -50 -65 -80 -100		+15 +25 +50 +65 +80 +100	ppm ppm ppm ppm ppm ppm	@+25°C
Overall tolerance (Referenced to +25°C) (Included operation temperature and initial accuracy)	-25 -50 -65 -80 -100		+25 +50 +65 +80 +100	ppm ppm ppm ppm ppm	(See Table II under ordering information)
vs. supply voltage change vs. load change vs. aging / 1 year vs. aging / year (following years)	-2 -1 -3 -1		+2 +1 +3 +1	ppm ppm ppm ppm	VS ± 5% Load ± 5% after 30 days of operation

Performance Specifications

Supply Voltage (Vs)					
Parameter	Min	Typ	Max	units	Condition
Supply voltage	4.75	5.0	5.25	VDC	
Supply voltage	3.135	3.3	3.465	VDC	
Supply voltage	2.375	2.5	2.625	VDC	
Current consumption * No load (+5 VDC)			15 20 40	mA mA mA	ACMOS or TTL 1.0 to 23.9 MHz ACMOS or TTL 24 to 49.9 MHz ACMOS or TTL 50 to 125.00 MHz
Current consumption * No load (+3.3 VDC or +2.5 VDC)			6 8 16 20 40 75 100	mA mA mA mA mA mA mA	ACMOS 1.0 to 14.9 MHz ACMOS 15.0 to 39.9 MHz ACMOS 40.0 to 59.9 MHz ACMOS 60.0 to 84.9 MHz ACMOS 85.0 to 125.0 MHz LVPECL or LVDS <200 MHz LVPECL or LVDS >200 MHz
Current consumption * No load (+1.8 VDC)			1.5 2.0 8.0	mA mA mA	ACMOS 1.0 to 14.9 MHz ACMOS 15.0 to 49.9 MHz ACMOS 50.0 to 100 MHz

RF Output					
Parameter	Min	Typ	Max	Units	Condition
Signal	ACMOS				
Load		15		pF	
Signal Level (Vol)			0.5 0.3 0.25	VDC VDC VDC	with Vs=5.0V and 15pF load with Vs=3.3V and 15pF load with Vs= 2.5V and 15pF load
Signal Level (Voh)	4.5 3.0 2.25			VDC VDC VDC	with Vs=5.0V and 15pF load with Vs=3.3V and 15pF load with Vs=2.5V and 15pF load
Rise and fall times for ACMOS (measured 10% to 90%)			10 6 3	ns ns ns	1.0 to 23.9 MHz 24.0 to 79.9 MHz 80.0 to 125.0 MHz
Duty cycle	45 40		55 60	% %	@ 50% Vs< 15 MHz @ 50% Vs=> 15 MHz
Signal	TTL				
Load			10	TTL	Freq < 60MHz , 6 TTL > 60 MHz
Signal Level (Vol)			0.4	V	
Signal Level (Voh)	+2.4			V	
Rise and fall times for ACMOS (measured 20% to 80%)			15 5	ns ns	@ (0.5-2.4V), <= 20MHz @ (0.5-2.4V, > 20 MHz)
Duty cycle	45 40		55 60	% %	@ +1.5V, < 4 MHz @ +1.5V, >= 4 MHz
Signal	LVPECL				
Load			50	ohm	into Vcc-2V or Thevenin Equivalent
Signal Level (Vol)			Vs -1.62	VDC	-40....+85°C operating temp
Signal Level (Voh)	Vs- 1.025			VDC	-40....+85°C operating temp
Rise and fall times for ACMOS (measured 20% to 80%)			1000 600	ps ps	< 100 MHz >= 100 MHz
Duty Cycle	45		55	%	@ 50% Vdd
Jitter (rms)			10 0.5	ps ps	BW = 10Hz to 20 MHz BW = 12KHz to 20 MHz
Period Jitter (pk-pk)			40	ps	10,000 Samples - Rising edge

Parameter	Min	Typ	Max	Units	Condition
Signal	LVDS				
Load	60	100	140	ohm	Between outputs
Signal Level (Vol)		1.2		VDC	
Signal Level (Voh)		1.4		VDC	
Differential Voltage (Vod)	240	330	460	mVpeak	
Common Mode (Offset) Voltage (Vos)	1.125	1.2	1.375	V	
Start-up Time			10	ms	
Rise \ Fall Time		600	1000	ps	measured @ 20% to 80% of Vod
Duty cycle	45		55	%	@ 50% of Vod
Jitter (rms)			5 1	ps ps	BW = 10Hz to 20 MHz BW = 12KHz to 20 MHz
Period Jitter (pk-pk)			40	ps	10,000 Samples - Rising edge
Absolute Maximum Ratings					
Supply voltage (Vs)			7.0	V	with Vs=5.0VDC and 3.3 VDC
Operable temperature range	-55		+125	°C	
Storage temperature range	-62		+125	°C	

Additional Parameters		
Screening	Vectron Verification	
	Class B, MIL-PRF-55310, Rev.E	
Output Enable	Logic "0" input = Outputs disabled (Tri-state) Logic "1" or floating input = Outputs enabled	
	Logic "0" or floating input = Outputs enabled Logic "1" input = Outputs disabled (Tri-state)	
Weight	< 2 grams	
Processing & Packing	Handling & processing note	

Standard Environmentals	
Vibration	MIL-STD-202, Method 204, Condition G (30 G, 10Hz-2000Hz)
Shock	MIL-STD-202, Method 213, Condition I (100 G, 6ms, Sawtooth)
Acceleration	MIL-STD-883, Method 2001, Condition A (5000 G, Y1 Plane)
Temperature Cycling	MIL-STD-883, Method 1010, Condition B
Thermal Shock	MIL-STD-202, Method 107, Condition B
Solderability	MIL-STD-202, Method 208
Leak Test (Fine and Gross)	MIL-STD-883, Method 1014, Condition A1 and C1

Outline Drawing / Enclosure

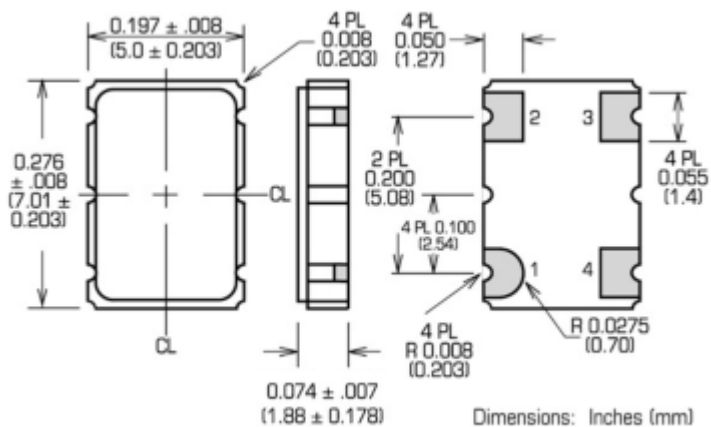

Type LCC (ACMOS or TTL)

Package Code	Height "H"
0	1.88mm

Pin Connections

1	Enable/Disable or N/C
2	Ground (Case)
3	Output
4	Supply

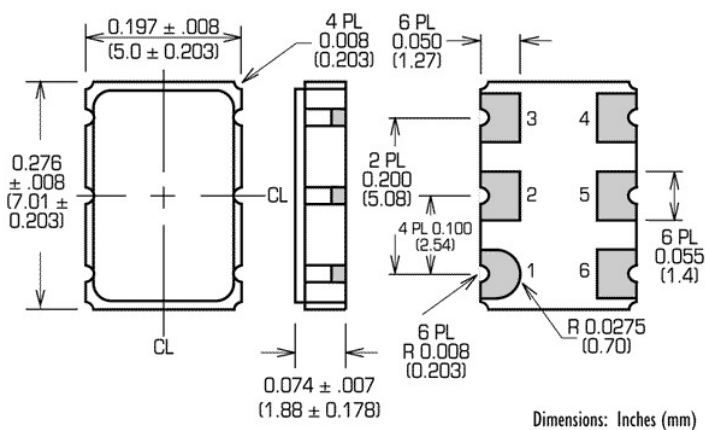

Type LCC (LVPECL or LVDS)

Package Code	Height "H"
1	1.88mm

Pin Connections

1	Enable/Disable or N/C
2	Enable/Disable or N/C (custom number required)
3	Ground (Case)
4	Output
5	Complementary Output
6	Supply

Outline Drawing / Enclosure

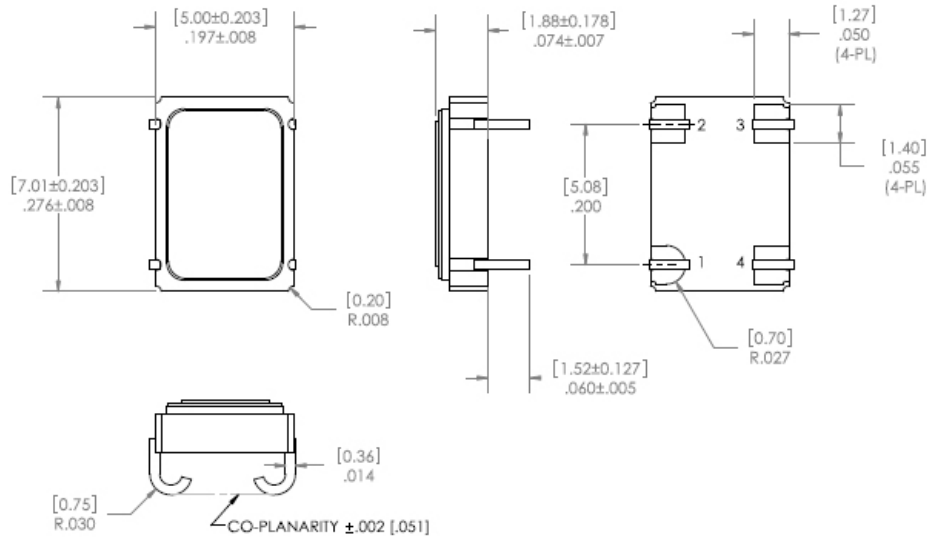

J-Leads are tinned with Alpha Sn/Pb 63/37 solder.

Type J-Leads (ACMOS or TTL)	
Package Code	Height "H"
2	3.40 mm

Pin Connections	
1	Enable/Disable or N/C
2	Ground (Case)
3	RF Output
4	Supply Voltage

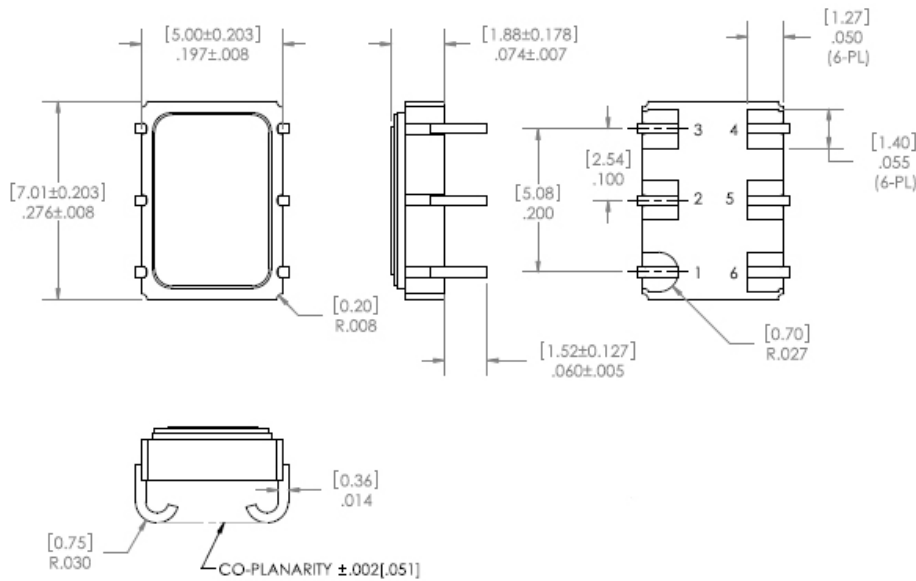

J-Leads are tinned with Alpha Sn/Pb 63/37 solder.

Type J-Leads (LVPECL or LVDS)	
Package Code	Height "H"
3	3.40 mm

Pin Connections	
1	Enable/Disable or N/C
2	N/C
3	Ground (Case)
4	RF Output
5	Complementary Output
6	Supply Voltage

Recommended Reflow Profiles for Pb-Free & Sn-Pb

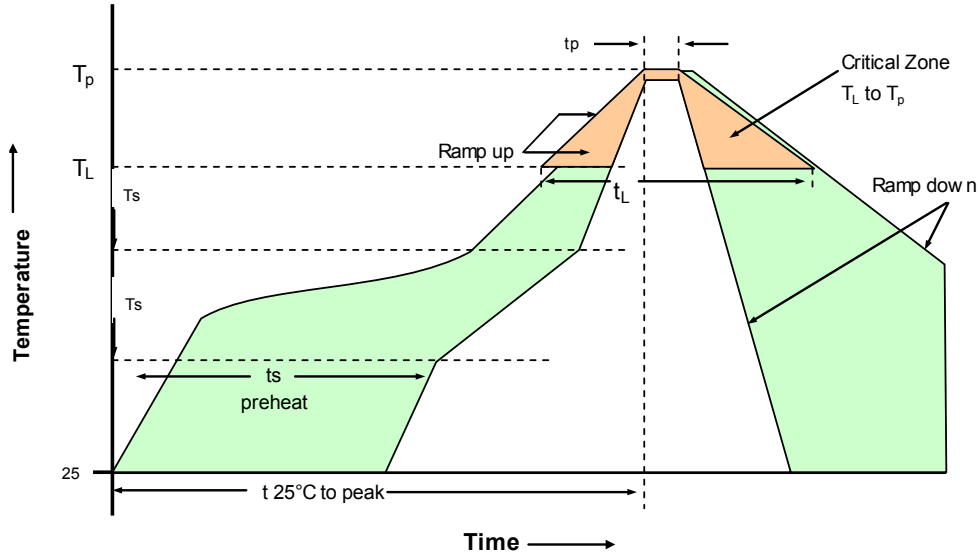

230°C Reflow Profile

Profile Feature	Sn-Pb Assembly	Profile Feature	Sn-Pb Assembly
Average ramp-up rate (TL to TP)	3°C/second max.	Time 25°C to Peak Temperature	4 minutes max.
Preheat - Temperature min T_{smin}	135°C	Time maintained above	
- Temperature Min T_{smax}	155°C	- Temperature (TL)	183°C
- Time (min to max) (ts)	60-90 seconds	- Time (tL)	45-60 seconds
T_{smax} to TL -Ramp-up Rate	3°C/second max.		
Time maintained above - Temperature (TL)	183°C	Time within 5°C of actual	10-20 seconds max.
- Time (TL)	40-60 seconds	Peak Temperature (tp)	
Peak Temperature (Tp)	max 230°C	Ramp-down Rate	6°C/second max.

Note: All temperatures refer to topside of the package, measured on the package body surface.

260°C Reflow Profile

Profile Feature	Pb-Free Assembly	Profile Feature	Pb-Free Assembly
Average ramp-up rate (TL to TP)	3°C/second max.	Time 25°C to Peak Temperature	8 minutes max.
Preheat - Temperature min T_{smin}	150°C	Time maintained above	
- Temperature min T_{smax}	200°C	- Temperature (TL)	217°C
- Time (min to max) (ts)	60-180 seconds	- Time (tL)	60-150 seconds
T_{smax} to TL -Ramp-up Rate	3°C/second max.		
Time maintained above - Temperature (TL)	217°C	Time within 5°C of actual	20-40 seconds max.
- Time (TL)	60-150 seconds	Peak Temperature (tp)	
Peak Temperature (Tp)	max 260°C	Ramp-down Rate	6°C/second max.

Note: All temperatures refer to topside of the package, measured on the package body surface.

Ordering Information

PX - 700 0 - D A T - F K X B - 10M000000

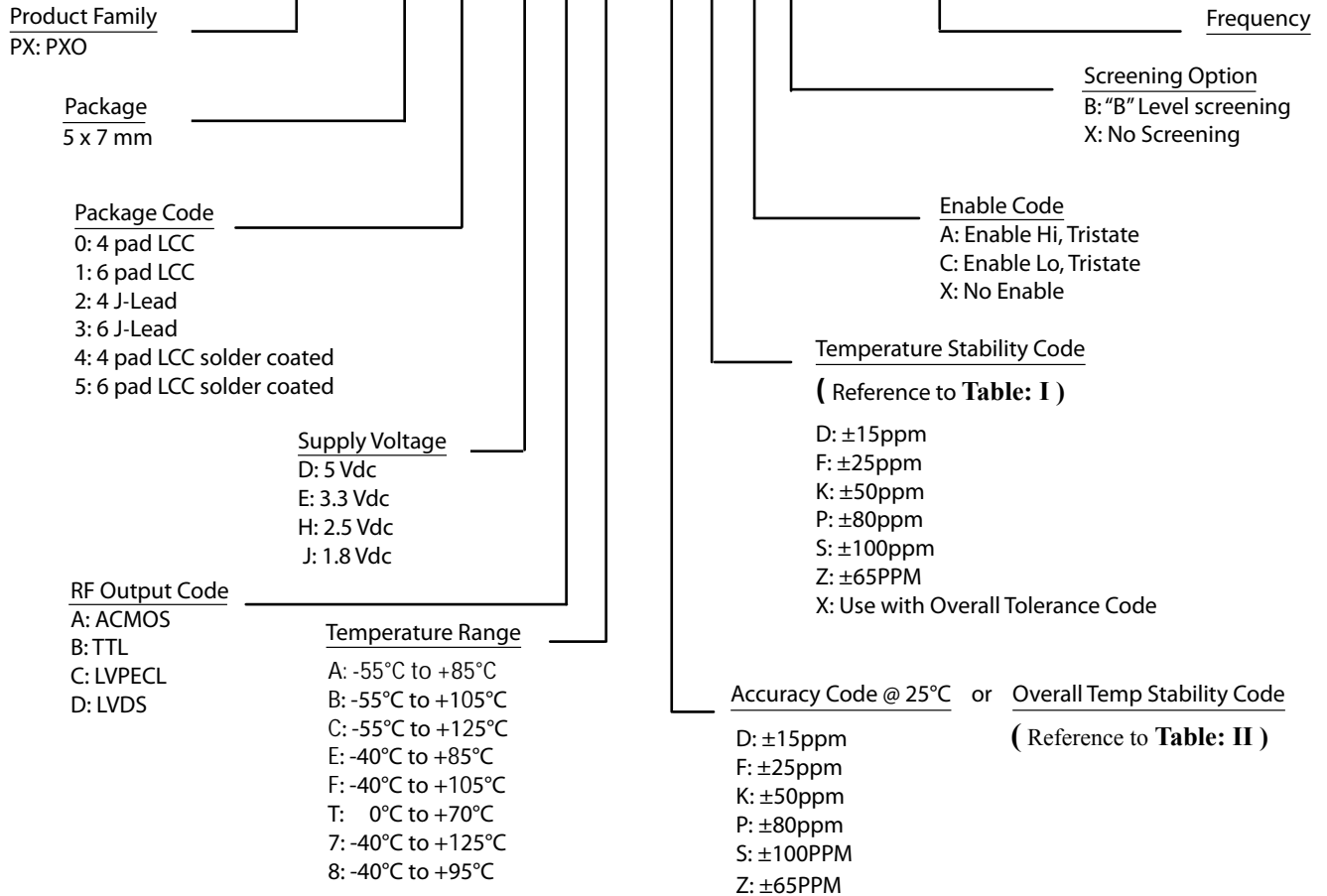

Available Temperature Stability Code	
Temp Range	Temp Stability
B: -55°C to +105°C C: -55°C to +125°C F: -40°C to +105°C 7: -40°C to +125°C	K: ± 50ppm
	Z ± 65ppm
	P ± 80ppm
	S ± 100ppm
A: -55°C to +85°C E: -40°C to +85°C 8: -40°C to +95°C	F: ± 25ppm
	K: ± 50ppm
	Z ± 65ppm
	P ± 80ppm
T: 0°C to +70°C	S ± 100ppm
	D: ± 15ppm
	F: ± 25ppm
	K: ± 50ppm
	Z ± 65ppm
	P ± 80ppm
	S ± 100ppm

Table: I

Available Overall Tolerance Code		
Temp Range	Overall Tolerance	Temp Stability
B: -55°C to +105°C C: -55°C to +125°C F: -40°C to +105°C 7: -40°C to +125°C	Z: ± 65ppm	X
	P: ± 80ppm	X
	S: ± 100ppm	X
A: -55°C to +85°C E: -40°C to +85°C 8: -40°C to +95°C	K: ± 50ppm	X
	Z: ± 65ppm	X
	P: ± 80ppm	X
	S: ± 100ppm	X
T: 0°C to +70°C	F: ± 25ppm	X
	K: ± 50ppm	X
	Z: ± 65ppm	X
	P: ± 80ppm	X
	S: ± 100ppm	X

Table: II

This page is purposely left blank

Notes:

1. Contact factory for improved stabilities or additional product options. **Not all options and codes are available at all frequencies or operating temperature ranges: reference table on page 1.**
2. Unless other stated all values are valid after warm-up time and refer to typical conditions for supply voltage, frequency control voltage, load, temperature (25°C).
3. Subject to technical modification.
4. Contact factory for availability.
5. **Enable Codes: Option A is standard for AC MOS, TTL and LVDS; Option C is standard for LVPECL. Contact factory for**

For Additional Information, Please Contact

USA:

Vectron International
267 Lowell Road, Unit 102
Hudson, NH 03051
Tel: 1.888.328.7661
Fax: 1.888.329.8328

Europe:

Vectron International
Landstrasse, D-74924
Neckarbischofsheim, Germany
Tel: +49 (0) 3328.4784.17
Fax: +49 (0) 3328.4784.30

Asia:

Vectron International
68 Yin Cheng Road(C), 22nd Floor
One LuJiaZui
Pudong, Shanghai 200120, China
Tel: 86.21.6194.6886
Fax: 86.21.6194.6699

Disclaimer

Vectron International reserves the right to make changes to the product(s) and or information contained herein without notice. No liability is assumed as a result of their use or application. No rights under any patent accompany the sale of any such product(s) or information.

X-ON Electronics

Largest Supplier of Electrical and Electronic Components

Click to view similar products for [Standard Clock Oscillators](#) category:

Click to view products by [Vectron](#) manufacturer:

Other Similar products are found below :

[601252](#) [F335-12](#) [F335-25](#) [F535L-33.333](#) [F535L-50](#) [ASV-20.000MHZ-LR-T](#) [ECS-2018-160-BN-TR](#) [EL13C7-H2F-125.00M](#) [MXO45HS-2C-66.6666MHZ](#) [SiT8209AI-32-33E-125.000000](#) [SM4420TEV-40.0M-T1K](#) [F335-24](#) [F335-40](#) [F535L-10](#) [F535L-12](#) [F535L-16](#) [F535L-24](#) [F535L-27](#) [F535L-48](#) [PE7744DW-100.0M](#) [CSX-750FCC14745600T](#) [ASF1-3.686MHZ-N-K-S](#) [XO57CTECNA3M6864](#) [ECS-2100A-147.4](#) [601251](#) [EP16E7E2H26.000MTR](#) [SIT8918AA-11-33S-16.000000G](#) [XO3003](#) [9120AC-2D2-33E212.500000](#) [9102AI-243N25E100.00000](#) [8208AC-82-18E-25.00000](#) [ASDK2-32.768KHZ-LR-T3](#) [8008AI-72-XXE-24.545454E](#) [8004AC-13-33E-133.33000X](#) [AS-4.9152-16-SMD-TR](#) [ASFL1-48.000MHZ-LC-T](#) [SIT8920AM-31-33E-25.0000](#) [DSC1028DI2-019.2000](#) [9121AC-2C3-25E100.00000](#) [9102AI-233N33E100.00000X](#) [9102AI-233N25E200.00000](#) [9102AI-232H25S125.00000](#) [9102AI-133N25E200.00000](#) [9102AC-283N25E200.00000](#) [9001AC-33-33E1-30.000](#) [XLH536125.000JS4I](#) [3921AI-2CF-33NZ125.000000](#) [5730-1SF](#) [PXA000010](#) [SIT1602BC-83-33E-10.000000Y](#)