

Total solder points: 74
Difficulty level: beginner 2 3 4 5 advanced



200W DISCRETE POWER AMPLIFIER



K8060

Ideal for active speaker system or subwoofer, guitar amp, home theatre systems, instrument amp, etc.

ILLUSTRATED ASSEMBLY MANUAL

H8060IP-1

Total solder points: 74
Difficulty level: beginner 2 3 4 5 advanced



200W DISCRETE POWER AMPLIFIER



K8060

Ideal for active speaker system or subwoofer, guitar amp, home theatre systems, instrument amp, etc.

ILLUSTRATED ASSEMBLY MANUAL

H8060IP-1

Specifications:

- ☑ Excellent value for money
- ☑ Full discrete design using Epitaxial Darlington transistors
- ☑ DC supply circuit on board with LED indication
- ☑ Ideal for active speaker system or sub woofer, guitar amp, home theatre systems, instruments amp....
- ☑ Comes complete with transistor isolators, spacers and bolts
- ☑ Overload and short circuit protection

Features:

- 200W music power @ 4 ohm load
- 100Wrms power @ 4 ohm load
- 70Wrms power @ 8 ohm load
- Distortion: 0.02% @ 1KHz/10W
- Damping factor: >800
- Frequency response: 3Hz to 200KHz (-3dB)
- Sensitivity: 0.6Vrms
- Signal to noise ratio: 115dB
- Power supply: 2 x 25-30Vac / 100 - 120VA
- PCB dimensions: 107x62mm (aprx.) :
 - Recommended power transformer: 12030
 - Recommended heat-sink: HSVM100 (pre-drilled) or S44/75 (not drilled)



2

Specifications:

- ☑ Excellent value for money
- ☑ Full discrete design using Epitaxial Darlington transistors
- ☑ DC supply circuit on board with LED indication
- ☑ Ideal for active speaker system or sub woofer, guitar amp, home theatre systems, instruments amp....
- ☑ Comes complete with transistor isolators, spacers and bolts
- ☑ Overload and short circuit protection

Features:

- 200W music power @ 4 ohm load
- 100Wrms power @ 4 ohm load
- 70Wrms power @ 8 ohm load
- Distortion: 0.02% @ 1KHz/10W
- Damping factor: >800
- Frequency response: 3Hz to 200KHz (-3dB)
- Sensitivity: 0.6Vrms
- Signal to noise ratio: 115dB
- Power supply: 2 x 25-30Vac / 100 - 120VA
- PCB dimensions: 107x62mm (aprx.) :
 - Recommended power transformer: 12030
 - Recommended heat-sink: HSVM100 (pre-drilled) or S44/75 (not drilled)



2

1. Assembly (Skipping this can lead to troubles !)

Ok, so we have your attention. These hints will help you to make this project successful. Read them carefully.

1.1 Make sure you have the right tools:

- A good quality soldering iron (25-40W) with a small tip.
- Wipe it often on a wet sponge or cloth, to keep it clean; then apply solder to the tip, to give it a wet look. This is called 'thinning' and will protect the tip, and enables you to make good connections. When solder rolls off the tip, it needs cleaning.
- Thin raisin-core solder. Do not use any flux or grease.
- A diagonal cutter to trim excess wires. To avoid injury when cutting excess leads, hold the lead so they cannot fly towards the eyes.
- Needle nose pliers, for bending leads, or to hold components in place.
- Small blade and Phillips screwdrivers. A basic range is fine.

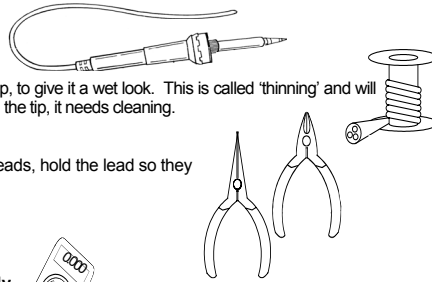

For some projects, a basic multi-meter is required, or might be handy

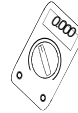

1.2 Assembly Hints :

- ⇒ Make sure the skill level matches your experience, to avoid disappointments.
- ⇒ Follow the instructions carefully. Read and understand the entire step before you perform each operation.
- ⇒ Perform the assembly in the correct order as stated in this manual
- ⇒ Position all parts on the PCB (Printed Circuit Board) as shown on the drawings.
- ⇒ Values on the circuit diagram are subject to changes.
- ⇒ Values in this assembly guide are correct*
- ⇒ Use the check-boxes to mark your progress.
- ⇒ Please read the included information on safety and customer service

* Typographical inaccuracies excluded. Always look for possible last minute manual updates, indicated as 'NOTE' on a separate leaflet.

1. Assembly (Skipping this can lead to troubles !)

Ok, so we have your attention. These hints will help you to make this project successful. Read them carefully.

1.1 Make sure you have the right tools:

- A good quality soldering iron (25-40W) with a small tip.
- Wipe it often on a wet sponge or cloth, to keep it clean; then apply solder to the tip, to give it a wet look. This is called 'thinning' and will protect the tip, and enables you to make good connections. When solder rolls off the tip, it needs cleaning.
- Thin raisin-core solder. Do not use any flux or grease.
- A diagonal cutter to trim excess wires. To avoid injury when cutting excess leads, hold the lead so they cannot fly towards the eyes.
- Needle nose pliers, for bending leads, or to hold components in place.
- Small blade and Phillips screwdrivers. A basic range is fine.

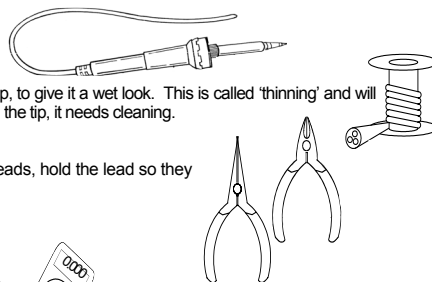

For some projects, a basic multi-meter is required, or might be handy



1.2 Assembly Hints :

- ⇒ Make sure the skill level matches your experience, to avoid disappointments.
- ⇒ Follow the instructions carefully. Read and understand the entire step before you perform each operation.
- ⇒ Perform the assembly in the correct order as stated in this manual
- ⇒ Position all parts on the PCB (Printed Circuit Board) as shown on the drawings.
- ⇒ Values on the circuit diagram are subject to changes.
- ⇒ Values in this assembly guide are correct*
- ⇒ Use the check-boxes to mark your progress.
- ⇒ Please read the included information on safety and customer service

* Typographical inaccuracies excluded. Always look for possible last minute manual updates, indicated as 'NOTE' on a separate leaflet.

1.3 Soldering Hints :

1- Mount the component against the PCB surface and carefully solder the leads

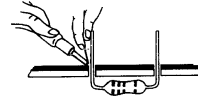

2- Make sure the solder joints are cone-shaped and shiny

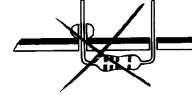
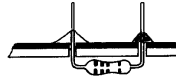

3- Trim excess leads as close as possible to the solder joint

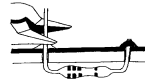

REMOVE THEM FROM THE TAPE ONE AT A TIME !

AXIAL COMPONENTS ARE TAPED IN THE CORRECT MOUNTING SEQUENCE !

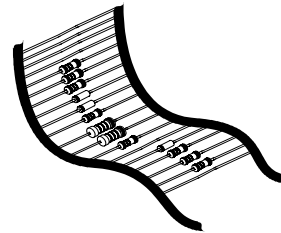

1.3 Soldering Hints :

1- Mount the component against the PCB surface and carefully solder the leads

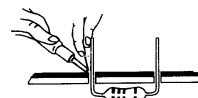

2- Make sure the solder joints are cone-shaped and shiny

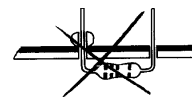
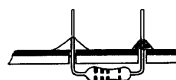

3- Trim excess leads as close as possible to the solder joint



REMOVE THEM FROM THE TAPE ONE AT A TIME !

AXIAL COMPONENTS ARE TAPED IN THE CORRECT MOUNTING SEQUENCE !

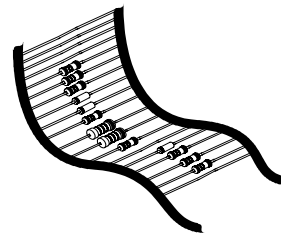

1. Diodes. Watch the polarity !

D1 : 1N4148
 D2 : 1N4148

2. Zenerdiode. Watch the polarity !

ZD1 : 9V1

3. Resistors

R1 : 47K (4 - 7 - 3 - B)
 R2 : 100 (1 - 0 - 1 - B)

<input type="checkbox"/> R3 : 3K3	(3 - 3 - 2 - B)
<input type="checkbox"/> R4 : 330	(3 - 3 - 1 - B)
<input type="checkbox"/> R5 : 220	(2 - 2 - 1 - B)
<input type="checkbox"/> R6 : 47	(4 - 7 - 0 - B)
<input type="checkbox"/> R7 : 680	(6 - 8 - 1 - B)
<input type="checkbox"/> R8 : 3K3	(3 - 3 - 2 - B)
<input type="checkbox"/> R9 : 3K3	(3 - 3 - 2 - B)
<input type="checkbox"/> R10: 10	(1 - 0 - 0 - B)
<input type="checkbox"/> R11: 3K3	(3 - 3 - 2 - B)
<input type="checkbox"/> R12: 1K5	(1 - 5 - 2 - B)
<input type="checkbox"/> R13: 3K3	(3 - 3 - 2 - B)
<input type="checkbox"/> R14: 1K8	(1 - 8 - 2 - B)
<input type="checkbox"/> R15: 1K	(1 - 0 - 2 - B)
<input type="checkbox"/> R16: 47	(4 - 7 - 0 - B)
<input type="checkbox"/> R17: 220	(2 - 2 - 1 - B)
<input type="checkbox"/> R18: 33K	(3 - 3 - 3 - B)

4. Transistor connections

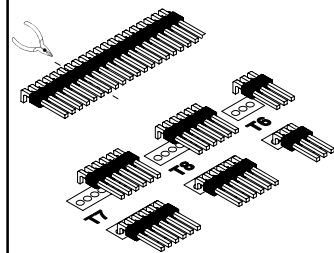

- ✓ Cut a piece of 3 pins (fig) of the pin header and mount it for **T6**
- ✓ Cut a piece of 6 pins and mount it for **T7**
- ✓ Cut a piece of 6 pins and mount it for **T8**

1. Diodes. Watch the polarity !

D1 : 1N4148
 D2 : 1N4148

2. Zenerdiode. Watch the polarity !

ZD1 : 9V1

3. Resistors

R1 : 47K (4 - 7 - 3 - B)
 R2 : 100 (1 - 0 - 1 - B)

<input type="checkbox"/> R3 : 3K3	(3 - 3 - 2 - B)
<input type="checkbox"/> R4 : 330	(3 - 3 - 1 - B)
<input type="checkbox"/> R5 : 220	(2 - 2 - 1 - B)
<input type="checkbox"/> R6 : 47	(4 - 7 - 0 - B)
<input type="checkbox"/> R7 : 680	(6 - 8 - 1 - B)
<input type="checkbox"/> R8 : 3K3	(3 - 3 - 2 - B)
<input type="checkbox"/> R9 : 3K3	(3 - 3 - 2 - B)
<input type="checkbox"/> R10: 10	(1 - 0 - 0 - B)
<input type="checkbox"/> R11: 3K3	(3 - 3 - 2 - B)
<input type="checkbox"/> R12: 1K5	(1 - 5 - 2 - B)
<input type="checkbox"/> R13: 3K3	(3 - 3 - 2 - B)
<input type="checkbox"/> R14: 1K8	(1 - 8 - 2 - B)
<input type="checkbox"/> R15: 1K	(1 - 0 - 2 - B)
<input type="checkbox"/> R16: 47	(4 - 7 - 0 - B)
<input type="checkbox"/> R17: 220	(2 - 2 - 1 - B)
<input type="checkbox"/> R18: 33K	(3 - 3 - 3 - B)

4. Transistor connections

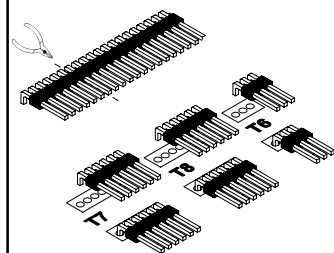

- ✓ Cut a piece of 3 pins (fig) of the pin header and mount it for **T6**
- ✓ Cut a piece of 6 pins and mount it for **T7**
- ✓ Cut a piece of 6 pins and mount it for **T8**

<p>5. Power diodes. Watch the polarity !</p> <ul style="list-style-type: none"> <input type="checkbox"/> D3 : 1N5404 <input type="checkbox"/> D4 : 1N5404 <input type="checkbox"/> D5 : 1N5404 <input type="checkbox"/> D6 : 1N5404 	<p>7. Trim potentiometer</p> <ul style="list-style-type: none"> <input type="checkbox"/> RV1 : 1K 	<p>10. PCB tabs.</p> <ul style="list-style-type: none"> <input type="checkbox"/> IN <input type="checkbox"/> GND
<p>6. Capacitors.</p> <ul style="list-style-type: none"> <input type="checkbox"/> C1 : 47pF (47) <input type="checkbox"/> C2 : 47pF (47) <input type="checkbox"/> C3 : 47pF (47) <input type="checkbox"/> C4 : 680pF (681) <input type="checkbox"/> C5 : 680pF (681) <input type="checkbox"/> C6 : 47nF (473) <input type="checkbox"/> C7 : 100nF (104) <input type="checkbox"/> C8 : 100nF (104) 	<p>8. Transistors.</p> <ul style="list-style-type: none"> <input type="checkbox"/> T1 : BC640 <input type="checkbox"/> T2 : BC640 <input type="checkbox"/> T3 : BC639 <input type="checkbox"/> T4 : BC547B <input type="checkbox"/> T5 : BC557B 	<p>11. Electrolytic Capacitors. Watch the polarity !</p> <ul style="list-style-type: none"> <input type="checkbox"/> C9 : 10µF <input type="checkbox"/> C10 : 100µF <input type="checkbox"/> C11 : 470µF
<p>9. LED. Watch the polarity!</p> <ul style="list-style-type: none"> <input type="checkbox"/> LD1 : Red 	<p>12. PCB terminals</p> <ul style="list-style-type: none"> <input type="checkbox"/> LS+ <input type="checkbox"/> LS- <input type="checkbox"/> AC (2x) <input type="checkbox"/> AC-0 (2x) 	

<p>5. Power diodes. Watch the polarity !</p> <ul style="list-style-type: none"> <input type="checkbox"/> D3 : 1N5404 <input type="checkbox"/> D4 : 1N5404 <input type="checkbox"/> D5 : 1N5404 <input type="checkbox"/> D6 : 1N5404 	<p>7. Trim potentiometer</p> <ul style="list-style-type: none"> <input type="checkbox"/> RV1 : 1K 	<p>10. PCB tabs.</p> <ul style="list-style-type: none"> <input type="checkbox"/> IN <input type="checkbox"/> GND
<p>6. Capacitors.</p> <ul style="list-style-type: none"> <input type="checkbox"/> C1 : 47pF (47) <input type="checkbox"/> C2 : 47pF (47) <input type="checkbox"/> C3 : 47pF (47) <input type="checkbox"/> C4 : 680pF (681) <input type="checkbox"/> C5 : 680pF (681) <input type="checkbox"/> C6 : 47nF (473) <input type="checkbox"/> C7 : 100nF (104) <input type="checkbox"/> C8 : 100nF (104) 	<p>8. Transistors.</p> <ul style="list-style-type: none"> <input type="checkbox"/> T1 : BC640 <input type="checkbox"/> T2 : BC640 <input type="checkbox"/> T3 : BC639 <input type="checkbox"/> T4 : BC547B <input type="checkbox"/> T5 : BC557B 	<p>11. Electrolytic Capacitors. Watch the polarity !</p> <ul style="list-style-type: none"> <input type="checkbox"/> C9 : 10µF <input type="checkbox"/> C10 : 100µF <input type="checkbox"/> C11 : 470µF
<p>9. LED. Watch the polarity!</p> <ul style="list-style-type: none"> <input type="checkbox"/> LD1 : Red 	<p>12. PCB terminals</p> <ul style="list-style-type: none"> <input type="checkbox"/> LS+ <input type="checkbox"/> LS- <input type="checkbox"/> AC (2x) <input type="checkbox"/> AC-0 (2x) 	

13. 5W resistors

- R19 : 0,47
- R20 : 0,47

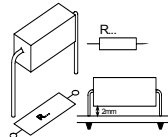

14. Electrolytic Capacitors. Watch the polarity !

- C12 : 3300µF
- C13 : 3300µF

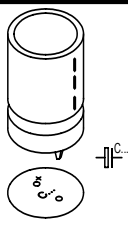

☞ Hint for tweekers :
 Replace the original caps with 4700µF/50V types for even better performance.

IMPORTANT

- ☞ Check the complete assembly carefully before mounting the heat sink.
- ☞ Once the heat sink is mounted, the solder-side is no longer accessible.

13. 5W resistors

- R19 : 0,47
- R20 : 0,47

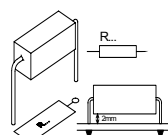

14. Electrolytic Capacitors. Watch the polarity !

- C12 : 3300µF
- C13 : 3300µF

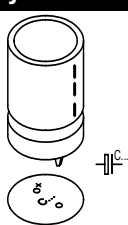

☞ Hint for tweekers :
 Replace the original caps with 4700µF/50V types for even better performance.

IMPORTANT

- ☞ Check the complete assembly carefully before mounting the heat sink.
- ☞ Once the heat sink is mounted, the solder-side is no longer accessible.

15. Final assembly

A custom pre-drilled heat sink is available from your distributor (order code HSVM100). Any other heat sink must be able to dissipate at least 30W (1.25°C/W) (see fig.1.0).

☞ Use the template as a drill guide.

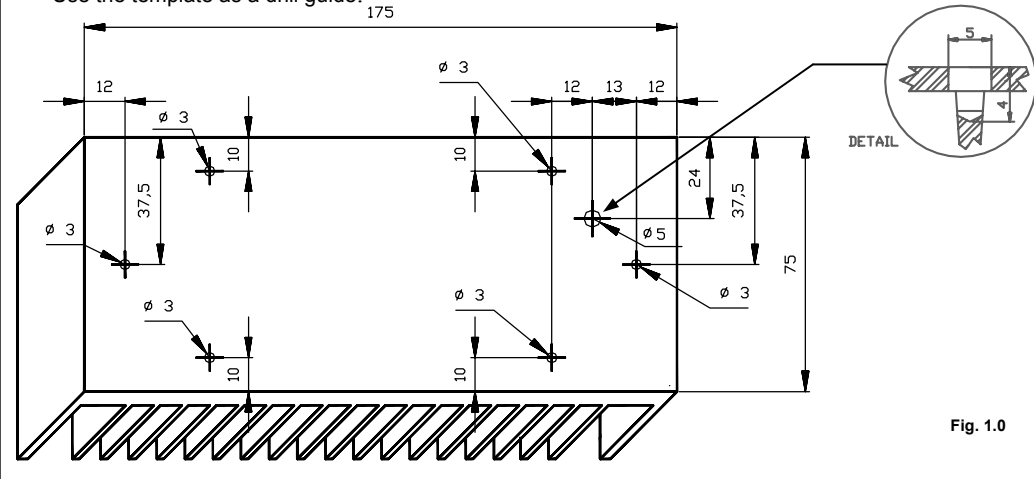

Fig. 1.0

15. Final assembly

A custom pre-drilled heat sink is available from your distributor (order code HSVM100). Any other heat sink must be able to dissipate at least 30W (1.25°C/W) (see fig.1.0).

☞ Use the template as a drill guide.

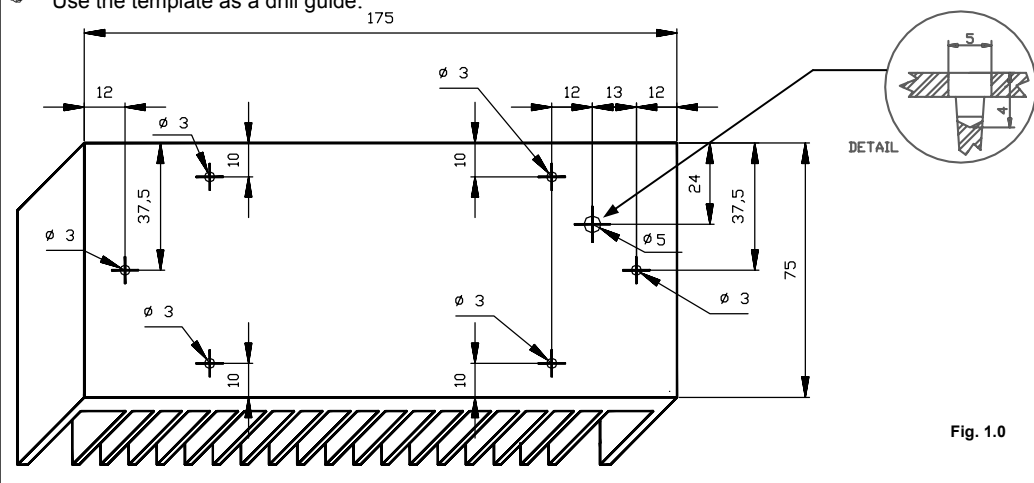

Fig. 1.0

- Mount 4 bolts + 8 nuts (PCB support). (fig.2.0)

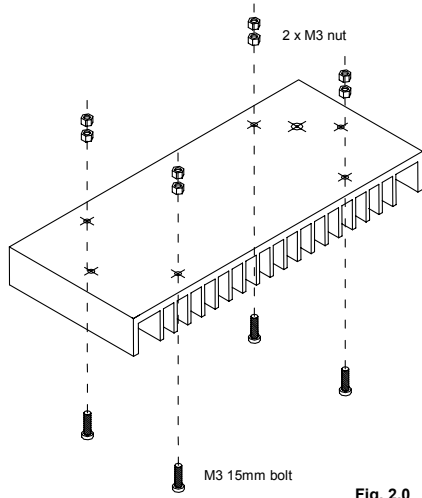

Fig. 2.0

- Slide the PCB over the 4 bolts, and fix using 4 nuts (Fig 3.0).

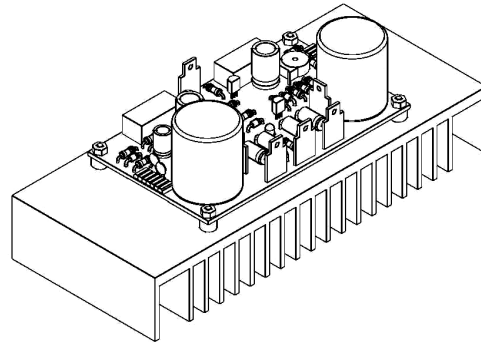

Fig. 3.0

- Mount 4 bolts + 8 nuts (PCB support). (fig.2.0)

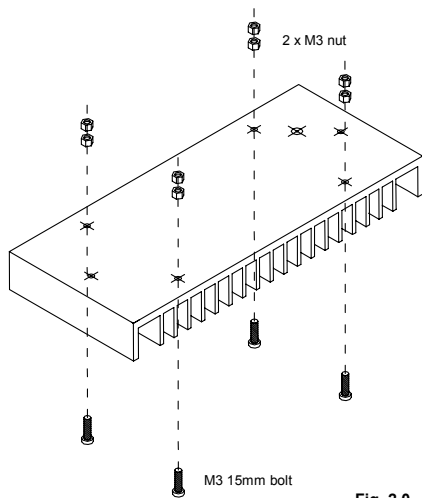

Fig. 2.0

- Slide the PCB over the 4 bolts, and fix using 4 nuts (Fig 3.0).

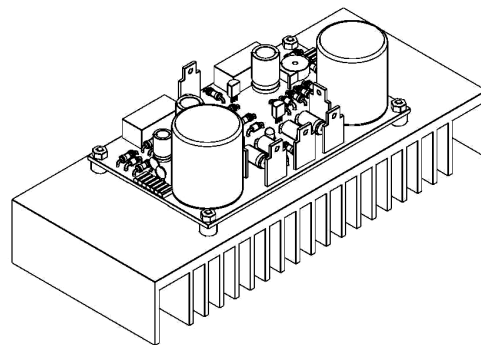

Fig. 3.0

16. Mounting the transistor T6 on the heat sink:

- Apply a drop of heat conductive compound in the heat sink hole (fig. 4.0).

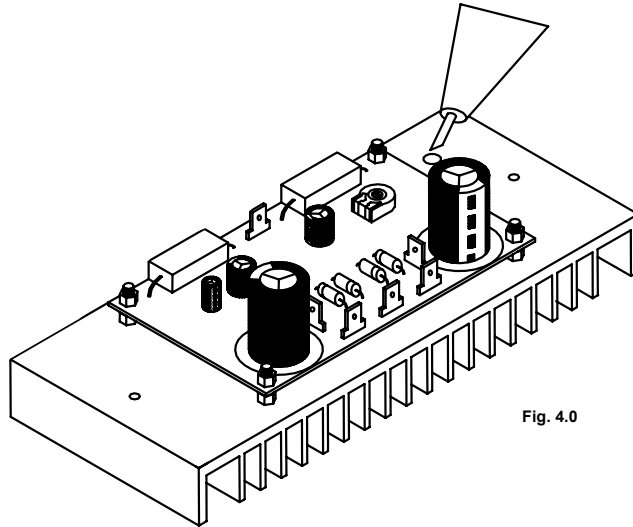

Fig. 4.0

10

16. Mounting the transistor T6 on the heat sink:

- Apply a drop of heat conductive compound in the heat sink hole (fig. 4.0).

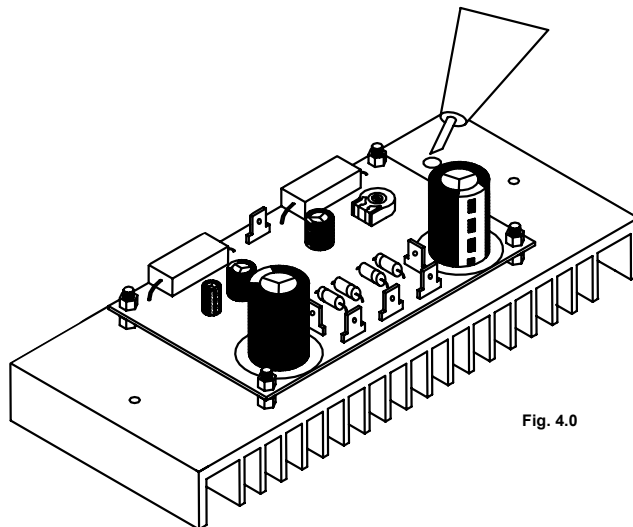

Fig. 4.0

10

- Insert the transistor (BC547) in the hole (Fig. 5.0). Pay attention to the position of the transistor (fig 6.0)!

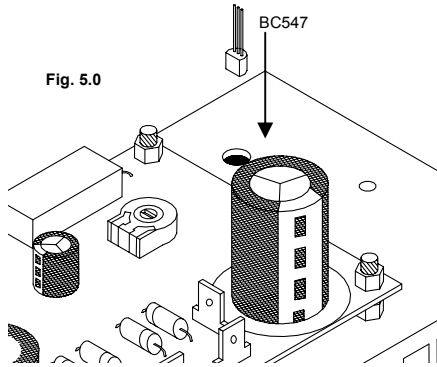

Fig. 5.0

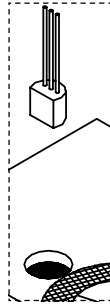

Fig. 6.0

- Carefully bend the leads and solder them to the connector T6, see figure 7.0.

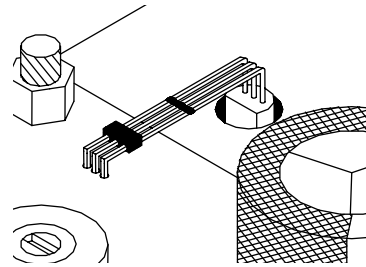

Fig. 7.0

- Insert the transistor (BC547) in the hole (Fig. 5.0). Pay attention to the position of the transistor (fig 6.0)!

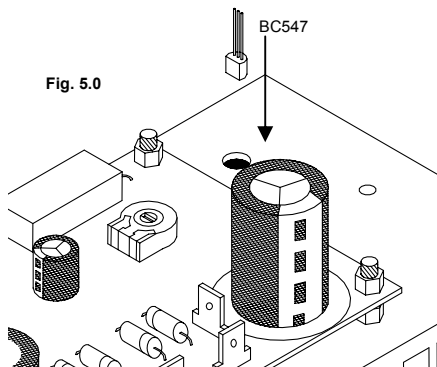

Fig. 5.0

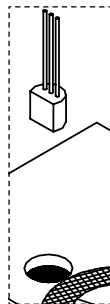

Fig. 6.0

- Carefully bend the leads and solder them to the connector T6, see figure 7.0.

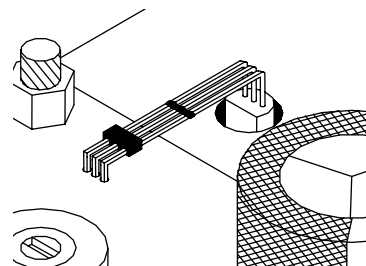

Fig. 7.0

17. Mounting of the power transistors T7 (TIP147) and T8 (TIP142).

- Apply a drop of heat conductive compound on the heat sink (see fig 8.0.)
- Mount the isolation mica onto the heat sink, check the position of the hole. Apply a drop of heat conductive compound on the mica.
- Carefully bend the leads, see fig. 9.0
- Mount the transistor on the heat sink, using a bolt, washer, lock washer and nut.

⚠ **IMPORTANT:** If metal body transistors are used, a plastic isolation washer must be applied (see 9.0.)

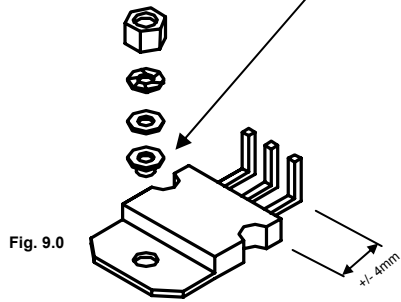

Fig. 9.0

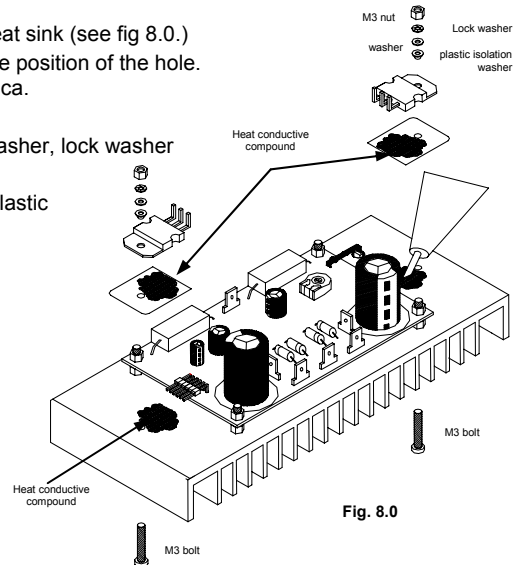

Fig. 8.0

17. Mounting of the power transistors T7 (TIP147) and T8 (TIP142).

- Apply a drop of heat conductive compound on the heat sink (see fig 8.0.)
- Mount the isolation mica onto the heat sink, check the position of the hole. Apply a drop of heat conductive compound on the mica.
- Carefully bend the leads, see fig. 9.0
- Mount the transistor on the heat sink, using a bolt, washer, lock washer and nut.

⚠ **IMPORTANT:** If metal body transistors are used, a plastic isolation washer must be applied (see 9.0.)

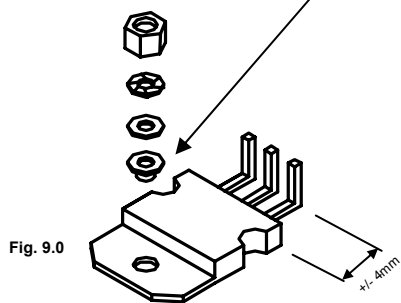

Fig. 9.0

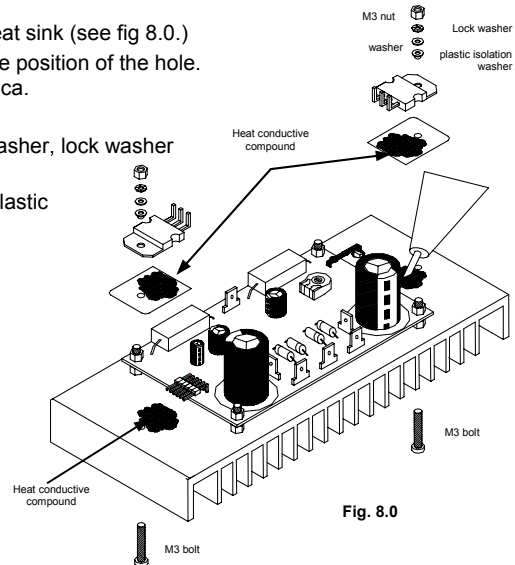

Fig. 8.0

- Solder the connections of the power transistors with the pin headers, see fig. 10.

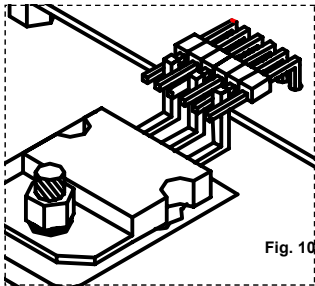
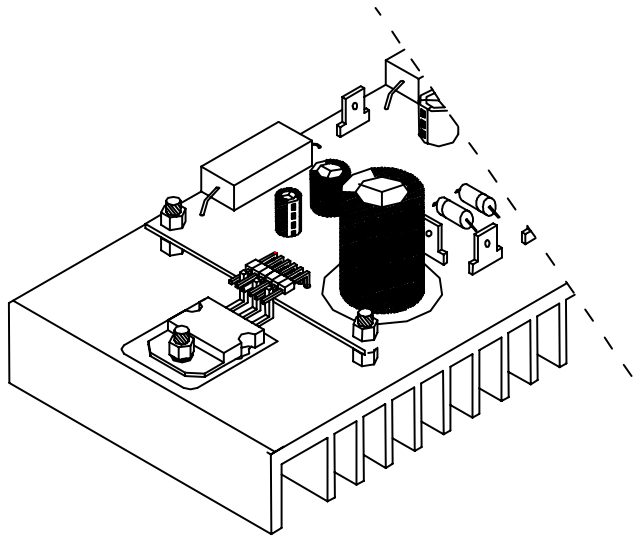

Fig. 10



- Solder the connections of the power transistors with the pin headers, see fig. 10.

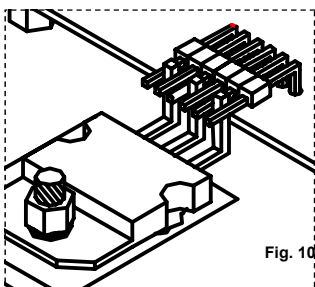
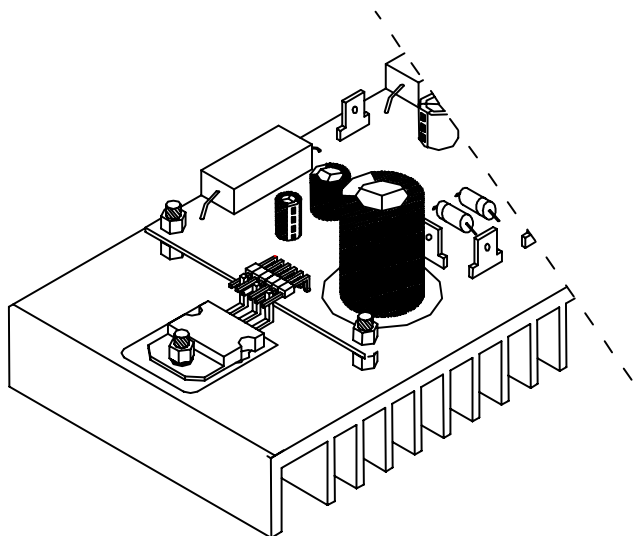

Fig. 10



18. Test and adjustments

- Use a 2 x 25 to 30Vac / 100 - 120VA transformer.
- Connect the transformer to the AC power connections of the PCB.
- The Velleman transformer colour scheme is specified on the pcb.

⚠ **Careful : Other brands may feature a different scheme !**

Y: yellow, R: red, B: blue, G: grey.

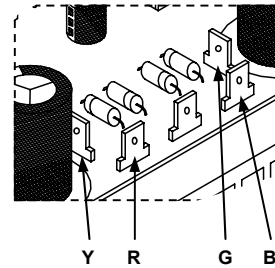
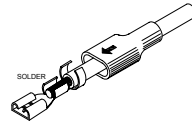

- Make sure to put a 1A T (slow-blow) fuse in series with the primary winding of the transformer (see diagram).

14

18. Test and adjustments

- Use a 2 x 25 to 30Vac / 100 - 120VA transformer.
- Connect the transformer to the AC power connections of the PCB.
- The Velleman transformer colour scheme is specified on the pcb.

⚠ **Careful : Other brands may feature a different scheme !**

Y: yellow, R: red, B: blue, G: grey.

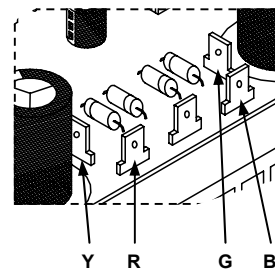
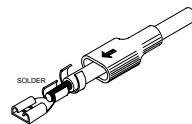

- Make sure to put a 1A T (slow-blow) fuse in series with the primary winding of the transformer (see diagram).

14

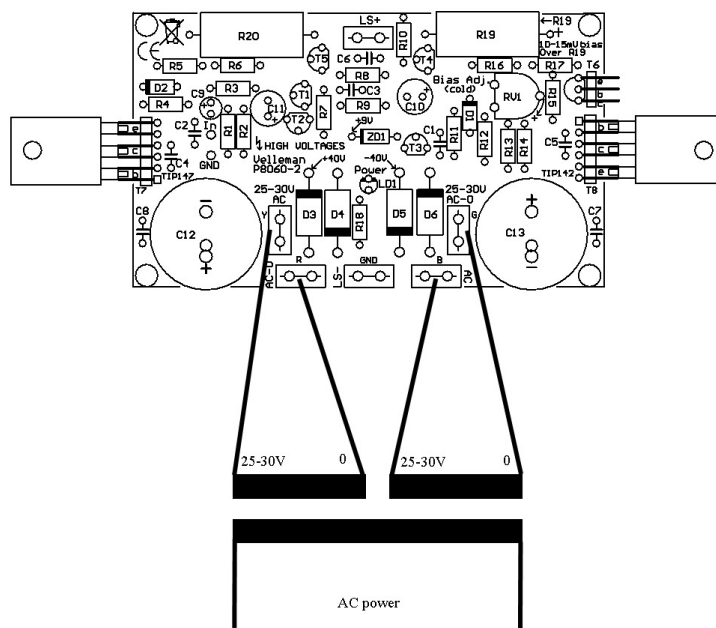
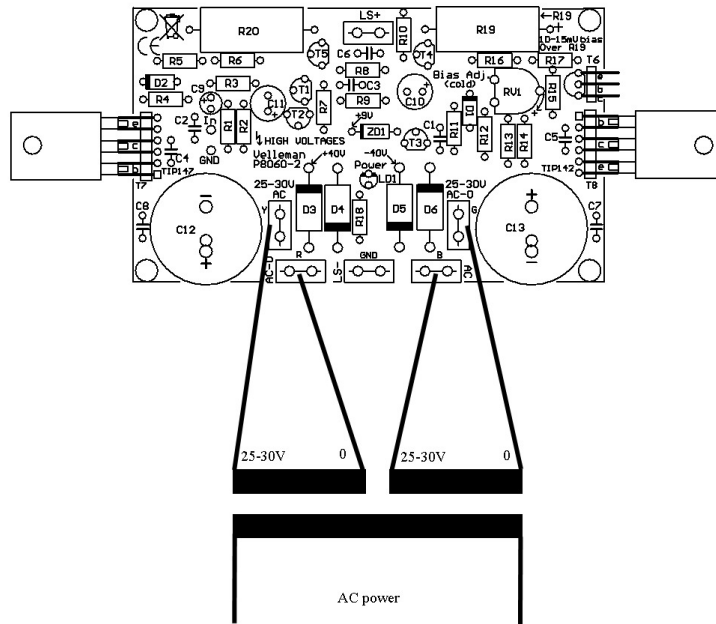

- Turn the RV1 bias adjust trimmer fully counter clockwise (turn left) before applying power for the first time.

👉 **ADVICE:** For safe first-time testing insert a 60W light bulb in series with the AC power and the transformer. If the light bulb lights up continuously, disconnect the transformer and check all your wiring and assembly. Reconnect the power supply. If the lamp remains off, everything is OK, replace the light bulb with a fuse.

If the TR8040 transformer is used there is a selection of primary AC voltage :

- 120Vac:** black / brown.
- 230Vac:** black/orange.

👉 **IMPORTANT:** Insulate the wire that is not being used.

👉 **NOTE:** Two amplifiers and two transformers are required for stereo. Never attempt to run two amplifiers from a single transformer!

Setting the bias:

- Connect a multimeter (lowest DC voltage range 1V or lower) over the leads of R19 (polarity is indicated on the PCB).
- Turn on the power, the power LED should light.
- Check the multimeter, it should read 0V, adjust RV1 carefully to about 10mV (0.01V) Wait a few minutes until the meter reading remains stable.
- Turn off the AC power. The amplifier is now ready for use.

16

- Turn the RV1 bias adjust trimmer fully counter clockwise (turn left) before applying power for the first time.

👉 **ADVICE:** For safe first-time testing insert a 60W light bulb in series with the AC power and the transformer. If the light bulb lights up continuously, disconnect the transformer and check all your wiring and assembly. Reconnect the power supply. If the lamp remains off, everything is OK, replace the light bulb with a fuse.

If the TR8040 transformer is used there is a selection of primary AC voltage :

- 120Vac:** black / brown.
- 230Vac:** black/orange.

👉 **IMPORTANT:** Insulate the wire that is not being used.

👉 **NOTE:** Two amplifiers and two transformers are required for stereo. Never attempt to run two amplifiers from a single transformer!

Setting the bias:

- Connect a multimeter (lowest DC voltage range 1V or lower) over the leads of R19 (polarity is indicated on the PCB).
- Turn on the power, the power LED should light.
- Check the multimeter, it should read 0V, adjust RV1 carefully to about 10mV (0.01V) Wait a few minutes until the meter reading remains stable.
- Turn off the AC power. The amplifier is now ready for use.

16

Final connection:

- The input (GND and in) can be connected directly to an audio source (pre-amp or mixing panel) or a volume control (potentiometer) can be used (see diagram).
- Connect the speaker (4 ohm or higher) to the connections LS+ and GND.

⚠ **CAUTION:** VOLTAGES OF ABOUT 80V ARE PRESENT. MAKE SURE TO USE A SUITABLE ENCLOSURE AND ISOLATE ALL AC CONNECTIONS

Final connection:

- The input (GND and in) can be connected directly to an audio source (pre-amp or mixing panel) or a volume control (potentiometer) can be used (see diagram).
- Connect the speaker (4 ohm or higher) to the connections LS+ and GND.

⚠ **CAUTION:** VOLTAGES OF ABOUT 80V ARE PRESENT. MAKE SURE TO USE A SUITABLE ENCLOSURE AND ISOLATE ALL AC CONNECTIONS

19. Diagram

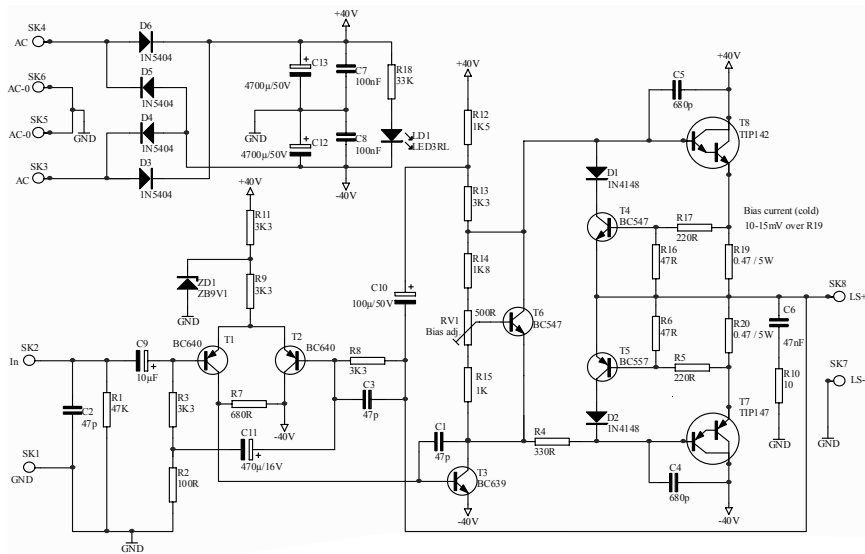

18

19. Diagram

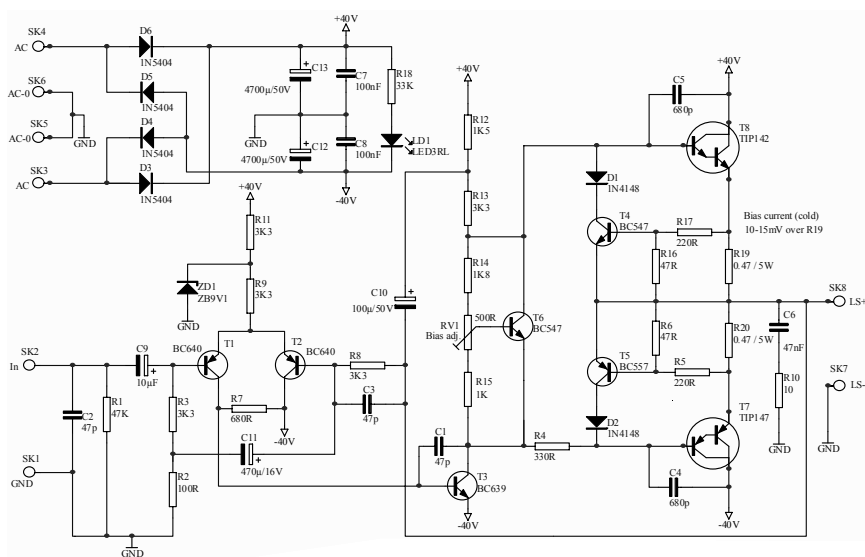

18





Modifications and typographical errors reserved
© Velleman Components nv.
H8060IP - 2005 - ED1 (rev.1)



Modifications and typographical errors reserved
© Velleman Components nv.
H8060IP - 2005 - ED1 (rev.1)



X-ON Electronics

Largest Supplier of Electrical and Electronic Components

Click to view similar products for [Velleman](#) manufacturer:

Other Similar products are found below :

[MK137](#) [MK106](#) [K/TRANS1](#) [K/RES-E3](#) [K/TF300](#) [MK108](#) [K2634](#) [MK152](#) [MK123](#) [K8086](#) [MK149](#) [VM100](#) [MK144](#) [MK190](#) [K1803](#)
[MK134](#) [K/CAP1](#) [MK111](#) [OMSB36](#) [MK103](#) [K/DIODE1](#) [MK109](#) [MK135](#) [MK150](#) [MK112](#) [MK120](#) [K/RES-E12](#) [VTHH6](#)