



VIA Labs, Inc.

Data sheet

VL151 (A3)

E-Marker for USB Type-C Cable

October 13th, 2016

Revision 1.3



Revision History

Rev	Date	Note	Initial
0.60	8/14/2015	Preliminary Release	TH
0.70	8/17/2015	Add DFN-8 Package information	AY
0.80	12/3/2015	Add Certificate No and order information	TH
0.90	5/21/2016	Add WLCSP-6 Package information	AY
1.0	5/24/2016	Version 1.0 release	TH
1.1	7/30/2016	Update A3 revision	TH
1.2	9/20/2016	Add Lead(Pb)-Free and RoHS compliant	TH
1.3	10/13/2016	Add WLCSP-6 thermal data	TH

ALL CONFIDENTIAL

Contents

Product Feature	- 4 -
Block Diagram	- 5 -
Pinout	- 6 -
Pin List	- 9 -
Pin Descriptions	- 10 -
Electrical Specification	- 11 -
Electrical Characteristics	- 12 -
Default VDM Register Map	- 13 -
General Reflow Profile Guidelines	- 15 -
Package Mechanical Specifications	- 16 -
Package Top Side Marking	- 19 -
Ordering Information.....	- 20 -
Tape and Reel Information	- 21 -

List of Figures

Figure 1 - Block Diagram	- 5 -
Figure 2 - Pin Diagram (DFN-10)	- 6 -
Figure 3 - Pin Diagram (DFN-8)	- 7 -
Figure 4 - Pin Diagram (WLCSP-6)	- 8 -
Figure 5 - Reflow	- 15 -
Figure 6 - Mechanical Specification (DFN-10).....	- 16 -
Figure 7 - Mechanical Specification (DFN-8)	- 17 -
Figure 8 - Mechanical Specification (WLCSP-6)	- 18 -
Figure 9 - Package Top Side Marking	- 19 -
Figure 10 - Tape & Reel Information	- 21 -

Product Feature

VL151

Electronic Marker for USB Type-C Passive Cable

■ PD 2.0 Compliant

- Compliant to USB Power Delivery 2.0 Specification
- SOP' Endpoint
- Supports Programming over CC Line using Unstructured Vendor Defined Messages

■ Sideband Signal Support

- Supports SMBus for Programming and Debugging

■ Easy Manufacturability

- DFN-10 3x3mm/DFN-8 2x3mm features 0.5mm pin pitch for easy manufacturing
- WLCSP-6 1.2x1.25mm with 0.4mm pin pitch to minimize paddle card size.
- Compatible with standard PCB Process
- TOTP Programming Support over CC or SMBus
- Extremely Low BOM Cost: Diodes, Ra are all integrated On-Die
- Compatible with Third-Party Programming Tools

■ TOTP Memory Onboard

- Supports Triple-Time Writable memory to store Cable VDO, Certification Status VDO, Product VDO, etc.
- Features write-protection support so finished cables cannot be modified
- TOTP memory is the best choice for data-retention and longevity, can programing three times

■ Applications

- Passive USB Type-C Cables such as Full-Featured C-to-C cables
- This IC is not intended for use in combo PD 1.0 and PD 2.0 applications

■ Certification

- Earned USB-IF certification TID #1097029 XID #0000892

■ Misc

- Optimized for Low Power consumption

■ Lead(Pb)-Free and RoHS compliant

Block Diagram

Figure 1 - Block Diagram

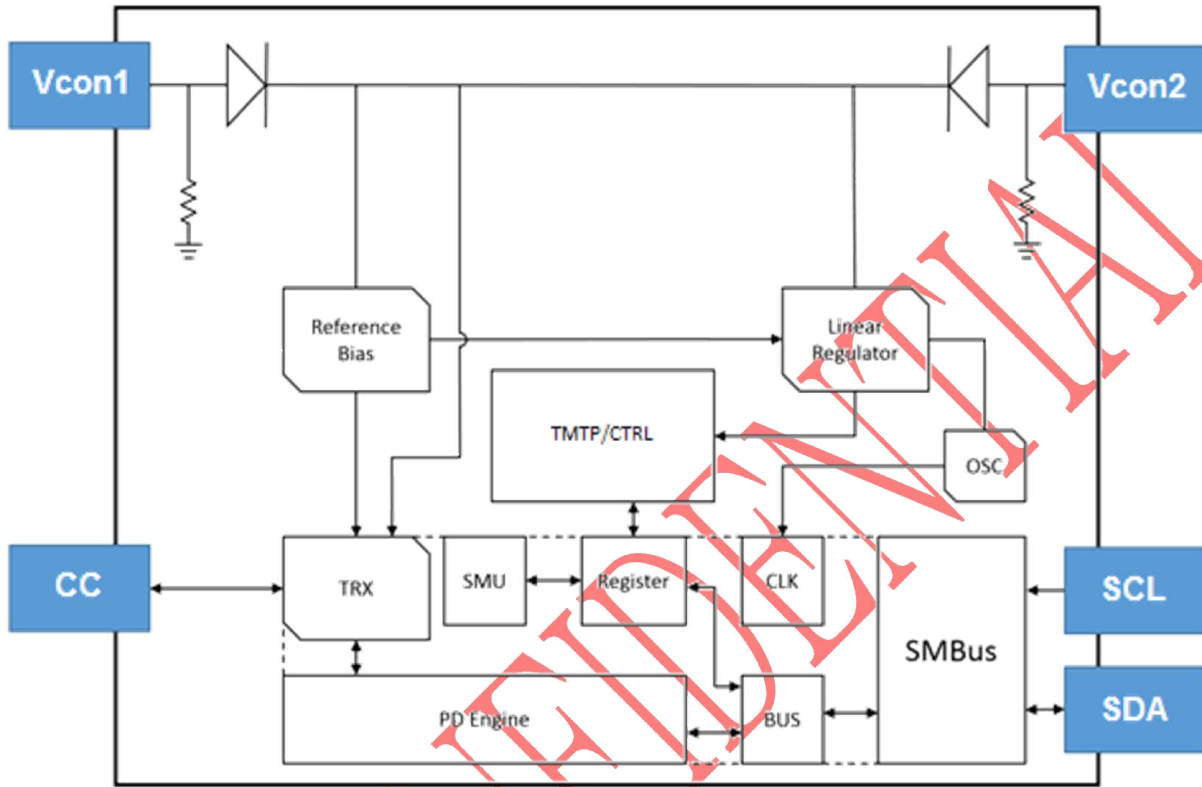

Pinout



Figure 2 - Pin Diagram (DFN-10)

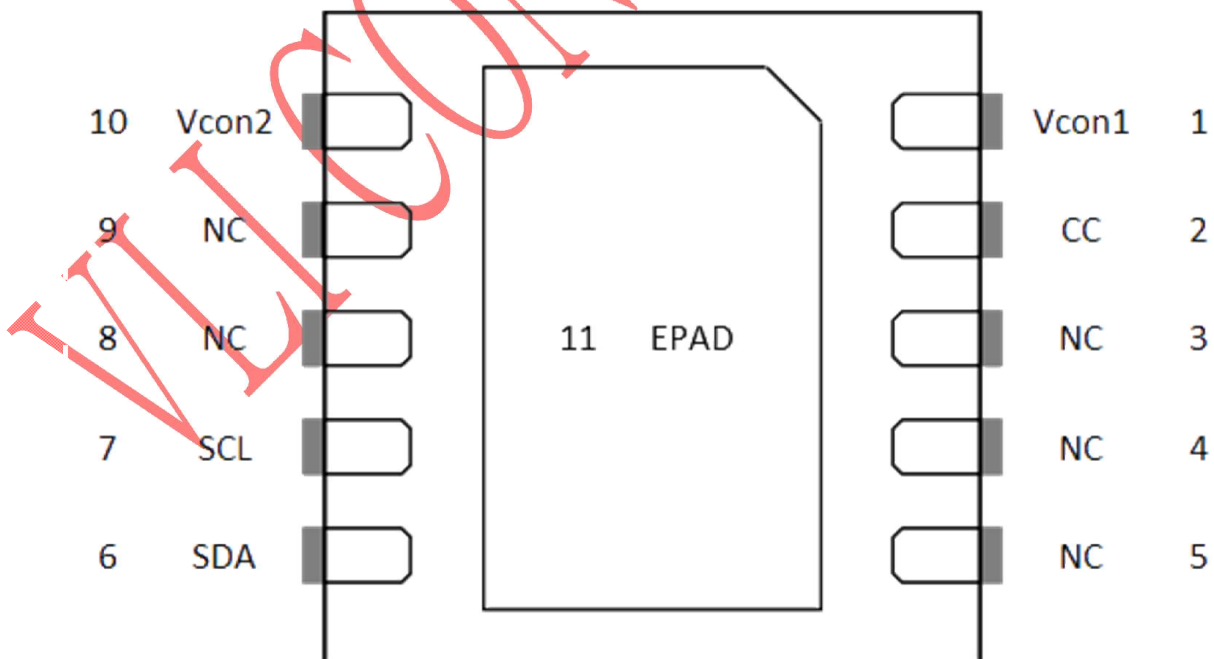
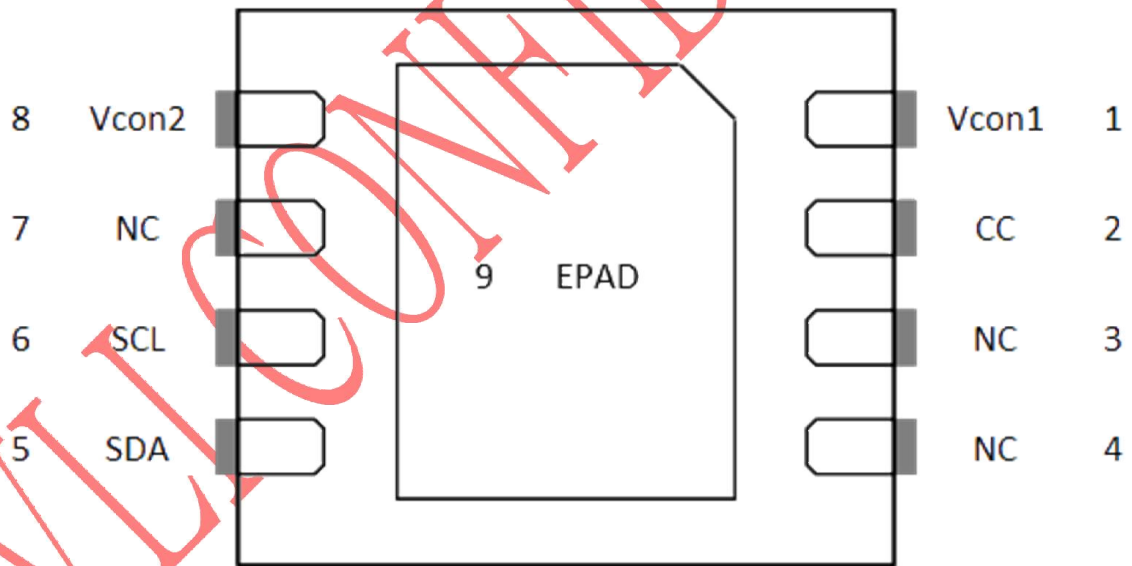



Figure 3 - Pin Diagram (DFN-8)



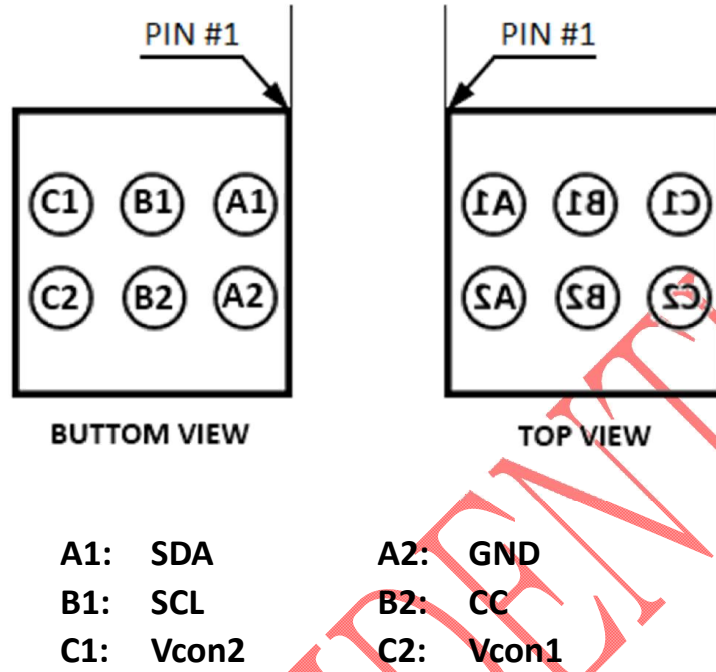

Figure 4 - Pin Diagram (WLCSP-6)

Pin List

DFN-10

Pin	Pin Name	Pin	Pin Name
1	VCON1	6	SDA
2	CC	7	SCL
3	NC	8	NC
4	NC	9	NC
		10	VCON2

DFN-8

Pin	Pin Name	Pin	Pin Name
1	VCON1	5	SDA
2	CC	6	SCL
3	NC	7	NC
4	NC	8	Vcon2
		9	EPAD

WLCSP-6

Pin	Pin Name	Pin	Pin Name
A1	SDA	A2	GND
B1	SCL	B2	CC
C1	VCON2	C2	VCON1

Pin Descriptions

Signal Type Definition

Name	Type	Signal Description
Input	I	A logic input-only signal
Output	O	A logic output only signal
Input/Output	I/O	A logic bi-directional signal
Power	PWR	A power pin
Ground	GND	A ground pin

Type-C Interface

Pin Name	Pin # DFN-10	Pin # DFN-8	Pin # WLCSP-6	I/O	Signal Description
Vcon1	1	1	C2	PWR	VCONN Power (Near Side)
CC	2	2	B2	I/O	CC communication line
Vcon2	10	8	C1	PWR	VCONN Power (Far Side)

Sideband & Miscellaneous

Pin Name	Pin # DFN-10	Pin # DFN-8	Pin # WLCSP-6	I/O	Signal Description
SCL	7	6	B1	I	SMBus Clock (Open Drain)
SDA	6	5	A1	I/O	SMBus Data (Open Drain)
NC	3,4,5,8,9	3,4,7	-	-	Not Connected (Float)

Ground

Pin Name	Pin # DFN-10	Pin # DFN-8	Pin # WLCSP-6	I/O	Signal Description
EPAD	11	9	A2	GND	Exposed Pad; System Ground

Electrical Specification

Absolute Maximum Rating

Symbol	Parameter	Min	Max	Unit	Note
T _{STG}	Storage Temperature	-55	125	°C	-
V _{CON1/2}	VCONN	-0.5	7	V	-
V _{ESD}	Electrostatic Discharge	-8000	8000	V	Human Body Model
θ _{jc}	Thermal resistance between junction and case	72.8	-	°C/W	4L PCB definitions follow JESD51-7 for WLCSP
P _D	Max Power Dissipation	-	1.24	W	

Note: Stress above conditions may cause permanent damage to the device.
Functional operation of this device should be restricted to the conditions described.

Note: About thermal factors, T_a is the concerned ambient temperature, and

$$\theta_{ca} = \theta_{ja} - \theta_{jc}$$

$$T_j = \theta_{ja} * P_D + T_a$$

$$T_c = \theta_{ca} * P_D + T_a$$

Operating Conditions

Symbol	Parameter	Min	Max	Unit	Note
T _A	Ambient Temperature	-25	85	°C	-
T _J	Junction Temperature	0	125	°C	-
V _{CON1/2}	VCONN	4.0	5.5	V	-
P _D	Power Consumption – operation	-	70	mW	-
P _D	Power Consumption - Suspend	-	7.5	mA	-

Electrical Characteristics

VDD=5V, TA=25°C (unless otherwise noted)

Common Normative Signaling Requirements						
Symbol	Parameter	Test Condition	Min	Typ	Max	Unit
fBitRate	Bit rate	-	270	300	33	kbps
pBitRate	Maximum difference between the bit-rate during the part of the packet following the Preamble and the reference bit-rate.	-			0.25	%
tInterFrameGap	Time from the end of last bit of a Frame until the start of the first bit of the next Preamble.	-	25			us
tStartDrive	Time before the start of the first bit of the Preamble when the transmitter shall start driving the line.	-	-1		1	us

ALL CONFIDENTIAL

Default VDM Register Map

This table shows the default VDM TMTP section address mapping to Discover Identity Command ACK response message, which VL151 sends when receiving a Discover Identity command, if VL151 has not been programmed. Once VL151 TMTP is programmed, the default values will be discarded and VL151 will respond to Discover Identity command with the programmed values.

Address	bits	Description
Cable VDO		
0x8010	[7:4]	HW Version Number, assigned by vendor, 0000b...1111b. 0000b [Default]
	[3:0]	Firmware Version Number, assigned by vendor, 0000b...1111b 0000b [Default]
0x8011	[7:4]	Reserved 0000b [Default]
	[3:2]	Type-C Plug to Type-A/B/C/Captive 00b = Type-A 01b = Type-B 10b = Type-C [Default] 11b = Captive
	[1]	Type-C Plug to Plug/Receptacle 0 = Plug [Default] 1 = Receptacle
	[0]	Cable Latency 0000b - Reserved, shall not be used 0001b - <10ns (~1m) [Default] 0010b - 10ns to 20ns (~2m) 0011b - 20ns to 30ns (~3m) 0100b - 30ns to 40ns (~4m) 0101b - 40ns to 50ns (~5m) 0110b - 50ns to 60ns (~6m) 0111b - 60ns to 70ns (~7m) 1000b - 1000ns (~100m) 1001b - 2000ns (~200m) 1010b - 3000ns (~300m) 1011b1111b Reserved, shall not be used Includes latency of electronics in Active Cable
0x8012	[4:3]	Cable Termination Type 00b = Both ends Passive, VCONN not required 01b = Both ends Passive, VCONN required [Default] 10b = One end Active, one end passive, VCONN required 11b = Both ends Active, VCONN required
	[2]	SSTX1 Directionality Support 0 = Fixed [Default] 1 = Configurable
	[1]	SSTX2 Directionality Support 0 = Fixed [Default] 1 = Configurable
	[0]	SSRX1 Directionality Support 0 = Fixed [Default] 1 = Configurable

Address	bits	Description
0x8013	[7]	SSRX2 Directionality Support 0 = Fixed [Default] 1 = Configurable
	[6:5]	VBUS Current Handling Capability 00b = VBUS not through cable 01b = 3A [Default] 10b = 5A 11b = Reserved, shall not be used.
	[4]	VBUS through cable 0 = No 1 = Yes [Default]
	[3]	SOP" controller present 1 = SOP" controller present 0 = No SOP" controller present [Default]
	[2:0]	USB Superspeed Signaling Support 000b = USB 2.0 only 001b = USB 3.1 Gen1 010b = USB 3.1 Gen1 and Gen2 [Default] 011b.. 111b = Reserved, shall not be used
Product VDO		
0x8014	[7:0]	USB Product ID, 16-bit unsigned integer, assigned by the cable vendor 0000000b, 0000000b [Default]
0x8015	[7:0]	
0x8016	[7:0]	Device version, bcdDevice , 16-bit unsigned integer, assigned by the cable vendor 0000000b, 0000000b [Default]
0x8017	[7:0]	
Cert Stat VDO		
0x8020	[7:0]	Reserved 0000000b [Default]
0x8021	[7:4]	Reserved 0000b [Default]
	[3:0]	TID assigned by USB-IF, 20-bit unsigned integer 0000b, 0000000b, 0000000b [Default]
0x8022	[7:0]	
0x8023	[7:0]	
ID Header		
0x8024	[7]	Data Capable as USB Host <ul style="list-style-type: none"> ● Shall be set to one if the product is capable of enumerating USB Devices. ● Shall be set to zero otherwise. 0b [Default]
	[6]	Data Capable as a USB Device <ul style="list-style-type: none"> ● Shall be set to one if the product is capable of enumerating as a USB Device. ● Shall be set to zero otherwise 0b [Default]
	[5:3]	Product Type 000b – Undefined 001b–Hub 010b–Peripheral 011b–Passive Cable [Default] 100b–Active Cable 101b–Alternate Mode Adapter (AMA) 110b...111b–Reserved, shall not be used.
	[2:0]	Reserved
0x8025	[7:1]	000b, 000000b [Default]
	[0]	Modal Operation Supported <ul style="list-style-type: none"> ● Shall be set to one if the product supports Modal Operation. ● Shall be set to zero otherwise 0b [Default]
0x8026	[7:0]	USB Vendor ID, 16-bit unsigned integer 00100001b(21), 00001001b(09) [Default]

General Reflow Profile Guidelines

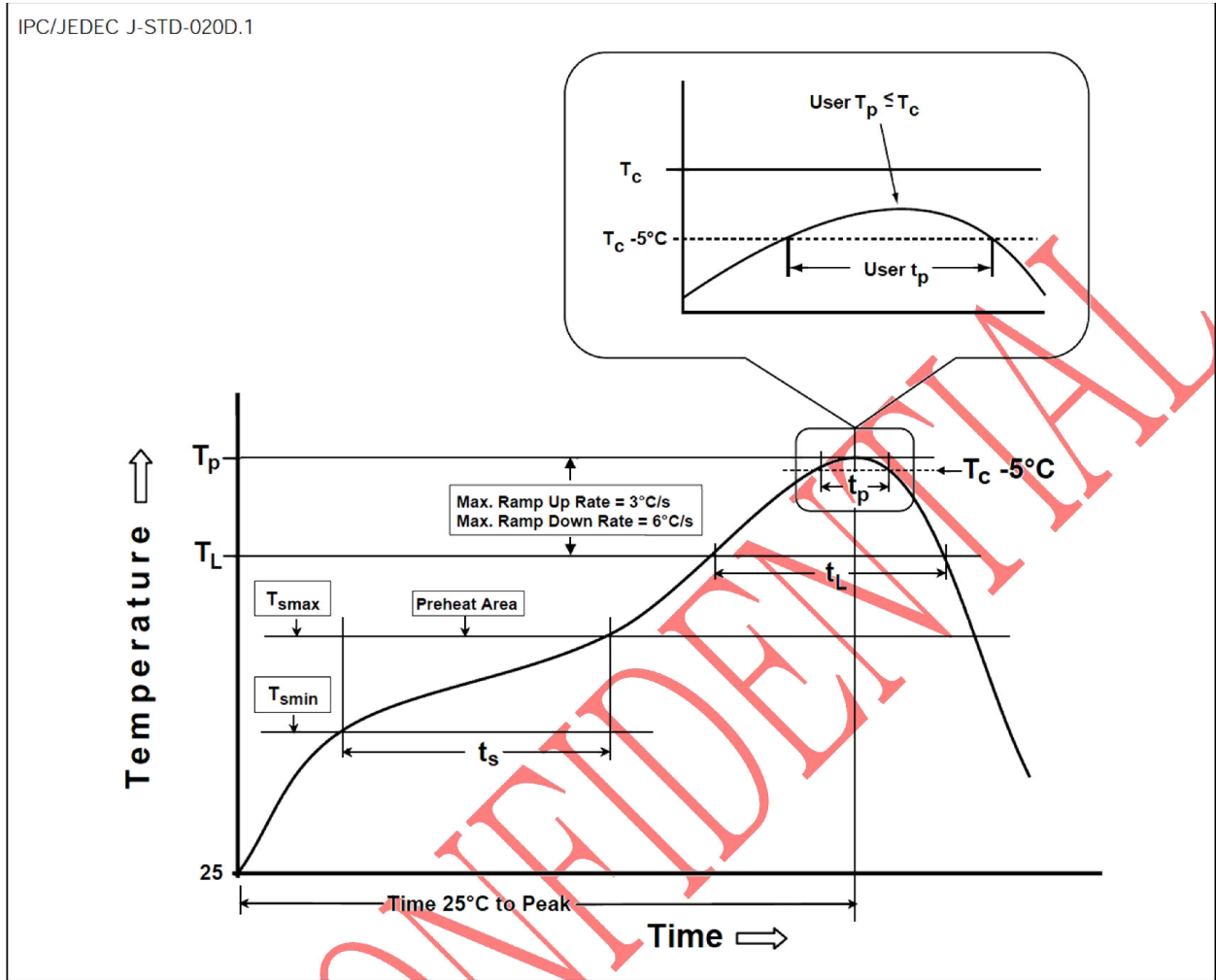

Profile Feature	Sn-Pb Eutectic Assembly	Pb-Free Assembly
Preheat/Soak		
Temperature Min (T_{smin})	100 °C	150 °C
Temperature Max (T_{smax})	150 °C	200 °C
Time (t_s) from (T_{smin} to T_{smax})	60-120 seconds	60-120 seconds
Ramp-up rate (T_L to T_p)	3 °C/second max.	3 °C/second max.
Liquidous temperature (T_L)	183 °C	217 °C
Time (t_L) maintained above T_L	60-150 seconds	60-150 seconds
Peak package body temperature (T_p)	225 °C	250 °C
Classification temperature (T_c)	230 °C	255 °C
Time (t_p)* within 5 °C of the specified classification temperature (T_c)	20* seconds	30* seconds
Ramp-down rate (T_p to T_L)	6 °C/second max.	6 °C/second max.
Time 25 °C to peak temperature	6 minutes max.	8 minutes max.

Note 1: All temperatures refer to the center of the package, measured on the package body surface that is facing up during assembly reflow (e.g., live-bug).

Figure 5 - Reflow

Package Mechanical Specifications

DFN-10

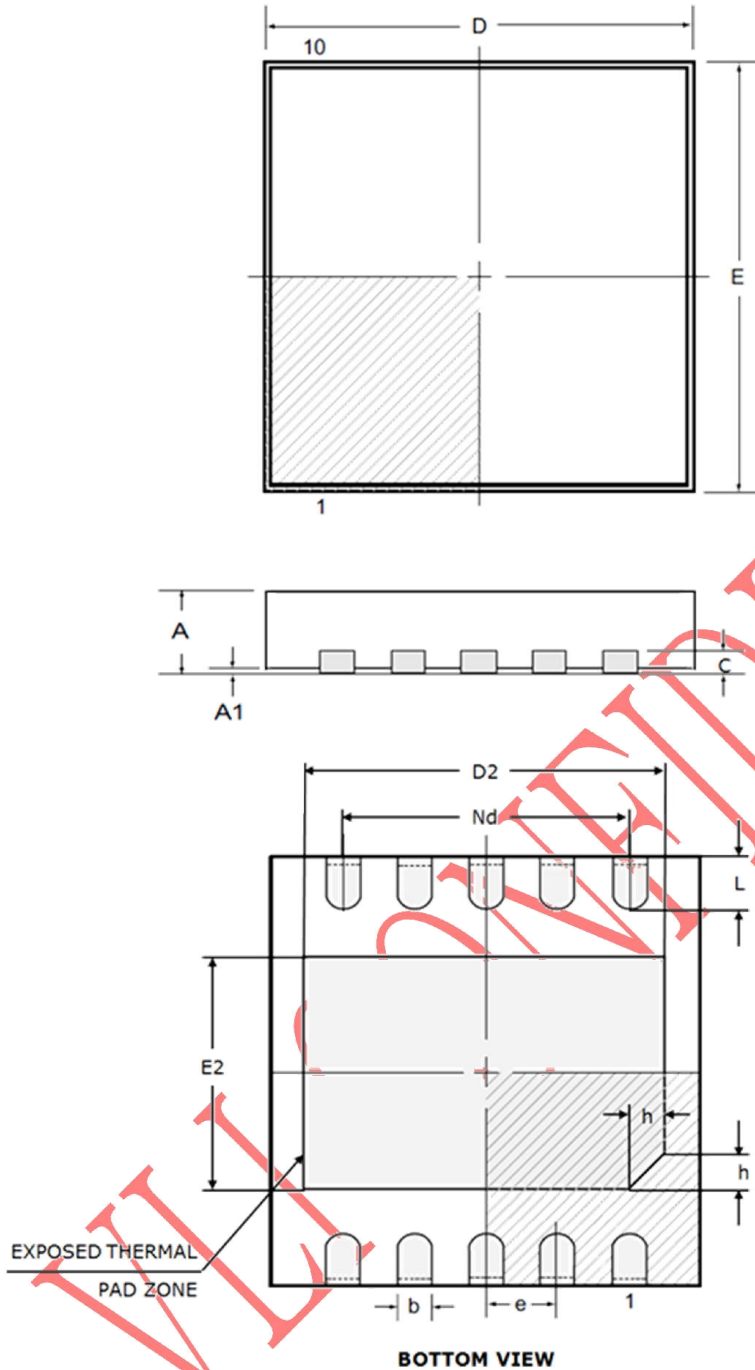

SYMBOL	MILLIMETER		
	MIN	NOM	MAX
A	0.70	0.75	0.80
A1	-	0.02	0.05
b	0.18	0.25	0.30
c	0.18	0.20	0.25
D	2.90	3.00	3.10
D2	2.40	2.50	2.60
e	0.50 BSC		
Nd	2.00 BSC		
E	2.90	3.00	3.10
E2	1.45	1.55	1.65
L	0.30	0.40	0.50
h	0.20	0.25	0.30

Figure 6 - Mechanical Specification (DFN-10)

DFN-8

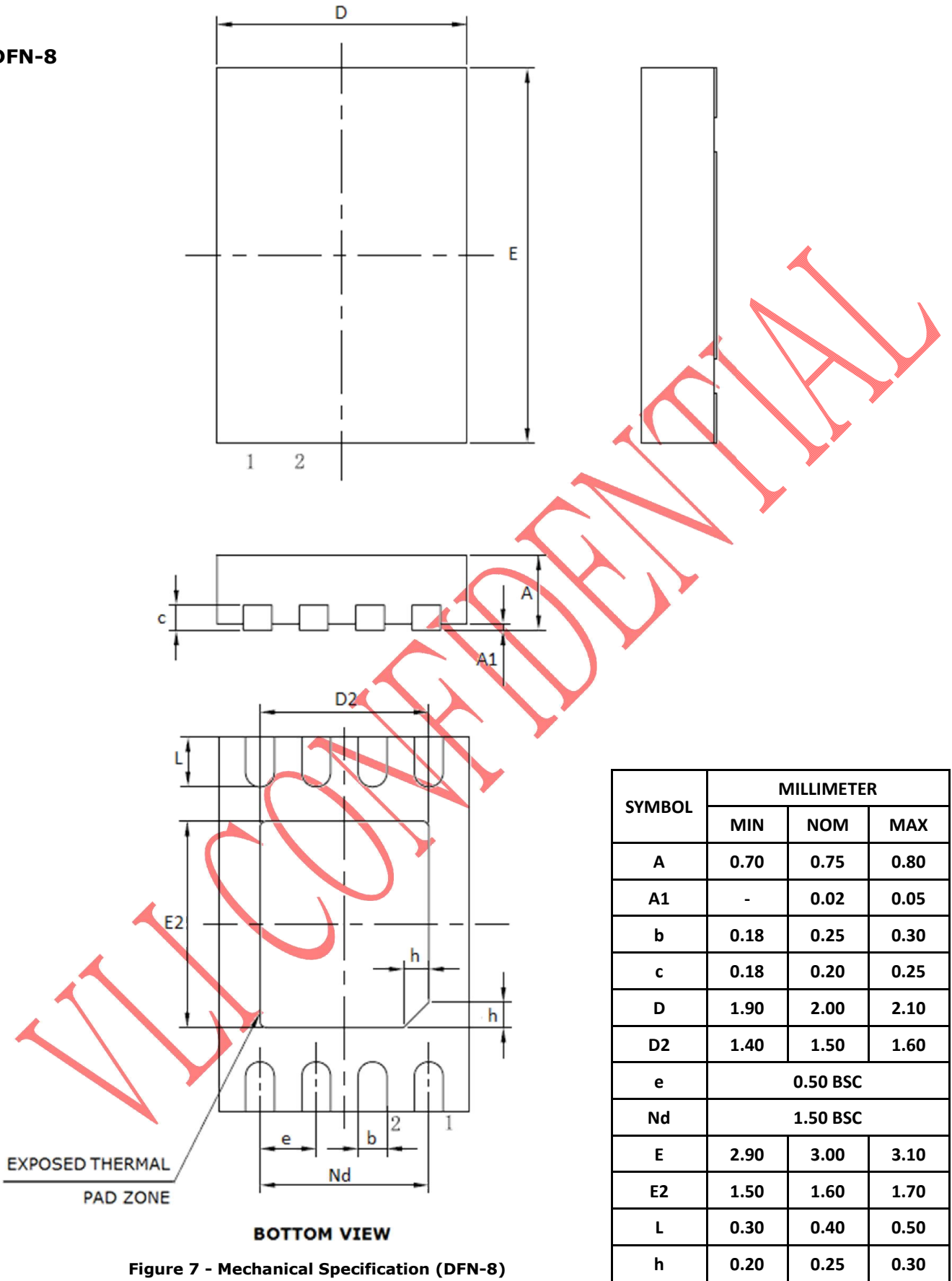
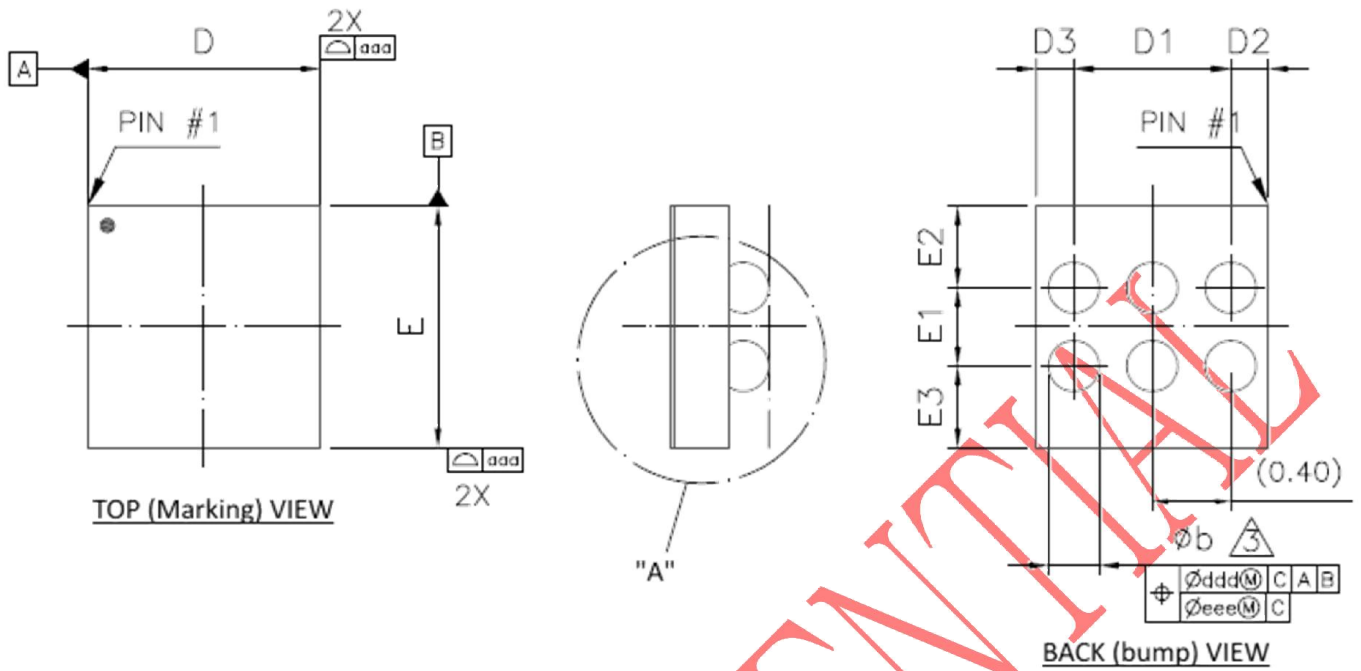

Figure 7 - Mechanical Specification (DFN-8)

WLCSP-6



SYMBOL	MILLIMETER		
	MIN	NOM	MAX
A	0.473	0.502	0.532
A1	0.185	0.200	0.215
c	0.255	0.280	0.306
c1	0.019	0.022	0.025
D	1.130	1.185	1.210
E	1.180	1.235	1.260
b	0.230	0.260	0.290
D1	-	0.799	-
E1	-	0.399	-
D2	-	0.193	-
E2	-	0.418	-
D3	-	0.193	-
E3	-	0.418	-
aaa	0.10		
bbb	0.10		
ccc	0.03		
ddd	0.15		
eee	0.05		

Figure 8 - Mechanical Specification (WLCSP-6)

Package Top Side Marking

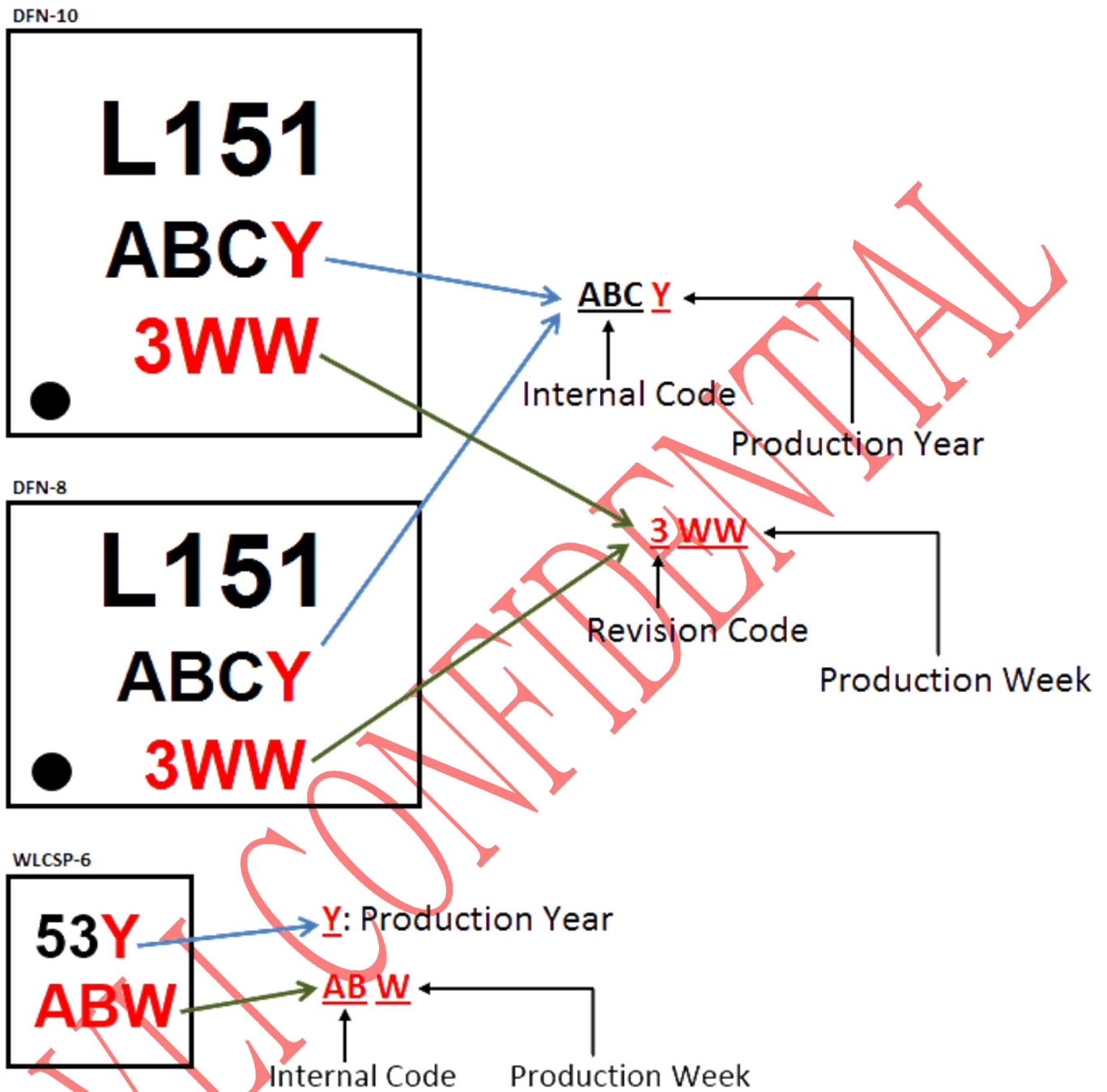

Figure 9 - Package Top Side Marking

Ordering Information

Part Number	Description	Package Type
VL151 (A3)-3	VL151 Tape and Reel (3K)	DFN-10 (3x3mm)
VL151 (A3)-2	VL151 Tape and Reel (3K)	DFN-8 (2x3mm)
VL151 (A3)-W	VL151 Tape and Reel (3K)	WLCSP-6 (1.2x1.25mm)

ALL CONFIDENTIAL

Tape and Reel Information

Reel Dimensions

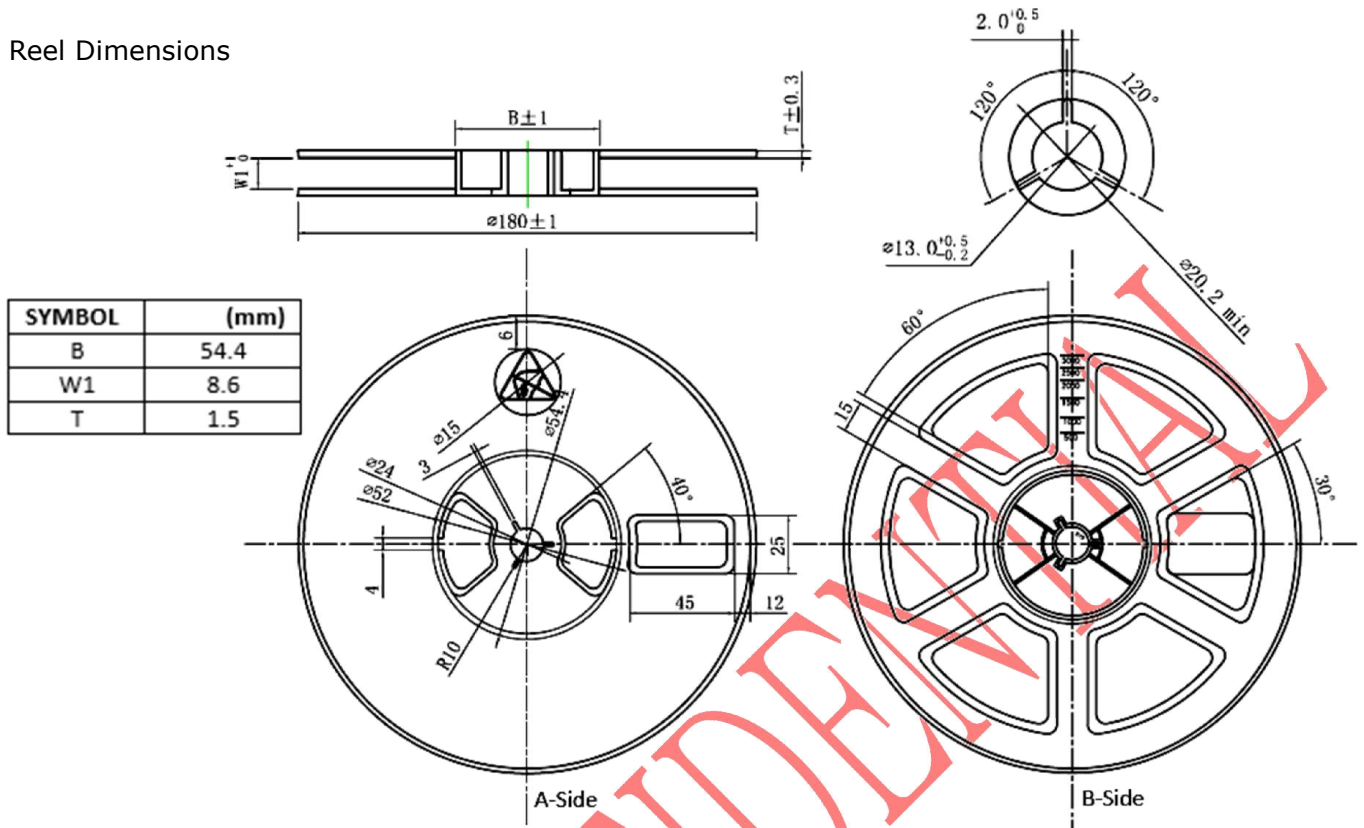

Type Dimensions

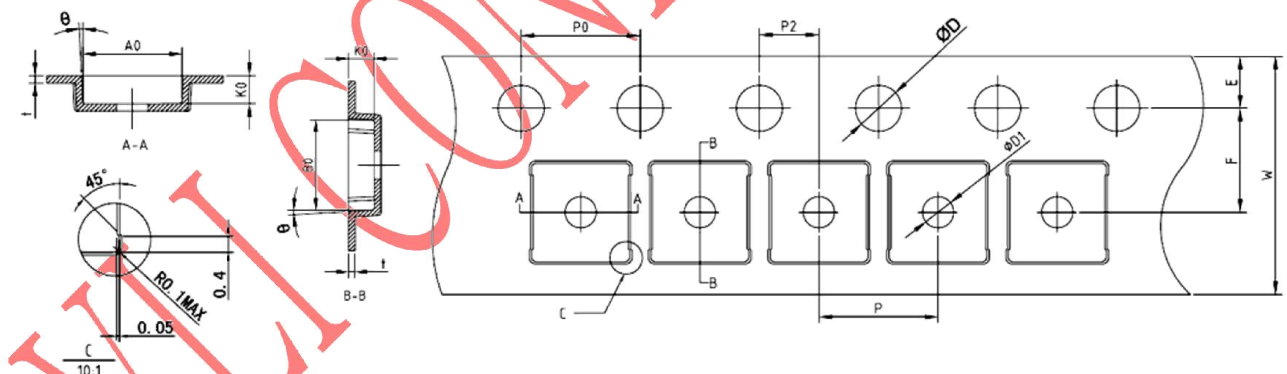

SYMBOL	(mm)
E	1.75±0.10
F	3.50±0.05
P2	2.00±0.05
D	1.55±0.05
D1	1.05 ^{+0.25} ₀
P0	4.00±0.10
10P0	40.00±0.20

SYMBOL	(mm)
W	8.00 ^{+0.30} _{-0.10}
P	4.00±0.10
A0	3.25±0.10
B0	3.25±0.10
K0	0.95±0.10
t	0.25±0.02
θ	3° TYP

Figure 10 - Tape & Reel Information

CONFIDENTIAL

VIA Labs, Inc.

www.via-labs.com

7F, 529-1, Zhongzheng Rd.,
Xindian District, New Taipei City 23148 Taiwan

Tel: (886-2) 2218-1838

Fax: (886-2) 2218-2553

Email: sales@via-labs.com.tw

Copyright © 2016 VIA Labs, Inc. All Rights Reserved.

No part of this document may be reproduced, transmitted, transcribed, stored in a retrieval system, or translated into any language, in any form or by any means, electronic, mechanical, magnetic, optical, chemical, manual or otherwise without the prior written permission of VIA Labs, Inc. The material in this document is for information only and is subject to change without notice. VIA Labs, Inc. reserves the right to make changes in the product design without reservation and without notice to its users.

All trademarks are the properties of their respective owners.

No license is granted, implied or otherwise, under any patent or patent rights of VIA Labs, Inc. VIA Labs, Inc. makes no warranties, implied or otherwise, in regard to this document and to the products described in this document. The information provided by this document is believed to be accurate and reliable as of the publication date of this document. However, VIA Labs, Inc. assumes no responsibility for any errors in this document. Furthermore, VIA Labs, Inc. assumes no responsibility for the use or misuse of the information in this document and for any patent infringements that may arise from the use of this document. The information and product specifications within this document are subject to change at any time, without notice and without obligation to notify any person of such change.

X-ON Electronics

Largest Supplier of Electrical and Electronic Components

Click to view similar products for [USB Interface IC](#) category:

Click to view products by [VIA manufacturer](#):

Other Similar products are found below :

[CYUSB2304-68LTXI](#) [CYPD2120-24LQXI](#) [CYUSB3014-BZXCT](#) [CYWB0164BB-BZXI](#) [CYWB0224ABS-BZXI](#) [CP2102NP1174GM](#)
[CYPD2119-24LQXIT](#) [CY7C65621-56LTXIT](#) [CY7C65631-56LTXIT](#) [DPO2039DABQ-13](#) [CYPD5225-96BZXIT](#) [UPD720201K8-711-BAC-A](#)
[CYPD5235-96BZXIT](#) [CYPD3196-24LDXS](#) [UPD720115K8-611-BAK-A](#) [UPD720115K8-711-BAK-A](#) [UPD720211K8-711-BAL-A](#)
[PI2DPX1217XUAEX](#) [UPD720211K8-611-BAL-A](#) [CY7C65223D-32LTXI](#) [CYPD6127-48LQXIT](#) [WUSB3801Q-12/TR](#) [FT232BL-JSM](#)
[PL2303GC](#) [PL2586](#) [VL152-WLCSP](#) [CH344Q](#) [USB5744B-I/2GX01](#) [TPS25830AQCWRHBRQ1](#) [TUSB544IRNQR](#) [FP6606ACDW4](#)
[CH334U](#) [CH9101U](#) [CH9101N](#) [CH334S](#) [ISOUSB211DPR](#) [TUSB211AIRWBR](#) [TPS25730SRSMR](#) [TUSB1210BRHBTQ1](#) [TUSB213IRGYT](#)
[TUSB213RGYT](#) [TUSB214RWBT](#) [TUSB4020BIPHRQ1](#) [USB2517I-JZX-TR](#) [USB3318-CP](#) [USB3343-CP](#) [USB3503T-I/ML](#) [USB4624I-](#)
[1080HN](#) [STUSB1602AQTR](#) [TUSB214IRWBT](#)