

**VICOR CONFIDENTIAL**

THIS DOCUMENT AND THE DATA DISCLOSED HEREIN OR HEREWITH IS NOT TO BE REPRODUCED, USED, OR DISCLOSED IN WHOLE OR IN PART TO ANYONE WITHOUT PERMISSION OF VICOR CORP.

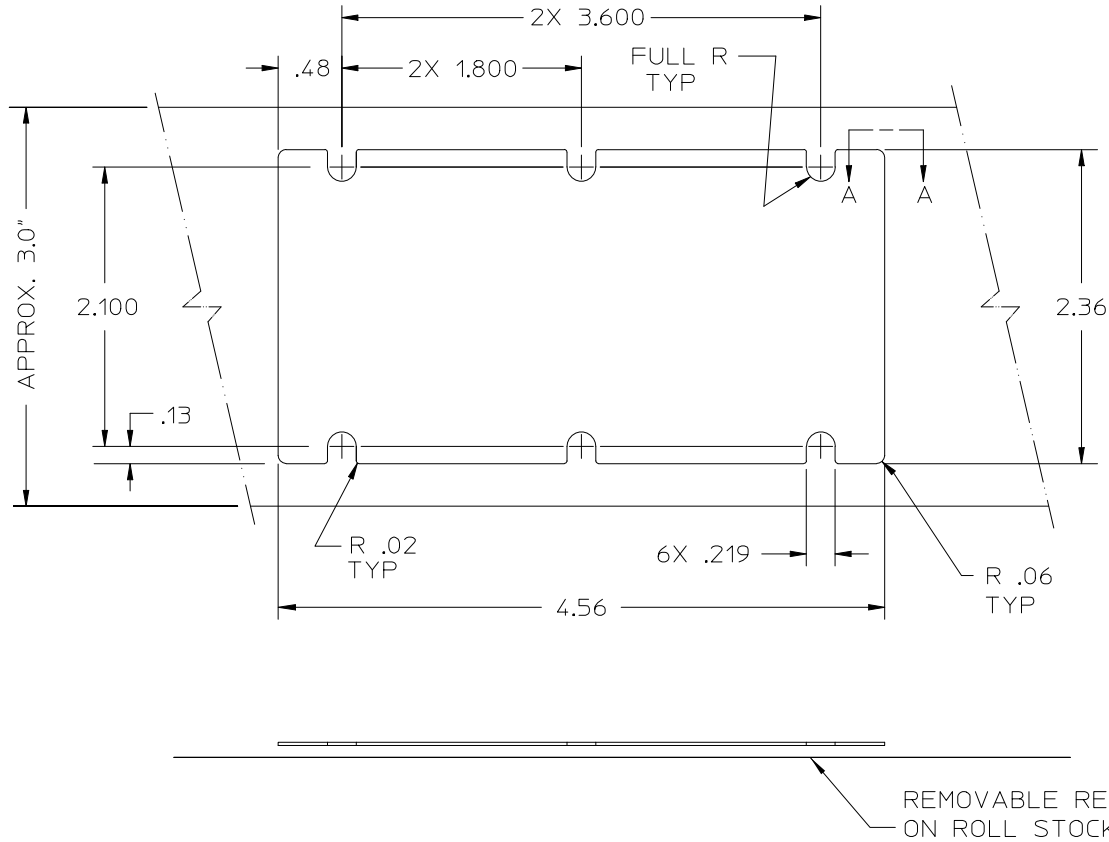

REV.	DESCRIPTION	DATE	APPROVED
A	RELEASED PER ECO #939	SPV 3/10/87	WRH
B	REVISED PER ECO #1319	SPV 3/25/88	WRH
C	REV & REDRWN PER E940079	GJL 4/4/94	DPK
D	REVISED PER E940338	RCM 5/27/94	DPK
E	REVISED PER E940668	RCM 9/21/94	DPK
F	REVISED PER E960284	DPK 7/1/96	RCM
H	REVISED PER E980291	RCM 7/7/98	DPK
J	REVISED PER E040083	DPK 03/30/04	PT

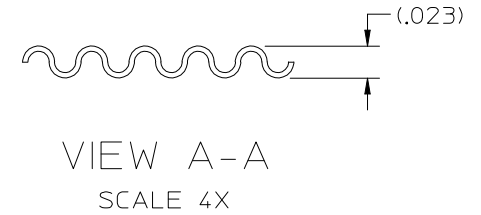

**NOTES:**

1. MATERIAL:  
.010 THK GRAPHITE PAD, WITH DOUBLE COATED POLYESTER FILM APPLIED TO ONE SIDE; DOUBLE COATED FILM TO BE COMPRISED OF A .0005 THK CARRIER WITH .00125 THK ACRYLIC ADHESIVE ON GRAPHITE PAD AND LINER SIDE
2. PROVIDE PARTS ON A "KISS CUT" ROLL.

DRAWN BY <i>S. VISCONTI</i>		DATE <i>3/88</i>			
<small>UNLESS OTHERWISE SPECIFIED DIMENSIONS ARE IN INCHES-- TOLERANCES ARE: FRACTIONS DECIMALS ANGLES ±1/64 .XX= .01 ±1° .XXX=+.005</small>					
THIRD ANGLE PROJECTION 		SIZE <b>B</b>	FSCM NO. <b>67131</b>	DWG NO. <b>01777</b>	REV <b>J</b>
DO NOT SCALE DRAWING		SCALE FULL	SHEET 1 OF 1		

## X-ON Electronics

Largest Supplier of Electrical and Electronic Components

*Click to view similar products for [Thermal Interface Products](#) category:*

*Click to view products by [Vicor](#) manufacturer:*

Other Similar products are found below :

[7721-9PPS](#) [FGN80-2](#) [PFM-172-60](#) [A-40](#) [174-9-230P](#) [9601-7](#) [5300AC](#) [1.500G](#) [08133](#) [V6622C](#) [TVQF-1225-07S](#) [TP0001](#) [4860](#) [SC80-W2](#)  
[V6516C](#) [A17713-06](#) [A17713-05](#) [A17690-06](#) [A17775-03](#) [A17690-05](#) [A17690-03](#) [A17653-02](#) [A17689-02](#) [A17690-04](#) [A17775-05](#) [A17775-](#)  
[06](#) [A17690-08](#) [A17690-02](#) [A17689-06](#) [A17653-06](#) [A17690-12](#) [A17653-03](#) [A17536-02](#) [A17689-03](#) [A17536-10](#) [A17752-13](#) [A17752-04](#)  
[A17752-07](#) [A17634-12](#) [19-36565-0001-1](#) [A17752-09](#) [22000-001A](#) [A17752-20](#) [A17752-16](#) [A17752-12](#) [A17653-04](#) [A17634-10](#) [A17634-09](#)  
[A17634-07](#) [A17633-20](#) [A17633-07](#)