

VICOR CONFIDENTIAL  
 THIS DOCUMENT AND THE DATA DISCLOSED HEREIN OR  
 HEREWITH IS NOT TO BE REPRODUCED, USED OR  
 DISCLOSED IN WHOLE OR IN PART TO ANYONE WITHOUT  
 THE PERMISSION OF VICOR CORP.

REV.	DESCRIPTION	DATE	APPROVED
4	RELEASED PER E090033	AR 01/09/09	REJH
5	REVISED PER E091548	JS 11/16/09	REJH
6	REDRAWN PER E100871	DCS 06/23/10	KUK
7	REVISED PER E111266	VSS 12/22/11	REJH

F

E

D

C

B

A

#4-40 UNC-2B COLD FORM TAP  
 .140 DP MIN. FROM FAR SIDE  
 DO NOT BREAK THRU  
 (6) PL.

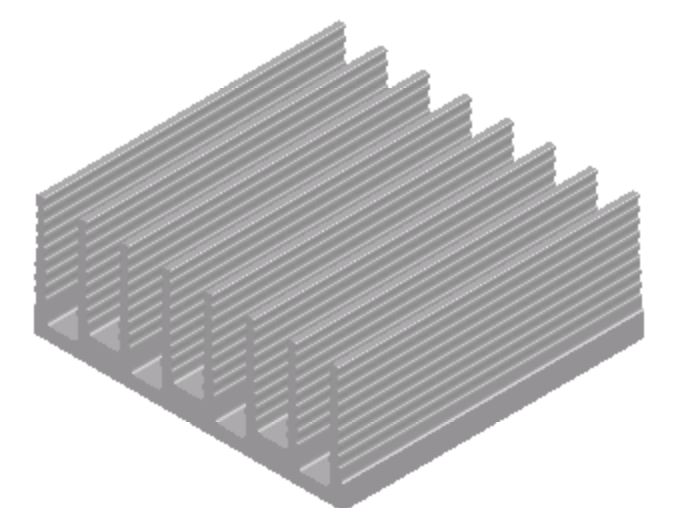
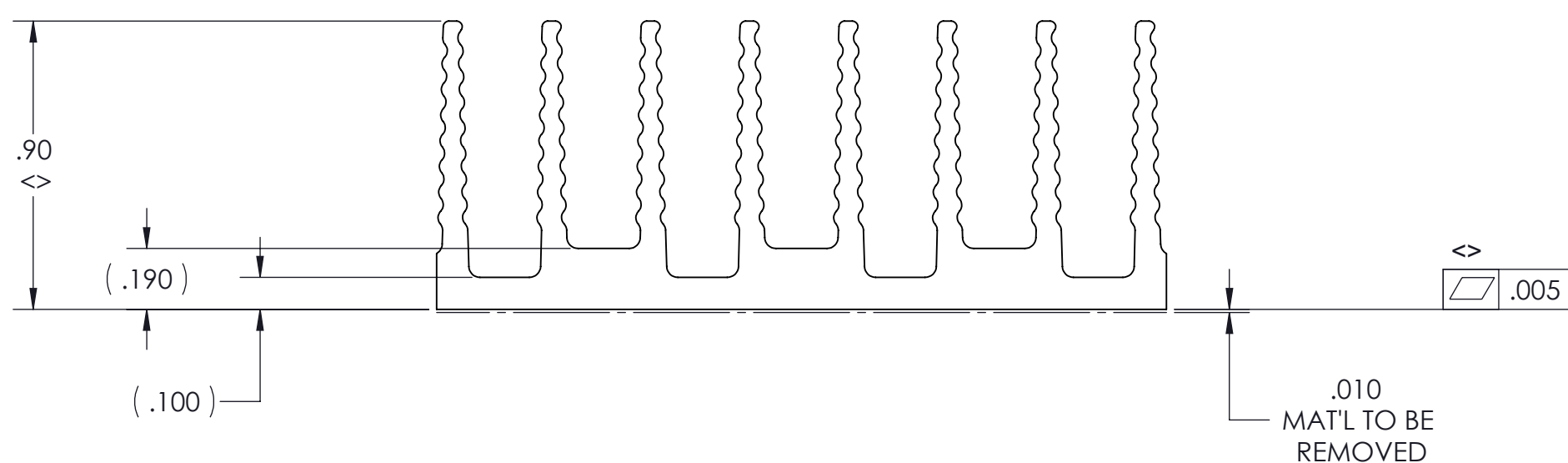
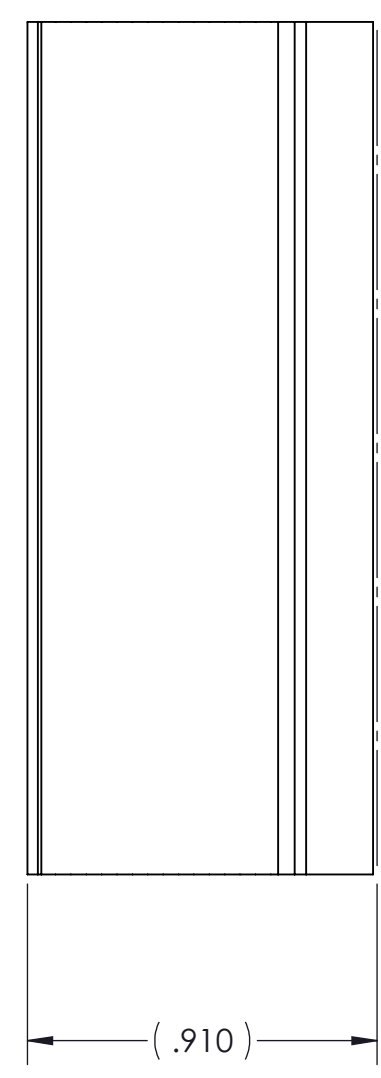
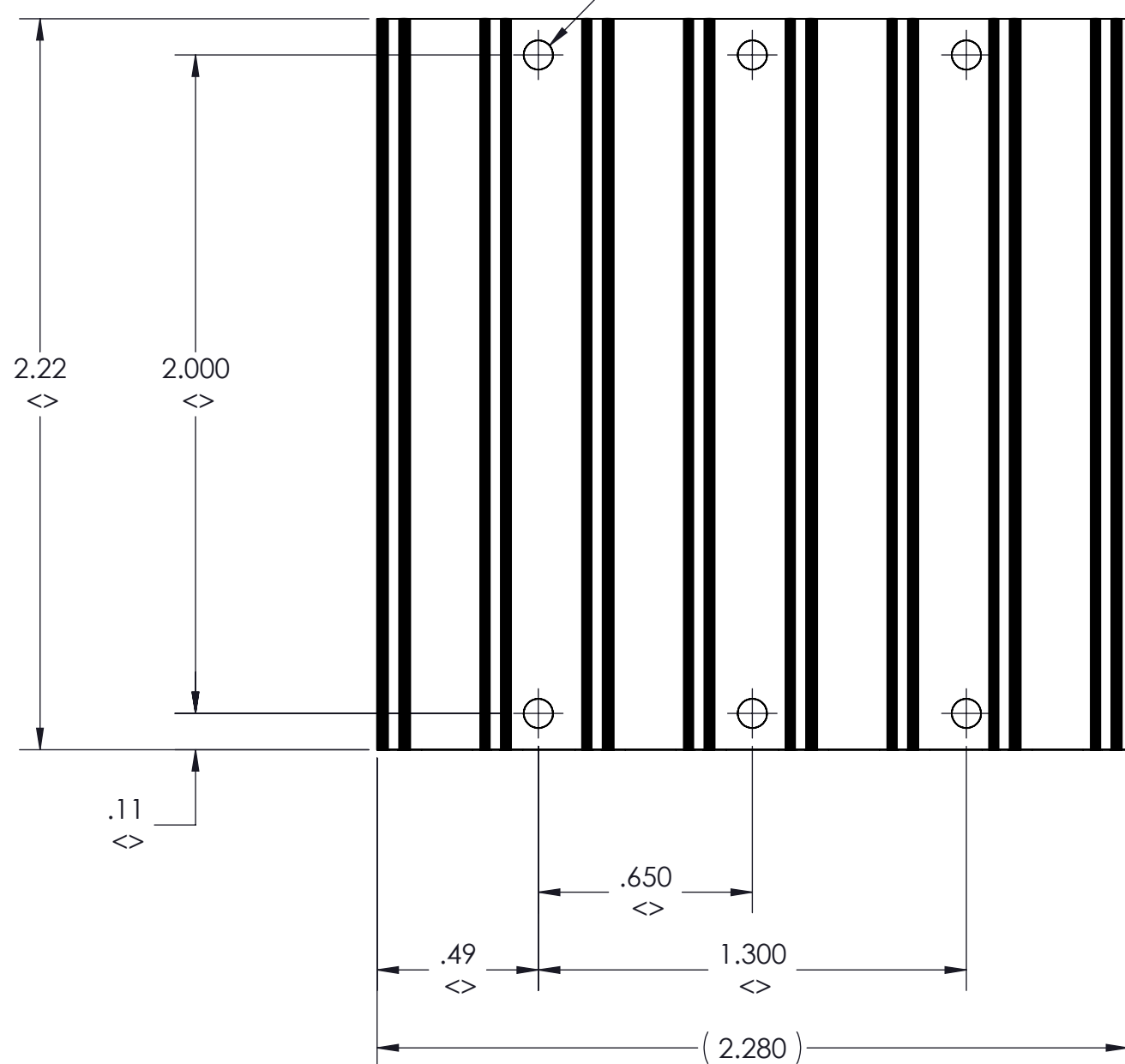

NOTES:

1. MATERIAL: EXTRUSION SEE SHEET 2 OF 2
2. REMOVE ALL BURRS AND SHARP EDGES.
3. CLEAR FINISH, RoHS COMPLAINT PER CST-0001, LATEST REVISION PER A)CHROMIUM FREE, OR B)TRIVALENT CHROMIUM IN ACCORDANCE WITH MIL-DTL-5541, TYPE II, CLASS 1A OR 3. SEE CST-0003 FOR TYPES OF AVAILABLE FINISHES.
4. "<>" DENOTES CRITICAL CHARACTERISTIC FOR LOT INSPECTION.
5. DIMENSIONS ARE INCHES ONLY.

DRAWN BY David Schmidt	DATE 06/23/2010	SWD		
UNLESS OTHERWISE SPECIFIED DIMENSIONS ARE : INCH / (MM)		<b>HTSNK, "B" X-FLOW, .9H, LOW FLOW, THREADED</b>		
TOLERANCES ARE: DECIMALS ±0.01 (0.25) X.XX [X.X] ±0.01 (0.25) X.XXX [X.XX] ±0.005 (0.127)		ANGLE ±1°	SIZE <b>C</b>	CAGE CODE <b>67131</b>
THIRD ANGLE PROJECTION  DO NOT SCALE DRAWING		DWG NO <b>30269</b>	REV <b>7</b>	SCALE 2:1
			SHEET 1 OF 2	

VICOR CONFIDENTIAL  
THIS DOCUMENT AND THE DATA DISCLOSED HEREIN OR  
HEREWITH IS NOT TO BE REPRODUCED, USED OR  
DISCLOSED IN WHOLE OR IN PART TO ANYONE WITHOUT  
THE PERMISSION OF VICOR CORP.

REV.	DESCRIPTION	DATE	APPROVED
	SEE SHEET 1 OF 2		

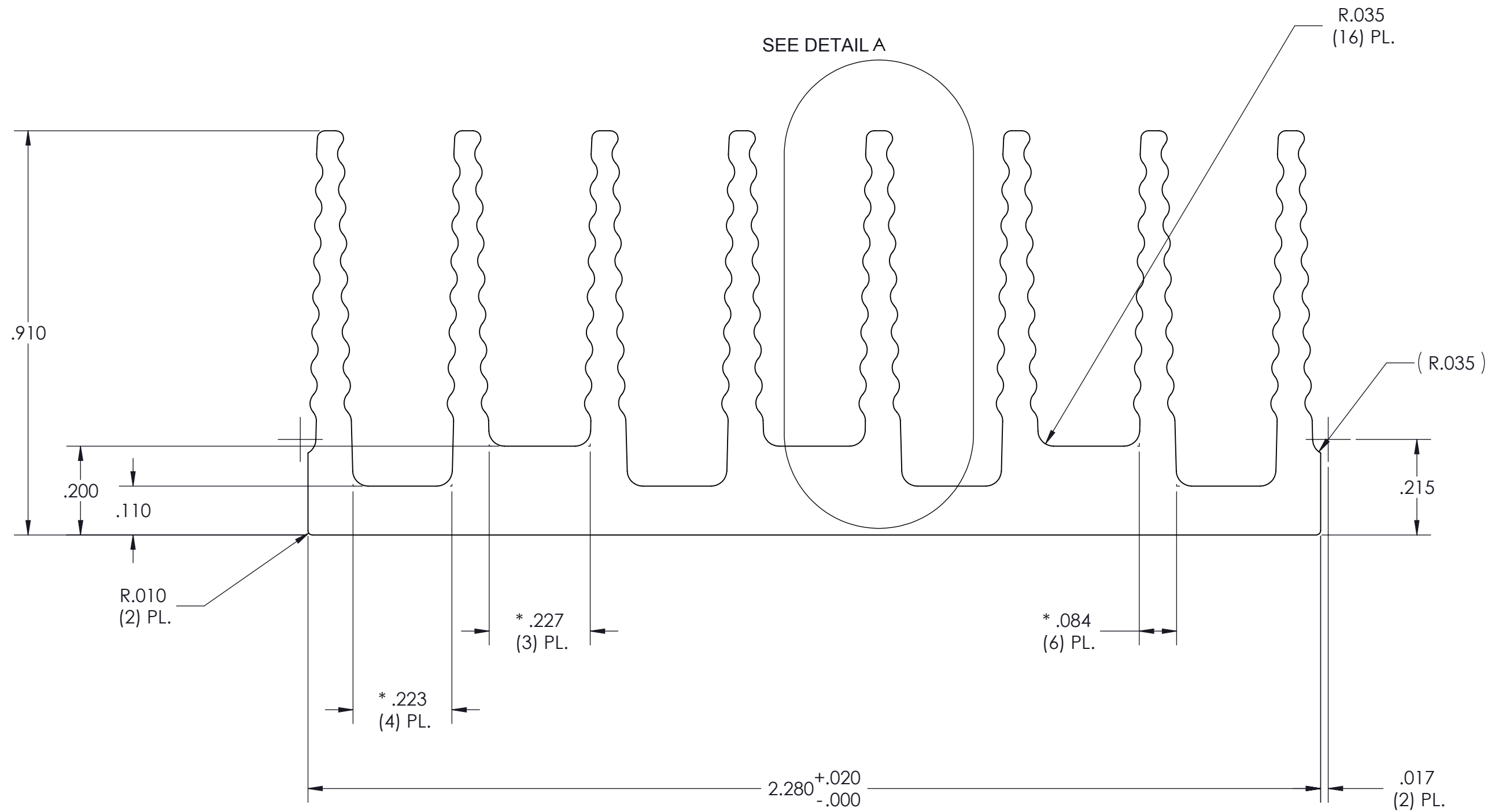

PROFILE COMMON FOR
30270
30724
30269
30725

- NOTES:
- MATL: ALUMINUM 6063-T5
  - \* DENOTES DIMENSION TO THEORETICAL SHARP CORNER.
  - ALL DIMENSIONS ARE CRITICAL CHARACTERISTICS.
  - RoHS COMPLIANT PER CST-0001 LATEST REVISION.
  - WORKMANSHIP STANDARDS WS-0004, WS-0006 AND WS-0007 APPLY TO THIS PART.
  - DIMENSIONS ARE INCHES ONLY.

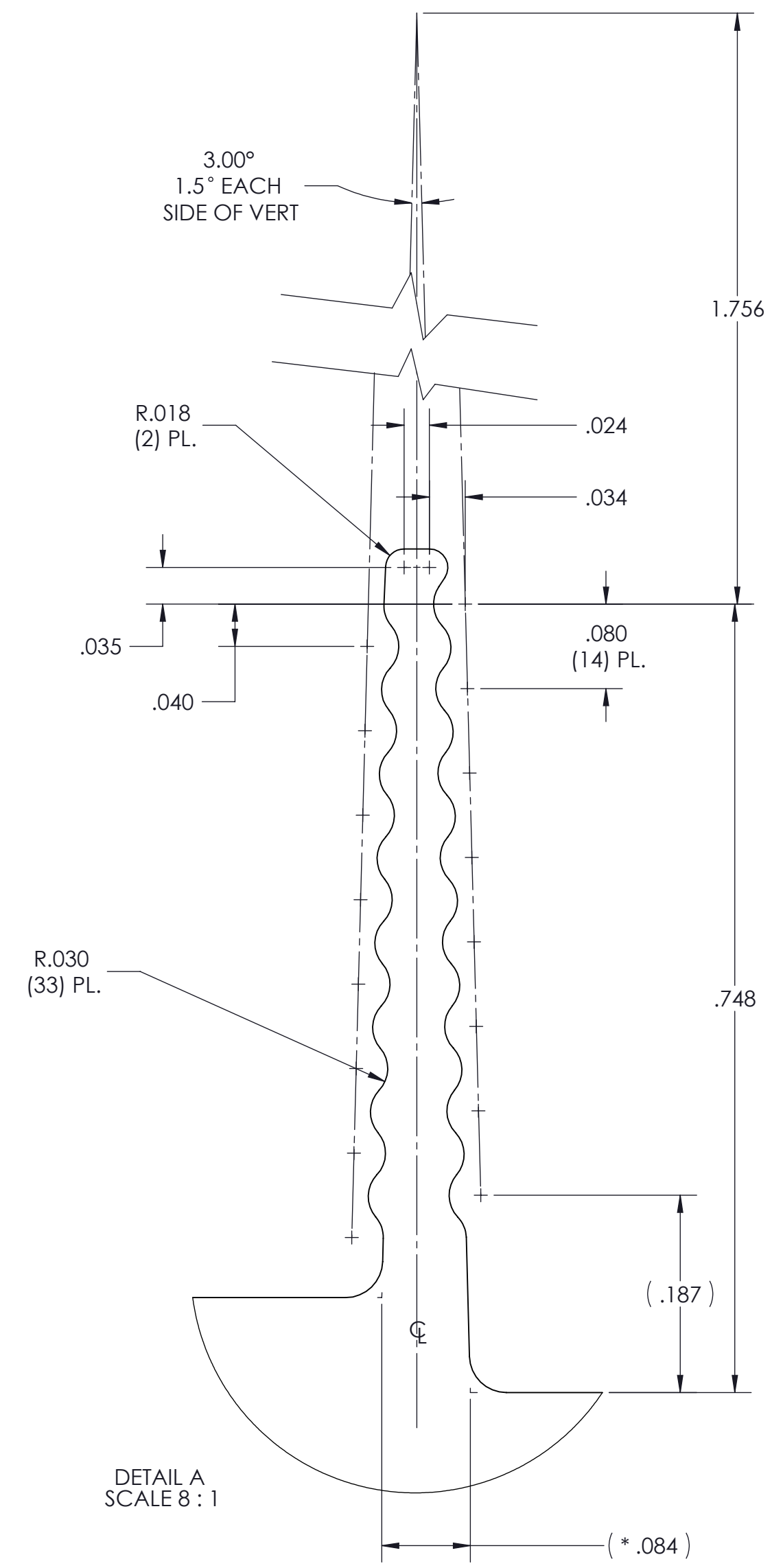

DRAWN BY David Schmidt	DATE 06/23/2010	SWD	
UNLESS OTHERWISE SPECIFIED DIMENSIONS ARE : INCH / (MM)		<b>HTSNK, "B" X-FLOW, .9H, LOW FLOW, THREADED</b>	
TOLERANCES ARE: DECIMALS                      ANGLES X.XX [X.X] = ±0.01 [0.25]                      ±1° X.XXX [X.XX] = ±0.005 [0.127]			
THIRD ANGLE PROJECTION 	SIZE <b>C</b>	CAGE CODE <b>67131</b>	DWG NO <b>30269</b>
DO NOT SCALE DRAWING	SCALE 2:1		REV <b>7</b>
		SHEET 2 OF 2	

## X-ON Electronics

Largest Supplier of Electrical and Electronic Components

*Click to view similar products for [Thermal Interface Products](#) category:*

*Click to view products by [Vicor](#) manufacturer:*

Other Similar products are found below :

[7721-9PPS](#) [FGN80-2](#) [PFM-172-60](#) [A-40](#) [174-9-230P](#) [9601-7](#) [5300AC](#) [1.500G](#) [08133](#) [V6622C](#) [TVQF-1225-07S](#) [TP0001](#) [4860](#) [SC80-W2](#)  
[V6516C](#) [A17536-04](#) [A17713-06](#) [A17713-05](#) [A17653-05](#) [A17690-06](#) [A17689-04](#) [A17775-03](#) [A17690-05](#) [A17653-02](#) [A17689-02](#) [A17690-04](#) [A17775-05](#) [A17775-06](#) [A17690-08](#) [A17690-02](#) [A17689-06](#) [A17653-06](#) [A17690-12](#) [A17653-03](#) [A17536-02](#) [A17689-03](#) [A17536-10](#)  
[A17752-13](#) [A17752-04](#) [A17752-07](#) [A17634-12](#) [19-36565-0001-1](#) [A17752-09](#) [22000-001A](#) [A17752-20](#) [A17752-16](#) [A17752-12](#) [A17653-04](#)  
[A17634-10](#) [A17634-09](#) [A17634-07](#)