

THIS DOCUMENT AND THE DATA DISCLOSED HEREIN OR HEREWITH IS NOT TO BE REPRODUCED, USED OR DISCLOSED IN WHOLE OR IN PART TO ANYONE WITHOUT THE PERMISSION OF VICOR CORP.

REV	DESCRIPTION	DATE	APPROVED
1	RELEASED PER E063557	01/11/06	ECF
2	REVISED PER E063557	07/14/09	REJH
3	REDRAWN PER E100887	6/11/10	KUK

#4-40 UNC-2B COLD FORM TAP
 .140 DP MIN. FROM FAR SIDE
 DO NOT BREAK THRU
 (6) PL.

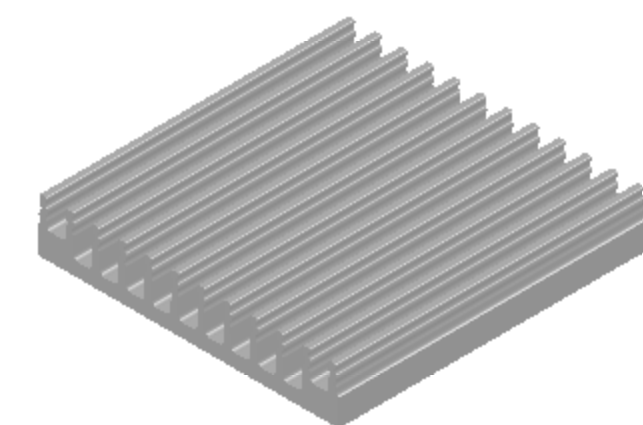
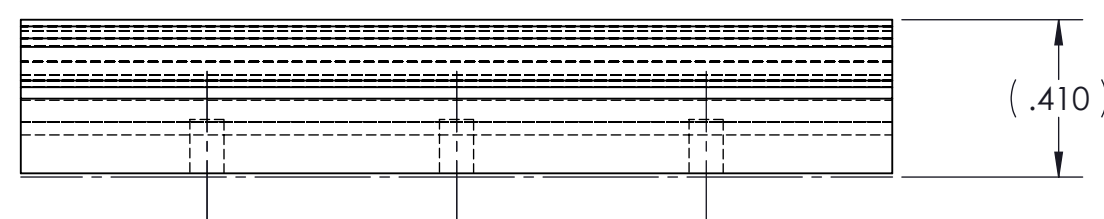
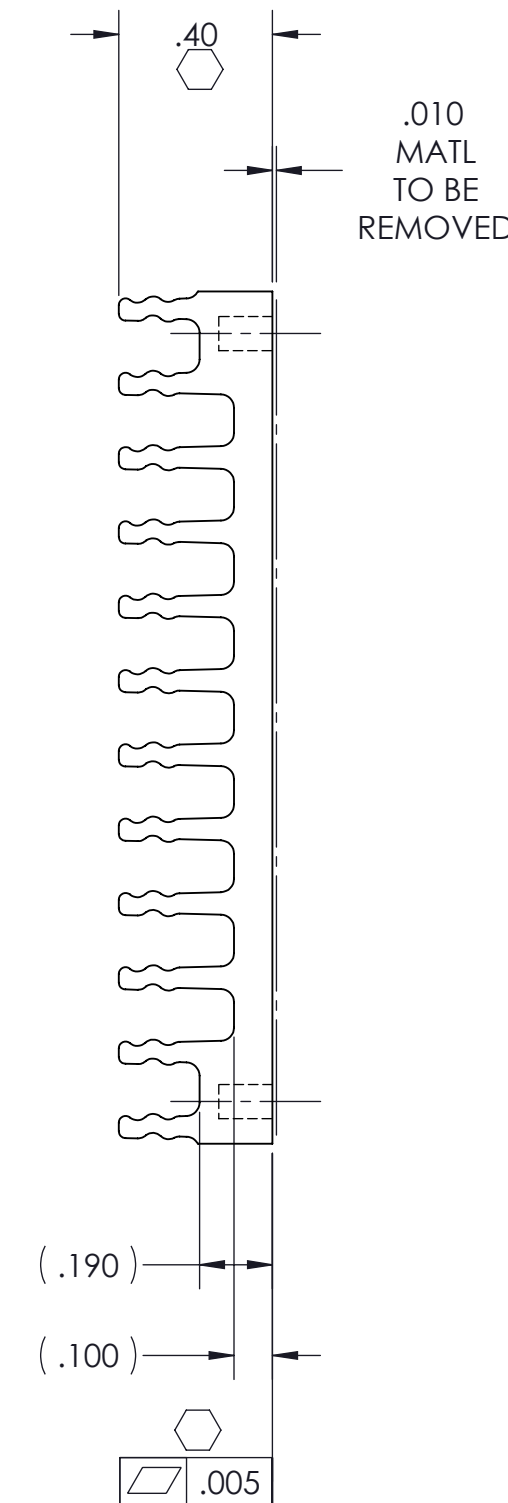
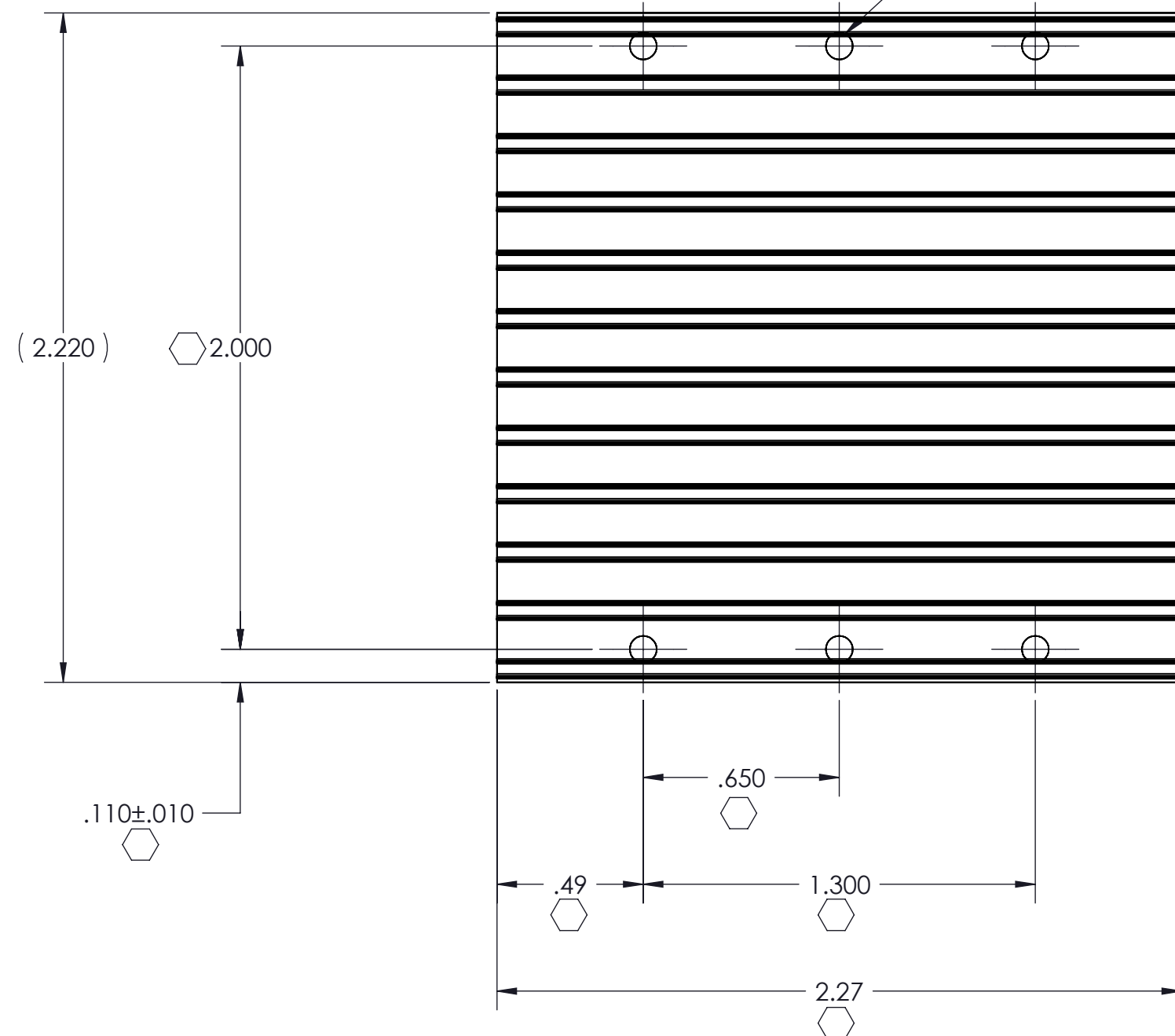

NOTES:

1. MATERIAL: EXTRUSION SEE SHEET 2 OF 2
2. REMOVE ALL BURRS AND SHARP EDGES
3. CLEAR FINISH, RoHS COMPLIANT, CHROMIUM FREE PER CST-0001 LATEST REVISION.
4. "⬡" DENOTES CRITICAL CHARACTERISTIC FOR LOT INSPECTION.
5. DIMENSIONS ARE INCHES ONLY

DRAWN	DATE				
P.E. IENI	12/15/05				
MATERIAL	UNLESS OTHERWISE SPECIFIED DIMENSIONS ARE INCH [MM]	HTSNK 'B' LONG .4H LOW FLOW, THREADED			
SEE NOTES	TOLERANCES ARE: DECIMALS ANGLES X.XX [X.X] = ±0.01 [0.25] ±1° X.XXX [X.XX] = ±0.005 [0.127]				
FINISH	THIRD ANGLE PROJECTION	SIZE	CAGE CODE	DWG NO	REV
SEE NOTES		C	67131	32188	3
		SCALE 2 : 1		SHEET 1 OF 2	

VICOR CONFIDENTIAL

THIS DOCUMENT AND THE DATA DISCLOSED HEREIN OR HEREWITH IS NOT TO BE REPRODUCED, USED OR DISCLOSED IN WHOLE OR IN PART TO ANYONE WITHOUT THE PERMISSION OF VICOR CORP.

REVISIONS

REV	DESCRIPTION	DATE	APPROVED
	SEE SHEET 1 OF 2		

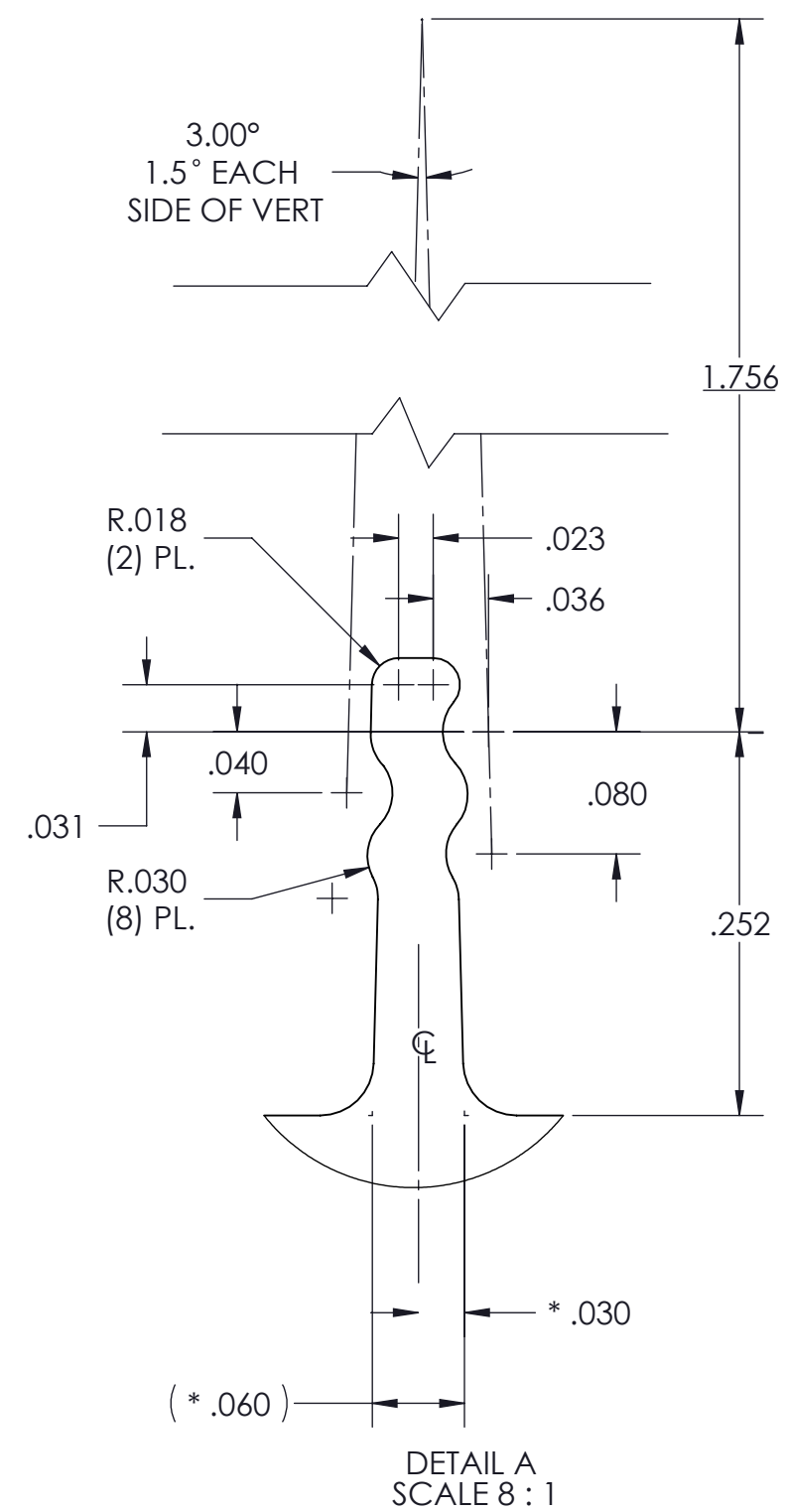
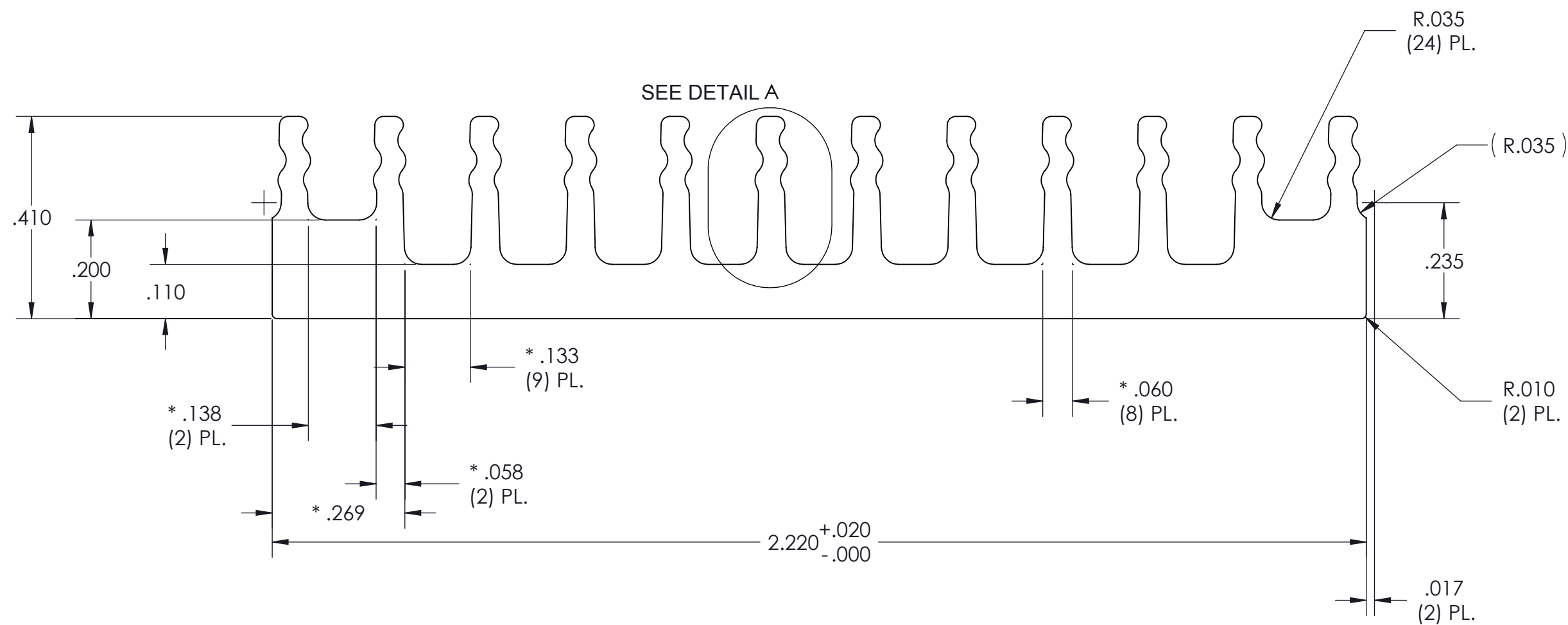

PROFILE COMMON FOR
30195
30718
32188
30482

NOTES:

- MATL: ALUMINUM 6063-T5
- * DENOTES DIMENSION TO THEORETICAL SHARP CORNER.
- ALL DIMENSIONS ARE CRITICAL CHARACTERISTICS
- RoHS COMPLIANT PER CST-0001 LATEST REVISION.
- DIMENSIONS ARE INCHES ONLY

DRAWN A. RAGIPANI	DATE 07/14/09	SWD		
MATERIAL SEE NOTES		UNLESS OTHERWISE SPECIFIED DIMENSIONS ARE INCH [MM] TOLERANCES ARE: DECIMALS ANGLES X.XX [X.X] = ±0.01 [0.25] ±1° X.XXX [X.XX] = ±0.005 [0.127]		
FINISH SEE NOTES		THIRD ANGLE PROJECTION 	SIZE C	CAGE CODE 67131
		DO NOT SCALE DRAWING	DWG NO 32188	REV 3
			SCALE 4 : 1	SHEET 2 OF 2

X-ON Electronics

Largest Supplier of Electrical and Electronic Components

Click to view similar products for [Heat Sinks](#) category:

Click to view products by [Vicor](#) manufacturer:

Other Similar products are found below :

[657-20ABPNE](#) [73452PPBA](#) [A22-4026](#) [120-1873-007](#) [218-40CTE3](#) [231-69PAB-15V](#) [231-75PAB-13V](#) [231-75PAB-15V](#) [253-122ABE-22](#)
[PSC22CB](#) [295-2](#) [CLP212SG](#) [D10100-28](#) [BDN183CBA01](#) [3-21053-4](#) [TX0506-1B](#) [LAE66A3CB](#) [511-3U](#) [73381PPBA](#) [73403PPBA](#) [8191-](#)
[E40](#) [510-12M](#) [529802B00000](#) [D10650-40T5](#) [6225B-MT6G](#) [ATS-54310K-C2-R0](#) [648-51AB](#) [657-20ABPESC](#) [679-25AG](#) [FK 212 CB SA](#)
[FK225 SA L1](#) [241404B91203G](#) [6801G](#) [680-5K](#) [7106DG/TR](#) [SK145 37 5STSTO220](#) [7109DG/TR](#) [TS-11042-CY](#) [S14K35G3S5](#) [8924G](#)
[7717-133DAP](#) [7717-26DAP](#) [4509](#) [SW25-4G](#) [CLP-215](#) [CLP-207](#) [D20850-40-T2](#) [APF30-30-10CB/A01](#) [V8508E](#) [268-85CTE](#)