

VICOR CONFIDENTIAL  
 THIS DOCUMENT AND THE DATA DISCLOSED HEREIN OR  
 HEREIN IS NOT TO BE REPRODUCED, USED OR  
 DISCLOSED IN WHOLE OR IN PART TO ANYONE WITHOUT  
 THE PERMISSION OF VICOR CORP.

REV.	DESCRIPTION	DATE	APPROVED
1	RELEASED PER E120943	GCK 10/22/12	REJH
2	REVISED PER E130143	GCK 02/01/13	REJH

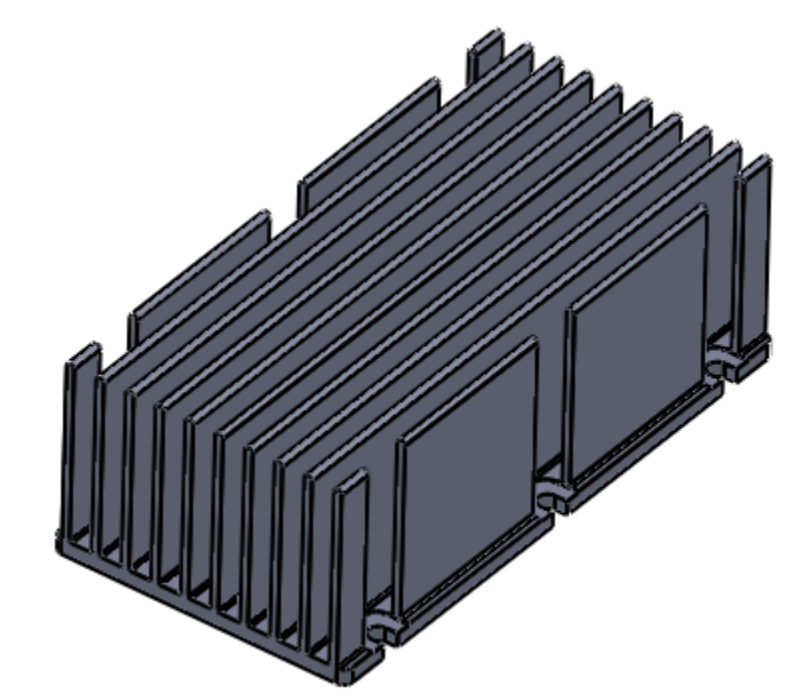
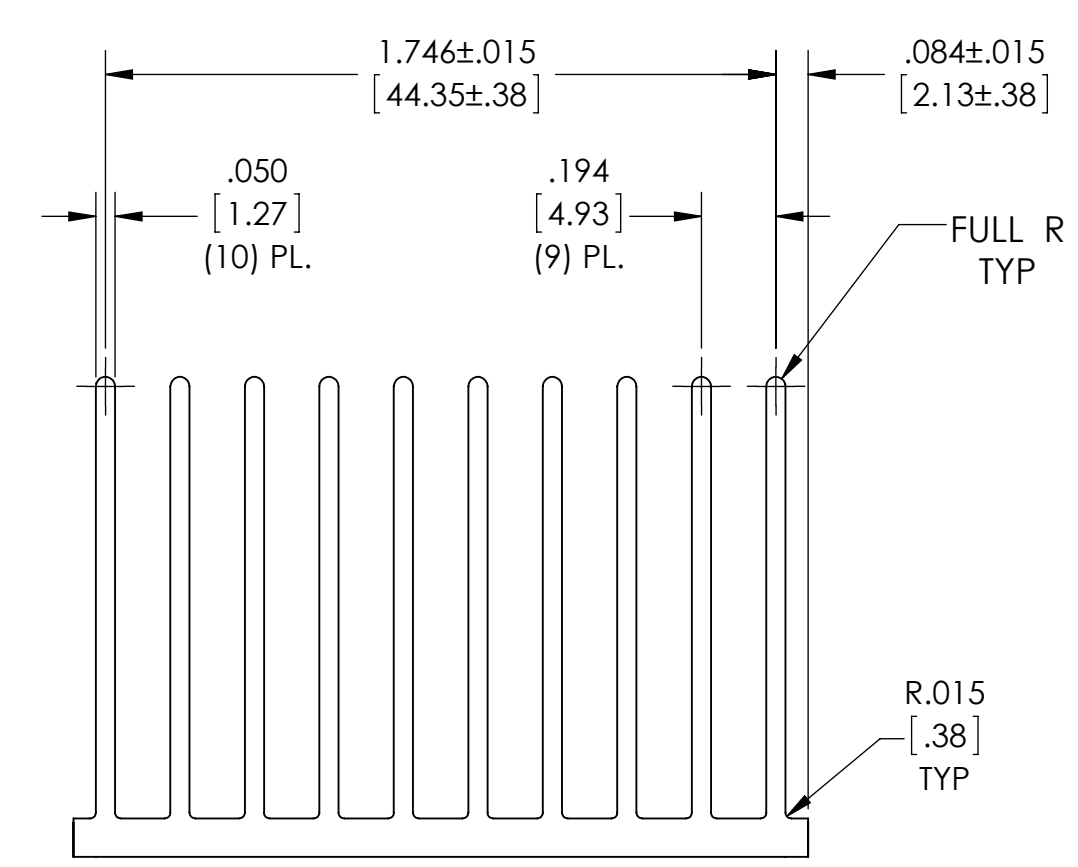
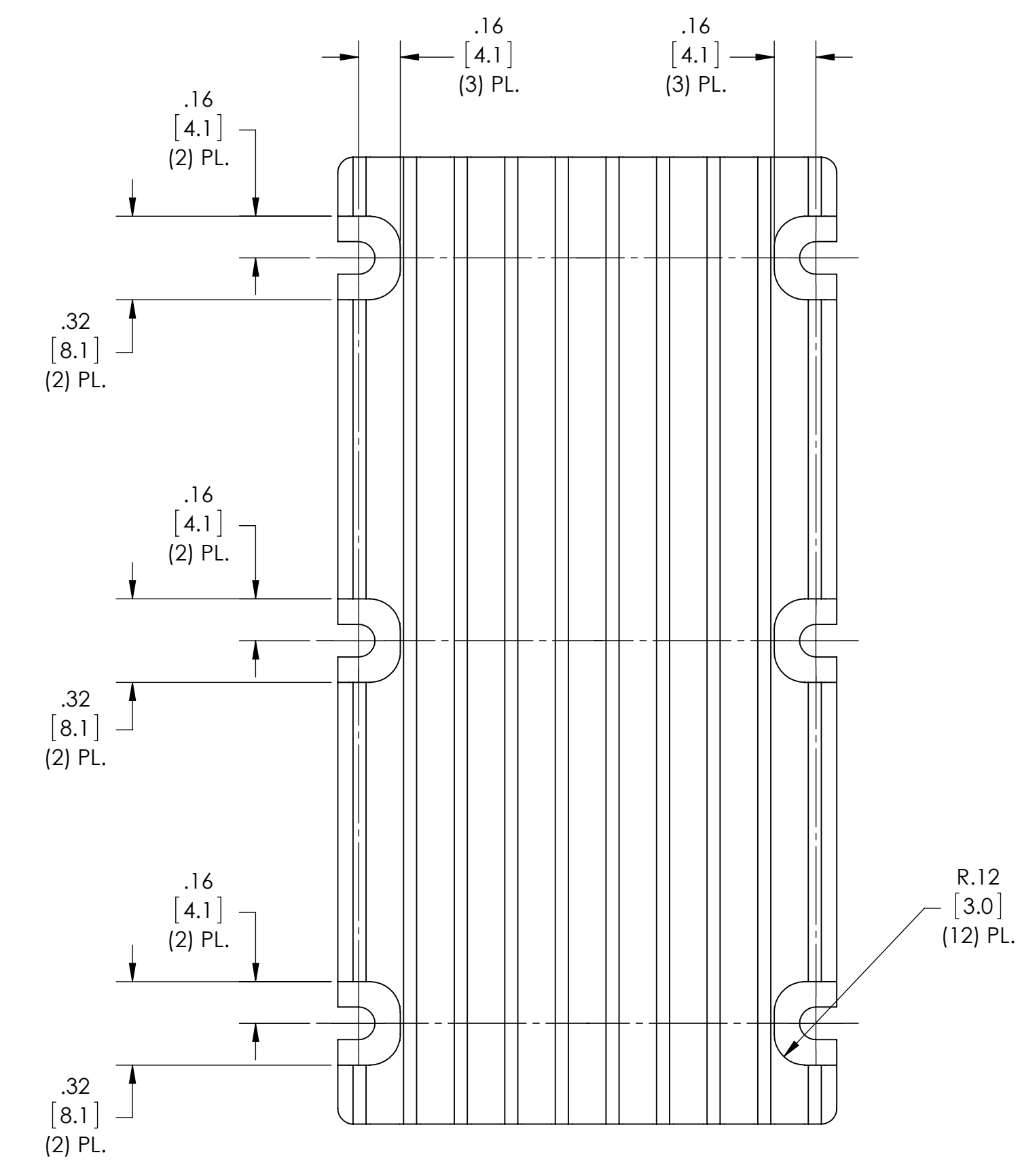
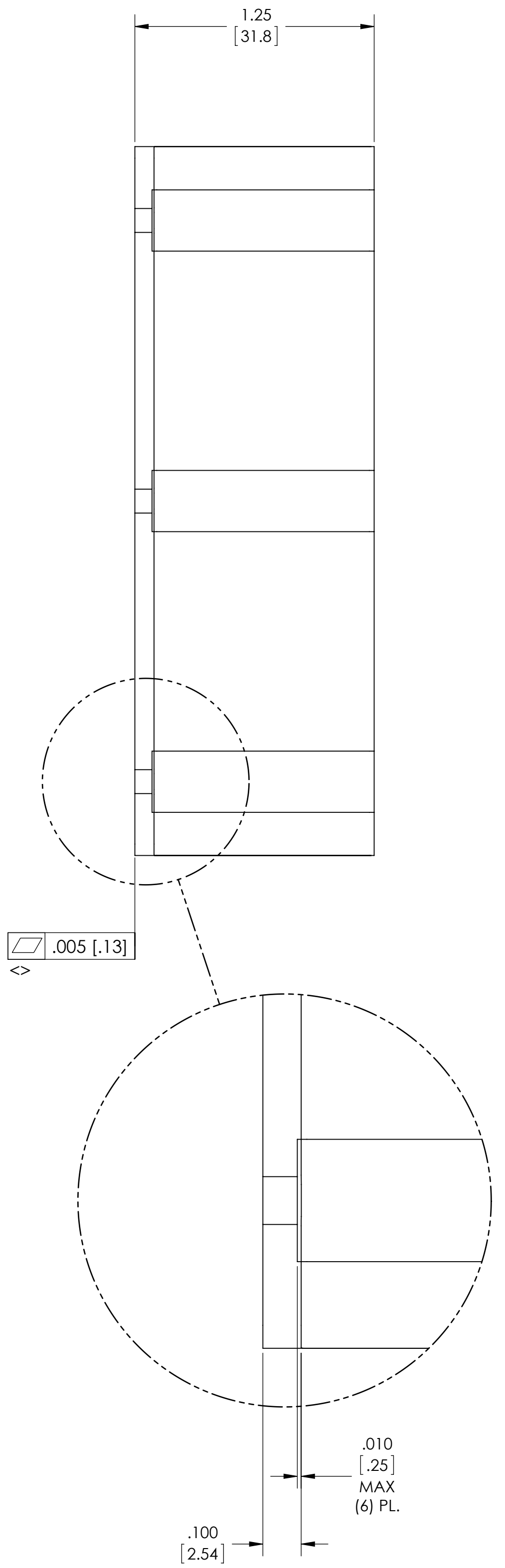
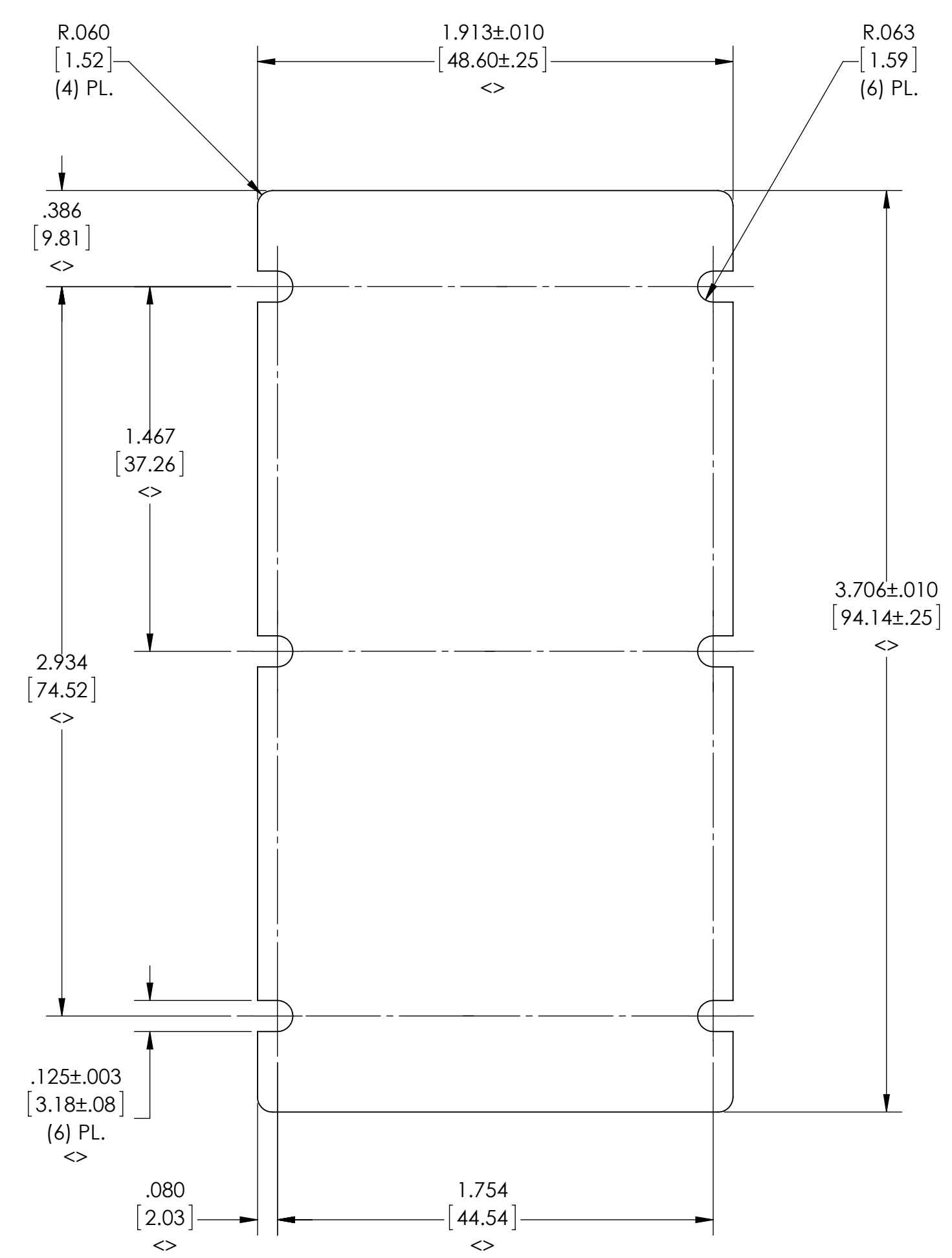

- NOTES:
- 1- MATL: ALUMINUM 6063-T5.
  - 2- CORNERS SHOWN SHARP TO BE .005/[.13] MAX.
  - 3- CLEAR FINISH, RoHS COMPLIANT PER CST-0001, LATEST REVISION PER  
 A.) CHROMIUM FREE, OR  
 B.) TRIVALENT CHROMIUM IN ACCORDANCE WITH MIL-DTL-5541, TYPE II, CLASS 1A OR 3.  
 SEE CST-0003 FOR TYPES OF AVAILABLE FINISHES.
  - 4- ALL DIMENSIONS APPLY AFTER PLATING.
  - 5- <> DENOTES CRITICAL CHARACTERISTIC FOR LOT INSPECTION.
  - 6- MAXIMUM STEP BETWEEN ADJOINING CUTTER PASSES TO BE .0005/[.013]
  - 7- BASE PLATE SURFACE PREPARATION PRIOR TO CLEAR FINISH IN ACCORDANCE WITH WS-0016.
  - 8- REMOVE ALL BURRS AND SHARPE EDGES.

DRAWN BY R.E.J Hickey	DATE 12/15/11	<b>VICOR</b> <small>SWD</small>	
UNLESS OTHERWISE SPECIFIED DIMENSIONS ARE: INCH / [MM]		<b>HEATSINK VIBrick L-FLOW 1.25</b>	
TOLERANCES ARE: DECIMALS ANGLES X.XX [X.X] = +0.01 [0.25] ±1° X.XXX [X.XX] = ±0.005 [0.127]		SIZE <b>D</b>	CAGE CODE <b>67131</b>
THIRD ANGLE PROJECTION 		DWG NO <b>38145</b>	REV <b>2</b>
DO NOT SCALE DRAWING		SCALE 2:1	SHEET 1 OF 1

## X-ON Electronics

Largest Supplier of Electrical and Electronic Components

*Click to view similar products for [Heat Sinks](#) category:*

*Click to view products by [Vicor](#) manufacturer:*

Other Similar products are found below :

[581102B00000G](#) [656-15ABPE](#) [657-20ABPNE](#) [7020B-TC12-MTG](#) [73452PPBA](#) [7G0011A](#) [PF720G](#) [A22-4026](#) [120-1873-007](#) [HAH10L](#)  
[HAH15L](#) [1542616-1](#) [HS-2506-F1](#) [HS-87M0-F2](#) [218-40CTE3](#) [231-69PAB-15V](#) [25-7520](#) [SW50-4G](#) [231-75PAB-13V](#) [231-75PAB-15V](#) [253-](#)  
[122ABE-22](#) [PSC22CB](#) [HAF10L](#) [HAQ10T](#) [D10100-28](#) [BDN183CBA01](#) [3-21053-4](#) [32438](#) [TX0506-1B](#) [TX1806B](#) [LAE66A3CB](#) [WA-DT2-](#)  
[101E](#) [511-3U](#) [73381PPBA](#) [73403PPBA](#) [7G0047C](#) [COMX-440-HSP](#) [510-12M](#) [D10650-40T5](#) [V8511 Y](#) [APF40-40-13CB/A01](#)  
[780653U04500G](#) [ATS-54310K-C2-R0](#) [FK 216 CB SA](#) [FK 231 SA 220](#) [648-51AB](#) [657-20ABPESC](#) [2341BG](#) [679-25AG](#) [FK 212 CB SA](#)