



Non-Isolated, Fixed-Ratio, Bidirectional DC-DC Converter

Features & Benefits

- 97.9% peak efficiency
- Bidirectional start up and steady-state operation
- Up to 4.5kW/in³ power density
- Maximum continuous output power: 800W
 - Up to 1kW, 2ms peak power capability
- Rated output current (step-down operation):
 - 60A continuous
 - 100A transient, up to 2ms
- Rated output current (step-up operation):
 - 15A continuous
 - 25A transient, up to 2ms
- Parallel operation for multi-kW arrays
- OV, OC, UV, short circuit and thermal shut down
- Simple implementation, no external components required
- Built-in hot-swap capabilities and inrush current limiting

Typical Applications

- DC Power Distribution
- High-Performance Computing Systems (HPC)
- Mild Hybrid and Autonomous Vehicles
- Automated Test Equipment (ATE)
- Industrial Systems
- High-Density Power Supplies
- Communications Systems
- Transportation
- Bidirectional DC Energy Storage

Product Ratings (Step-Down Operation)

$V_{HI} = 54V$ (40 – 60V)	$I_{LO} =$ up to 60A
$V_{LO} = 13.5V$ (10 – 15V) (NO LOAD)	$K = 1/4$

Product Description

The NBM2317S60E1560T0R is a high-efficiency Non-Isolated Bus Converter operating from a 40 to 60V_{DC} high-side voltage bus to deliver a ratiometric low-side voltage from 10 to 15V_{DC}.

The NBM2317S60E1560T0R offers low noise, fast transient response, and industry-leading efficiency and power density. In addition, it provides an AC impedance beyond the bandwidth of most downstream regulators, allowing input capacitance normally located at the input of a PoL regulator to be located at the high side of the NBM. With a high-side to low-side K factor of 1/4, that capacitance value can be reduced by a factor of 16x, resulting in savings of board area, material and total system cost.

Leveraging the thermal and density benefits of Vicor SM-ChiP packaging technology, the NBM offers flexible thermal management options with very low top- and bottom-side thermal impedances. Thermally-adept SM-ChiP-based power components enable customers to achieve low-cost power system solutions with previously unattainable system size, weight and efficiency attributes quickly and predictably.

The NBM non-isolated topology allows bidirectional start up and steady-state operation and provides bidirectional fault detection and shut down.

Package Information

- Thermally-Adept SM-ChiP™
- 22.83 x 17.34 x 7.42mm
[0.899 x 0.683 x 0.292in]
- Weight: 12g

Note: Product images may not highlight current product markings.

Typical Applications

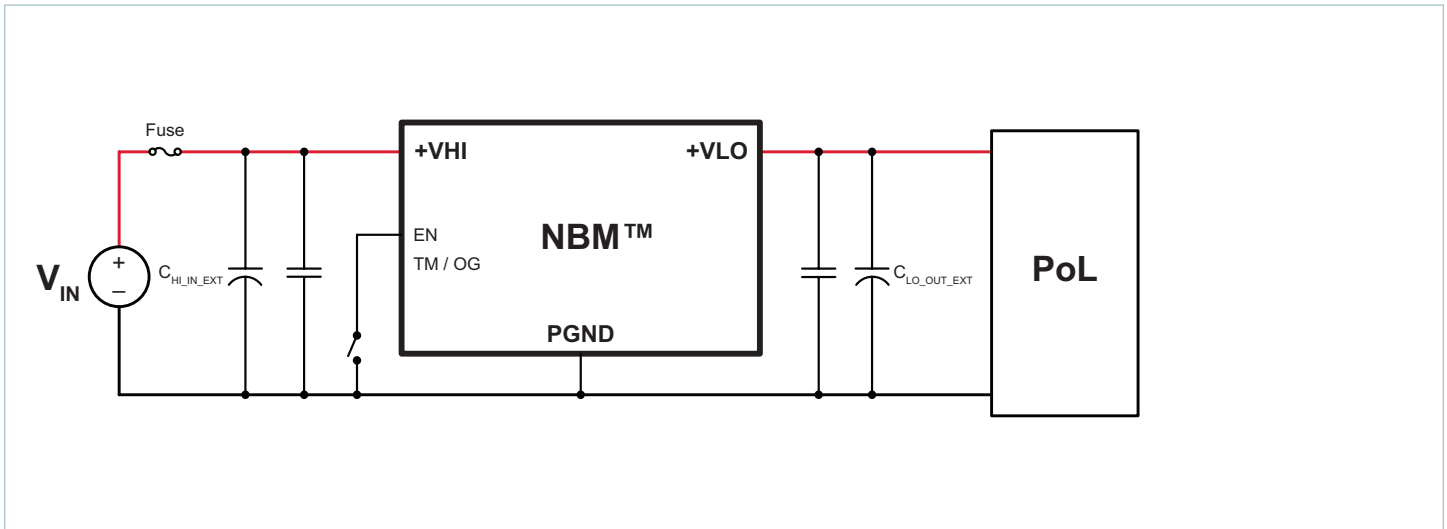

NBM2317S60E1560T0R + point-of-load

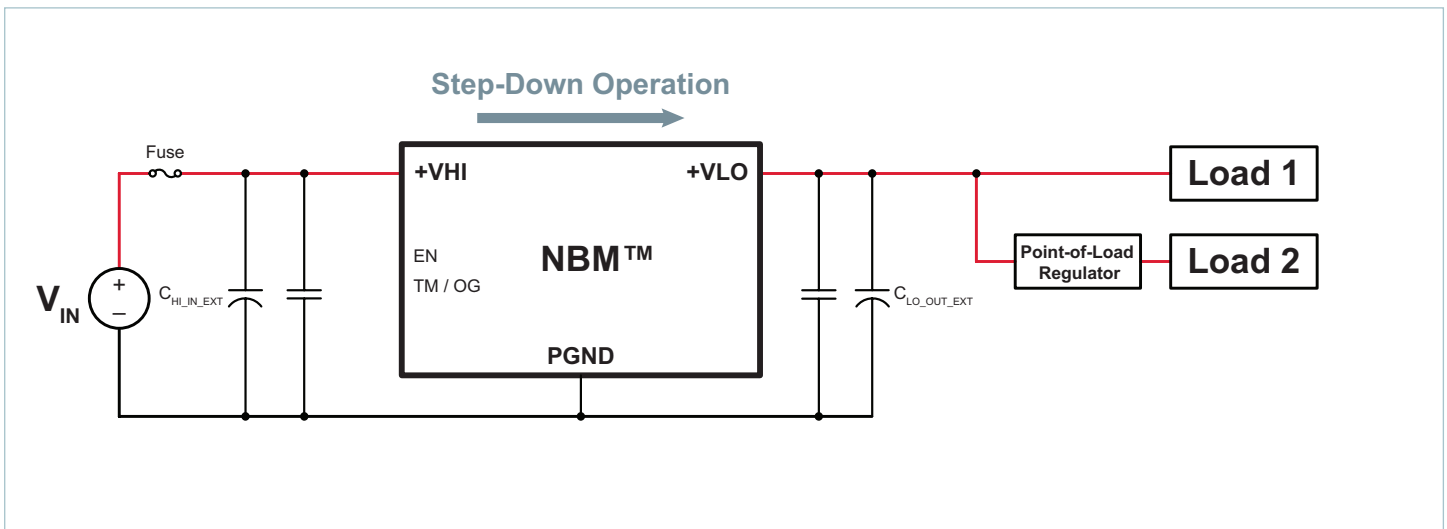

NBM2317S60E1560T0R in step-down operation powering point-of-load regulator and direct load

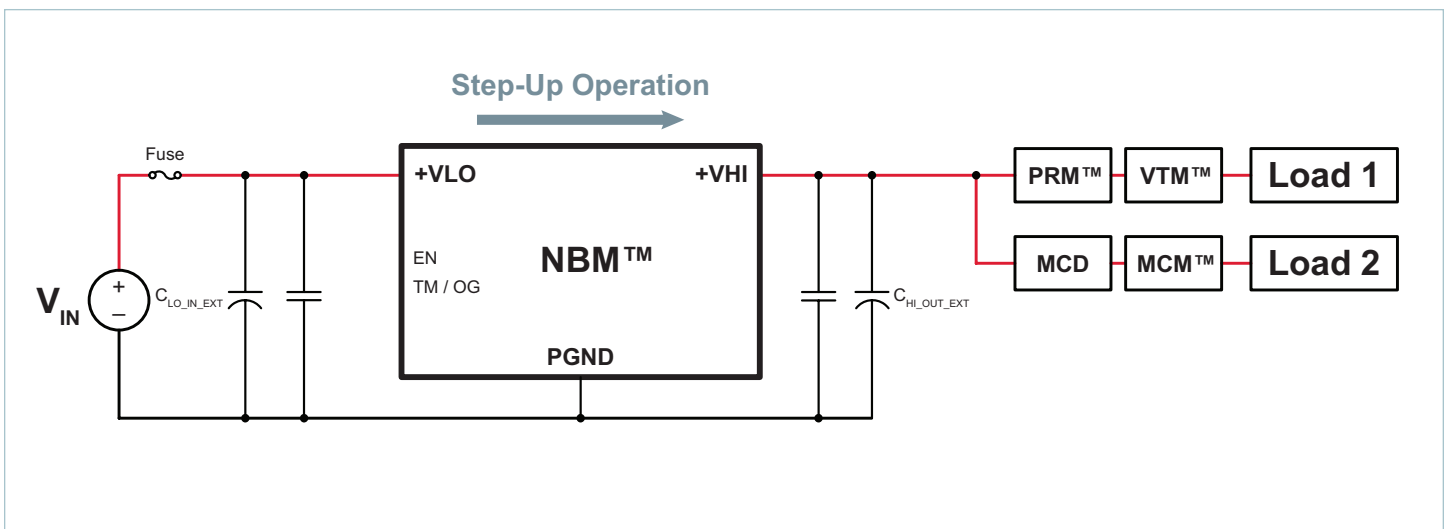

NBM2317S60E1560T0R in step-up operation powering PRM + VTM and MCD + MCM

Terminal Configuration

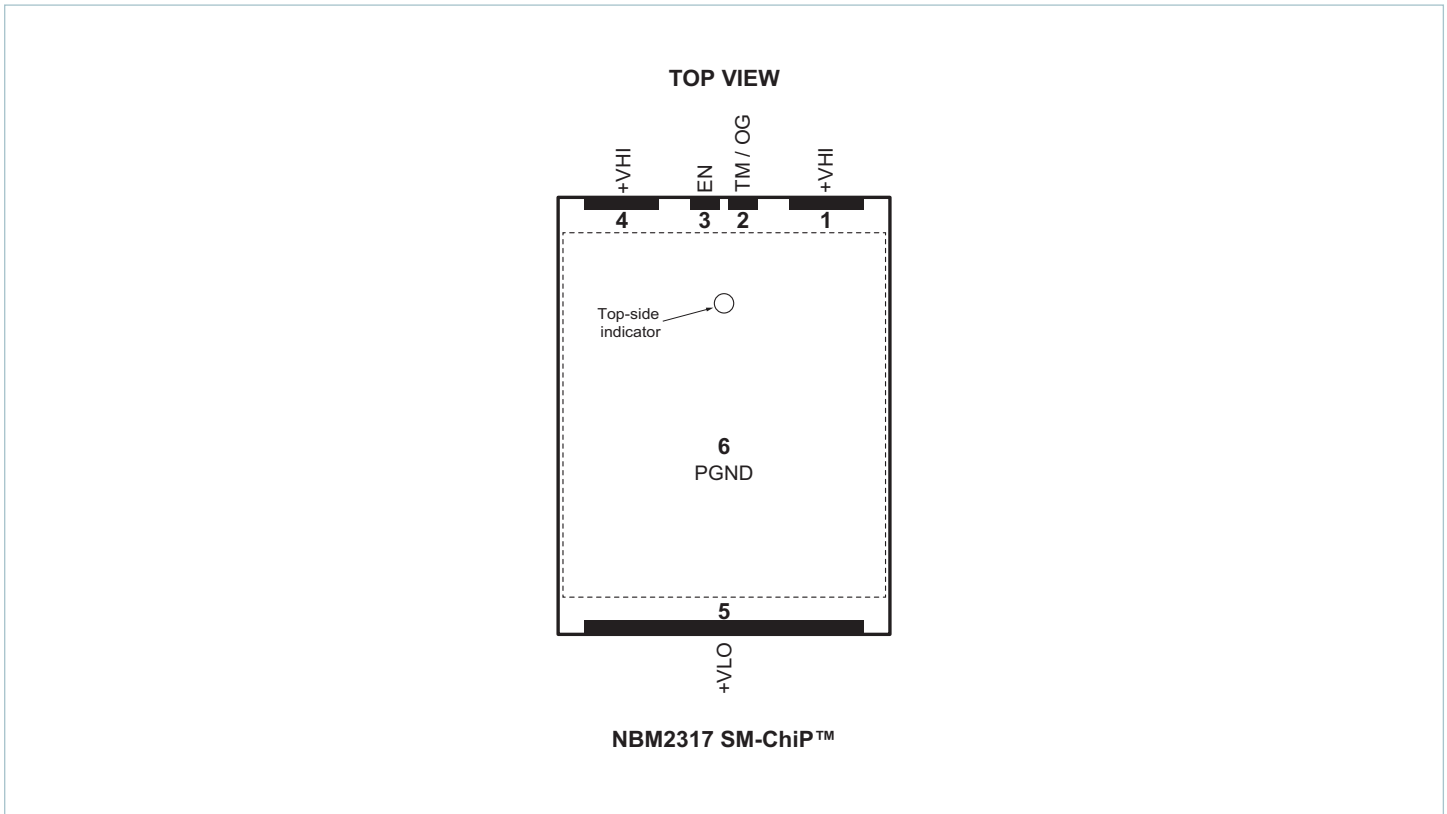

Terminal Descriptions

Terminal Number	Signal Name	Type	Function
1, 4	+VHI	HIGH SIDE POWER	High-side power positive terminals
2	TM / OG	OUTPUT	Temperature Monitor and Output Good
3	EN	INPUT	Enables / disables NBM. When held low, the unit will be disabled
5	+VLO	LOW SIDE POWER	Low-side power positive terminal
6	PGND	POWER RETURN	Common negative high-side and low-side power return terminal

Part Ordering Information

Part Number	Temperature Grade	Option	Tray Size
NBM2317S60E1560TOR	T = -40 to 125°C	OR = Reversible Analog Control	55 parts per tray

All products shipped in JEDEC standard high-profile (0.400in thick) trays (JEDEC Publication 95, Design Guide 4.10).

Storage and Handling Information

Note: For compressive loading refer to [Application Note AN:036](#), "Recommendations for Maximum Compressive Force of Heat Sinks."

Attribute	Comments	Specification
Storage Temperature Range	T-Grade	-40 to 125°C
Operating Internal Temperature Range (T _{INT})	T-Grade	-40 to 125°C
Weight		12g
Package Plating		100 – 300µin nickel, 2 –5µin gold
MSL Rating		MSL4, 245°C maximum reflow temperature
ESD Rating	Human Body Model ESDA / JEDEC JDS-001-2012	Class 1C, 1kV to < 2kV
	Charged Device Model JESD22-C101-E	CLASS II, 200V to < 500V

Reliability and Agency Approvals

Attribute	Comments	Value	Unit
MTBF	Telcordia Issue 2, Method I Case 3; 25°C Ground Benign, Controlled	15.0	MHrs
	MIL-HDBK-217Plus Parts Count - 25°C Ground Benign, Stationary, Indoors / Computer	6.46	
Agency Approvals/Standards	cTÜVus EN 60950-1		
	CE Marked for Low Voltage Directive and RoHS Recast Directive, as applicable		

Absolute Maximum Ratings

The absolute maximum ratings below are stress ratings only. Operation at or beyond these maximum ratings can cause permanent damage to the device.

Parameter	Comments	Min	Max	Unit
+VHI to PGND		-1	80	V
VHI or VLO Slew Rate	Operational		1	V/µs
+VLO to PGND		-1	17.5	V
TM / OG to PGND		-0.3	7	V
EN to PGND			15	V

Electrical Specifications

Specifications apply over all line and load conditions, unless otherwise noted; **boldface** specifications apply over the temperature range of $-40^{\circ}\text{C} \leq T_{\text{INTERNAL}} \leq 125^{\circ}\text{C}$ (T-Grade); all other specifications are at $T_{\text{INTERNAL}} = 25^{\circ}\text{C}$ unless otherwise noted.

Attribute	Symbol	Conditions / Notes	Min	Typ	Max	Unit
General Powertrain Specification – Step-Down Operation (High-Voltage Side to Low-Voltage Side)						
High-Side Input Voltage Range (Continuous)	$V_{\text{HI_DC}}$		40		60	V
High-Side Input Quiescent Current	$I_{\text{HI_Q}}$	Disabled, EN low, $V_{\text{HI_DC}} = 54\text{V}$		1.5		mA
		$T_{\text{INTERNAL}} \leq 100^{\circ}\text{C}$			3.0	
No Load Power Dissipation	$P_{\text{HI_NL}}$	$V_{\text{HI_DC}} = 54\text{V}$, $T_{\text{INTERNAL}} = 25^{\circ}\text{C}$		3.6	7	W
		$V_{\text{HI_DC}} = 54\text{V}$	2		11	
		$V_{\text{HI_DC}} = 40 - 60\text{V}$, $T_{\text{INTERNAL}} = 25^{\circ}\text{C}$			8	
		$V_{\text{HI_DC}} = 40 - 60\text{V}$			14.5	
High-Side Input Inrush Current Peak	$I_{\text{HI_INR_PK}}$	$V_{\text{HI_DC}} = 54\text{V}$, $C_{\text{LO_EXT}} = 1000\mu\text{F}$, no load		7.5		A
		$T_{\text{INTERNAL}} \leq 100^{\circ}\text{C}$			12	
DC High-Side Input Current	$I_{\text{HI_IN_DC}}$	At $I_{\text{LO_OUT_DC}} = 60\text{A}$, $T_{\text{INTERNAL}} \leq 100^{\circ}\text{C}$			16.3	A
Transformation Ratio	K	High voltage side to low voltage side, $K = V_{\text{LO_DC}} / V_{\text{HI_DC}}$, at no load		1/4		V/V
Low-Side Output Current	$I_{\text{LO_OUT_DC}}$	Continuous; $40\text{V} \leq V_{\text{HI_DC}} \leq 60\text{V}$			60	A
	$I_{\text{LO_OUT_PULSE}}$	2ms pulse, 25% duty cycle, $I_{\text{LO_OUT_AVG}} \leq 50\%$ rated $I_{\text{LO_OUT_DC}}$			100	A
Low-Side Output Power	$P_{\text{LO_OUT_DC}}$	Continuous; $54\text{V} < V_{\text{HI_DC}} \leq 60\text{V}$			800	W
	$P_{\text{LO_OUT_PULSE}}$	2ms pulse, 25% duty cycle, $P_{\text{LO_OUT_AVG}} \leq 50\%$ rated $P_{\text{LO_OUT_DC}}$			1000	W
Efficiency (Ambient)	η_{AMB}	$V_{\text{HI_DC}} = 54\text{V}$, $I_{\text{LO_OUT_DC}} = 60\text{A}$	97.0	97.4		%
		$V_{\text{HI_DC}} = 40 - 60\text{V}$, $I_{\text{LO_OUT_DC}} = 60\text{A}$	96.2			
		$V_{\text{HI_DC}} = 54\text{V}$, $I_{\text{LO_OUT_DC}} = 30\text{A}$	97.3	97.8		
Efficiency (Hot)	η_{HOT}	$V_{\text{HI_DC}} = 54\text{V}$, $I_{\text{LO_OUT_DC}} = 60\text{A}$	96.7	97.4		%
		$V_{\text{HI_DC}} = 54\text{V}$, $I_{\text{LO_OUT_DC}} = 30\text{A}$	97.3	97.9		
Efficiency (Over Load Range)	$\eta_{20\%}$	$12\text{A} < I_{\text{LO_OUT_DC}} < 60\text{A}$	92.0			%
Low-Side Output Resistance	$R_{\text{LO_COLD}}$	$V_{\text{HI_DC}} = 54\text{V}$, $I_{\text{LO_OUT_DC}} = 60\text{A}$, $T_{\text{INTERNAL}} = -40^{\circ}\text{C}$	2.6	3.3	4	m Ω
	$R_{\text{LO_AMB}}$	$V_{\text{HI_DC}} = 54\text{V}$, $I_{\text{LO_OUT_DC}} = 60\text{A}$	3.5	4.4	5.3	
	$R_{\text{LO_HOT}}$	$V_{\text{HI_DC}} = 54\text{V}$, $I_{\text{LO_OUT_DC}} = 60\text{A}$, $T_{\text{INTERNAL}} = 100^{\circ}\text{C}$	4.4	5.5	5.7	
Switching Frequency	F_{SW}	Low-side voltage ripple frequency = $2x F_{\text{SW}}$		1.62		MHz
Low-Side Output Voltage Ripple	$V_{\text{LO_OUT_PP}}$	$C_{\text{LO_OUT_EXT}} = 0\mu\text{F}$, $I_{\text{LO_OUT_DC}} = 60\text{A}$, $V_{\text{HI_DC}} = 54\text{V}$, 20MHz BW		120		mV
		$T_{\text{INTERNAL}} \leq 100^{\circ}\text{C}$			180	
Effective High-Side Input Capacitance (Internal)	$C_{\text{HI_INT}}$	Effective value at $54V_{\text{HI_DC}}$		11.2		μF
Effective Low-Side Output Capacitance (Internal)	$C_{\text{LO_INT}}$	Effective value at $13.5V_{\text{LO_DC}}$		55		μF
Rated Low-Side Output Capacitance	$C_{\text{LO_OUT_EXT}}$	Excessive capacitance may drive module into short circuit fault			1000	μF
	$C_{\text{LO_OUT_AEXT}}$	Parallel array operation; $C_{\text{LO_OUT_AEXT}} \text{ Max} = N \cdot 0.5 \cdot C_{\text{LO_OUT_EXT}} \text{ MAX}$, where N = the number of units in parallel				μF

Electrical Specifications (Cont.)

Specifications apply over all line and load conditions, unless otherwise noted; **boldface** specifications apply over the temperature range of $-40^{\circ}\text{C} \leq T_{\text{INTERNAL}} \leq 125^{\circ}\text{C}$ (T-Grade); all other specifications are at $T_{\text{INTERNAL}} = 25^{\circ}\text{C}$ unless otherwise noted.

Attribute	Symbol	Conditions / Notes	Min	Typ	Max	Unit
Powertrain Fault Shut-Down Specification – Step-Down Operation (High-Voltage Side to Low-Voltage Side), Cont.						
Auto Restart Time	$t_{\text{AUTO_RESTART}}$	Start up into a persistent fault condition. Non-latching fault detection given $V_{\text{HI_DC}} > V_{\text{HI_UVLO+}}$	350	500	600	ms
High-Side Input Overvoltage Lockout Threshold	$V_{\text{HI_OVLO+}}$			64.6	66	V
High-Side Input Overvoltage Recovery Threshold	$V_{\text{HI_OVLO-}}$		60	64		V
High-Side Input Overvoltage Lockout Hysteresis	$V_{\text{HI_OVLO_HYST}}$			0.4		V
High-Side Input Overvoltage Lockout Response Time	$t_{\text{HI_OVLO}}$			1		μs
High-Side Input Undervoltage Lockout Threshold	$V_{\text{HI_UVLO-}}$		31.6	33.2		V
High-Side Input Undervoltage Recovery Threshold	$V_{\text{HI_UVLO+}}$			35	40	V
High-Side Input Undervoltage Lockout Hysteresis	$V_{\text{HI_UVLO_HYST}}$			2		V
High-Side Input Undervoltage Lockout Response Time	$t_{\text{HI_UVLO}}$			100		μs
Input-to-Output Undervoltage Start-Up Delay	$t_{\text{HI_TO_LO_DELAY}}$	From $V_{\text{HI_DC}} = V_{\text{HI_UVLO+}}$ to powertrain active, EN floating (i.e., one-time start-up delay from application of $V_{\text{HI_DC}}$ to $V_{\text{LO_DC}}$)			600	ms
Low-Side Output Soft-Start Ramp Time	$t_{\text{LO_SOFT_START}}$	From powertrain active; fast current limit fault detection disabled during soft start		0.5		ms
Low-Side Output Overcurrent Trip Threshold	$I_{\text{LO_OUT_OCP}}$		61	75	110	A
Low-Side Output Overcurrent Response Time Constant	$t_{\text{LO_OUT_OCP}}$	Effective internal RC filter	2	5		ms
Low-Side Output Short Circuit Fault Trip Threshold	$I_{\text{LO_OUT_SCP}}$		100			A
Low-Side Output Short Circuit Fault Response Time	$t_{\text{LO_OUT_SCP}}$			1		μs
Overtemperature Shutdown Threshold	$t_{\text{OTP+}}$	Temperature sensor located inside controller IC	125			$^{\circ}\text{C}$
Overtemperature Recovery Threshold	$t_{\text{OTP-}}$		105	110	115	$^{\circ}\text{C}$
Undertemperature Shutdown Threshold	t_{UTP}	Temperature sensor located inside controller IC			-45	$^{\circ}\text{C}$

Electrical Specifications (Cont.)

Specifications apply over all line and load conditions, unless otherwise noted; **boldface** specifications apply over the temperature range of $-40^{\circ}\text{C} \leq T_{\text{INTERNAL}} \leq 125^{\circ}\text{C}$ (T-Grade); all other specifications are at $T_{\text{INTERNAL}} = 25^{\circ}\text{C}$ unless otherwise noted.

Attribute	Symbol	Conditions / Notes	Min	Typ	Max	Unit
General Powertrain Specification – Step-Up Operation (Low-Voltage Side to High-Voltage Side)						
Low-Side Input Voltage Range (Start Up)	$V_{\text{LO_DC}}$		10.8		15	V
Low-Side Input Voltage Range (Continuous)			10		15	
Low-Side Input Quiescent Current	$I_{\text{LO_Q}}$	Disabled, EN low, $V_{\text{LO_DC}} = 13.5\text{V}$		0.6		mA
		$T_{\text{INTERNAL}} \leq 100^{\circ}\text{C}$			1.2	
No Load Power Dissipation	$P_{\text{LO_NL}}$	$V_{\text{LO_DC}} = 13.5\text{V}$, $T_{\text{INTERNAL}} = 25^{\circ}\text{C}$		4.3	7	W
		$V_{\text{LO_DC}} = 13.5\text{V}$	3		11	
		$V_{\text{LO_DC}} = 10 - 15\text{V}$, $T_{\text{INTERNAL}} = 25^{\circ}\text{C}$			8	
		$V_{\text{LO_DC}} = 10 - 15\text{V}$			14	
Low-Side Input Inrush Current Peak	$I_{\text{LO_INR_PK}}$	$V_{\text{LO_DC}} = 15\text{V}$, $C_{\text{HI_EXT}} = 68\mu\text{F}$, no load		45		A
		$T_{\text{INTERNAL}} \leq 100^{\circ}\text{C}$			60	
DC Low-Side Input Current	$I_{\text{LO_IN_DC}}$	At $I_{\text{HI_OUT_DC}} = 15\text{A}$, $T_{\text{INTERNAL}} \leq 100^{\circ}\text{C}$			62	A
Transformation Ratio	K	Low-voltage side to high-voltage side, $K = V_{\text{HI_DC}} / V_{\text{LO_DC}}$, at no load		4		V/V
High-Side Output Current	$I_{\text{HI_OUT_DC}}$	Continuous; $10\text{V} \leq V_{\text{LO_DC}} \leq 13.5\text{V}$			15	A
	$I_{\text{HI_OUT_PULSE}}$	2ms pulse, 25% duty cycle, $I_{\text{HI_OUT_AVG}} \leq 50\%$ rated $I_{\text{HI_OUT_DC}}$			25	A
High-Side Output Power	$P_{\text{HI_OUT_DC}}$	Continuous; $13.5\text{V} < V_{\text{LO_DC}} \leq 15\text{V}$			800	W
	$P_{\text{HI_OUT_PULSE}}$	2ms pulse, 25% duty cycle, $P_{\text{HI_OUT_AVG}} \leq 50\%$ rated $P_{\text{HI_OUT_DC}}$			1000	W
Efficiency (Ambient)	η_{AMB}	$V_{\text{LO_DC}} = 13.5\text{V}$, $I_{\text{HI_OUT_DC}} = 15\text{A}$	96.9	97.3		%
		$V_{\text{LO_DC}} = 10 - 15\text{V}$, $I_{\text{HI_OUT_DC}} = 15\text{A}$	96.2			
		$V_{\text{LO_DC}} = 13.5\text{V}$, $I_{\text{HI_OUT_DC}} = 7.5\text{A}$	97.3	97.9		
Efficiency (Hot)	η_{HOT}	$V_{\text{LO_DC}} = 13.5\text{V}$, $I_{\text{HI_OUT_DC}} = 15\text{A}$	96.7	97.0		%
		$V_{\text{LO_DC}} = 13.5\text{V}$, $I_{\text{HI_OUT_DC}} = 7.5\text{A}$	97.3	97.8		
Efficiency (Over Load Range)	$\eta_{20\%}$	$3\text{A} < I_{\text{HI_OUT_DC}} < 15\text{A}$	92.0			%
High-Side Output Resistance	$R_{\text{HI_COLD}}$	$V_{\text{LO_DC}} = 13.5\text{V}$, $I_{\text{HI_OUT_DC}} = 15\text{A}$, $T_{\text{INTERNAL}} = -40^{\circ}\text{C}$	50	65	80	m Ω
	$R_{\text{HI_AMB}}$	$V_{\text{LO_DC}} = 13.5\text{V}$, $I_{\text{HI_OUT_DC}} = 15\text{A}$	62	80	98	
	$R_{\text{HI_HOT}}$	$V_{\text{LO_DC}} = 13.5\text{V}$, $I_{\text{HI_OUT_DC}} = 15\text{A}$, $T_{\text{INTERNAL}} = 100^{\circ}\text{C}$	75	97	118	
Switching Frequency	F_{SW}	High-side output voltage ripple frequency = $2x F_{\text{SW}}$		1.62		MHz
High-Side Output Voltage Ripple	$V_{\text{HI_OUT_PP}}$	$C_{\text{HI_OUT_EXT}} = 0\mu\text{F}$, $I_{\text{HI_OUT_DC}} = 15\text{A}$, $V_{\text{LO_DC}} = 13.5\text{V}$, 20MHz BW		138		mV
		$T_{\text{INTERNAL}} \leq 100^{\circ}\text{C}$			200	
Effective Low-Side Input Capacitance (Internal)	$C_{\text{LO_INT}}$	Effective value at $13.5V_{\text{LO_DC}}$		55		μF
Effective High-Side Output Capacitance (Internal)	$C_{\text{HI_INT}}$	Effective value at $54V_{\text{HI_DC}}$		11.2		μF
Rated High-Side Output Capacitance	$C_{\text{HI_OUT_EXT}}$	At start up with no load; excessive capacitance may prevent module start up			68	μF
	$C_{\text{HI_OUT_AEXT}}$	Parallel array operation; $C_{\text{HI_OUT_AEXT Max}} = N \cdot 0.5 \cdot C_{\text{HI_OUT_EXT Max}}$, where N = the number of units in parallel				μF

Electrical Specifications (Cont.)

Specifications apply over all line and load conditions, unless otherwise noted; **boldface** specifications apply over the temperature range of $-40^{\circ}\text{C} \leq T_{\text{INTERNAL}} \leq 125^{\circ}\text{C}$ (T-Grade); all other specifications are at $T_{\text{INTERNAL}} = 25^{\circ}\text{C}$ unless otherwise noted.

Attribute	Symbol	Conditions / Notes	Min	Typ	Max	Unit
Powertrain Fault Shut-Down Specification – Step-Up Operation (Low-Voltage Side to High-Voltage Side), Cont.						
Auto Restart Time	$t_{\text{AUTO_RESTART}}$	Start up into a persistent fault condition. Non-latching fault detection given $V_{\text{LO_DC}} > V_{\text{LO_UVLO+}}$	350	500	600	ms
Low-Side Input Overvoltage Lockout Threshold	$V_{\text{LO_OVLO+}}$			16.7	17.2	V
Low-Side Input Overvoltage Recovery Threshold	$V_{\text{LO_OVLO-}}$		15.4	15.8		V
Low-Side Input Overvoltage Lockout Hysteresis	$V_{\text{LO_OVLO_HYST}}$			0.1		V
Low-Side Input Overvoltage Lockout Response Time	$t_{\text{LO_OVLO}}$			1		μs
Low-Side Input Undervoltage Lockout Threshold	$V_{\text{LO_UVLO-}}$		8.0	8.6		V
Low-Side Input Undervoltage Recovery Threshold	$V_{\text{LO_UVLO+}}$			10.5	10.8	V
Low-Side Input Undervoltage Lockout Hysteresis	$V_{\text{LO_UVLO_HYST}}$			0.1		V
Low-Side Input Undervoltage Lockout Response Time	$t_{\text{LO_UVLO}}$			8		μs
Input-to-Output Start-Up Delay	$t_{\text{LO_TO_HI_DELAY}}$	From $V_{\text{LO_DC}} = V_{\text{LO_UVLO+}}$ to powertrain active, EN floating (i.e., one-time start-up delay from application of $V_{\text{LO_DC}}$ to $V_{\text{HI_DC}}$)			600	ms
High-Side Output Soft-Start Ramp Time	$t_{\text{HI_SOFT_START}}$	From powertrain active.		500		μs
High-Side Output Overcurrent Trip Threshold	$I_{\text{HI_OUT_OCP}}$	Powertrain stops switching; conduction path from low side to high side still exists through body diodes of powertrain MOSFETs ^[a]	15.25	18.75	27.5	A
High-Side Output Overcurrent Response Time Constant	$t_{\text{HI_OUT_OCP}}$	Effective internal RC filter	2	5		ms
Overtemperature Shutdown Threshold	$t_{\text{OTP+}}$	Temperature sensor located inside controller IC	125			$^{\circ}\text{C}$
Overtemperature Recovery Threshold	$t_{\text{OTP-}}$		105	110	115	$^{\circ}\text{C}$
Undertemperature Shutdown Threshold	t_{UTP}	Temperature sensor located inside controller IC			-45	$^{\circ}\text{C}$

^[a] Sustained current through body diodes can cause powertrain damage. See "start up and bidirectional operation" on page 19.

Electrical Specifications (Cont.)

Specifications apply over all line and load conditions, unless otherwise noted; **boldface** specifications apply over the temperature range of $-40^{\circ}\text{C} \leq T_{\text{INTERNAL}} \leq 125^{\circ}\text{C}$ (T-Grade); all other specifications are at $T_{\text{INTERNAL}} = 25^{\circ}\text{C}$ unless otherwise noted.

Attribute	Symbol	Conditions / Notes	Min	Typ	Max	Unit
Temperature Monitor / Output Good (TM / OG) ^[b]						
Powertrain Active to TM / OG Time	$t_{\text{TM/OG}}$	Powertrain active to TM / OG high		1800		μs
TM / OG Voltage Range	$V_{\text{TM/OG}}$		2.12		4.04	V
TM / OG Voltage Reference	$V_{\text{TM/OG_AMB}}$	T_J controller = 27°C	2.95	3	3.05	V
TM / OG Source Current	$I_{\text{TM/OG}}$	TM accuracy = $\pm 5^{\circ}\text{C}$			10	μA
TM / OG Short Circuit Current	$I_{\text{SC_TM/OG}}$	Maximum source current when pulled to ground externally			5	mA
TM / OG Gain	$A_{\text{TM/OG}}$			10		mV / $^{\circ}\text{C}$
TM / OG Voltage Ripple	$V_{\text{TM/OG_PP}}$	$C_{\text{TM/OG}} = 0\text{pF}$, $V_{\text{HI_DC}} = 54\text{V}$, $I_{\text{LO_OUT_DC}} = 60\text{A}$		120	200	mV
TM / OG Capacitance (External)	$C_{\text{TM/OG_EXT}}$				50	pF
TM / OG Fault Response Time	$T_{\text{FR_TM/OG}}$	From fault to TM / OG low		10		μs
TM / OG Voltage	$V_{\text{TM/OG_DIS}}$	TM/OG held low by internal FET		0		V
TM / OG Sinking Current	$I_{\text{SINK_TM/OG}}$	Maximum current TM/OG can sink when pulled low by internal FET			180	mA
Enable / Disable Control (EN) ^[b]						
EN Voltage	V_{EN}		4.7	5	5.3	V
EN Available Current	$I_{\text{EN_OP}}$		2	3.5	5.0	mA
EN Source (Current)	$I_{\text{EN_EN}}$		50	100		μA
EN Resistance (Internal)	$R_{\text{EN_INT}}$	Internal pull-down resistor	50	150	400	k Ω
EN Capacitance (Internal)	$C_{\text{EN_INT}}$				1000	pF
EN Load Resistance	$R_{\text{EN_S}}$	To permit regular operation	60			k Ω
EN Enable Threshold	$V_{\text{EN_EN_TH}}$		2.0	2.5	3.0	V
EN Disable Threshold	$V_{\text{EN_DIS_TH}}$				1.95	V
EN Disable Duration	$t_{\text{EN_DIS_t}}$	Minimum time before attempting re-enable	1			s
EN Threshold Hysteresis	$V_{\text{EN_HYSTER}}$			50		mV
EN Enable to Powertrain Active Time	$t_{\text{EN_START}}$	$V_{\text{HI_DC}} > V_{\text{HI_UVLO+}}$, EN held low. Both conditions satisfied for time $> t_{\text{HI_TO_LO_DELAY}}$	5	10	30	μs
EN Disable to VOUT Time	$t_{\text{EN_DIS}}$			4	10	μs
EN Fault Response Time	$t_{\text{FR_EN}}$	From fault to EN low		100		μs

^[b] See signal terminal description section on page 19.

Operating Area

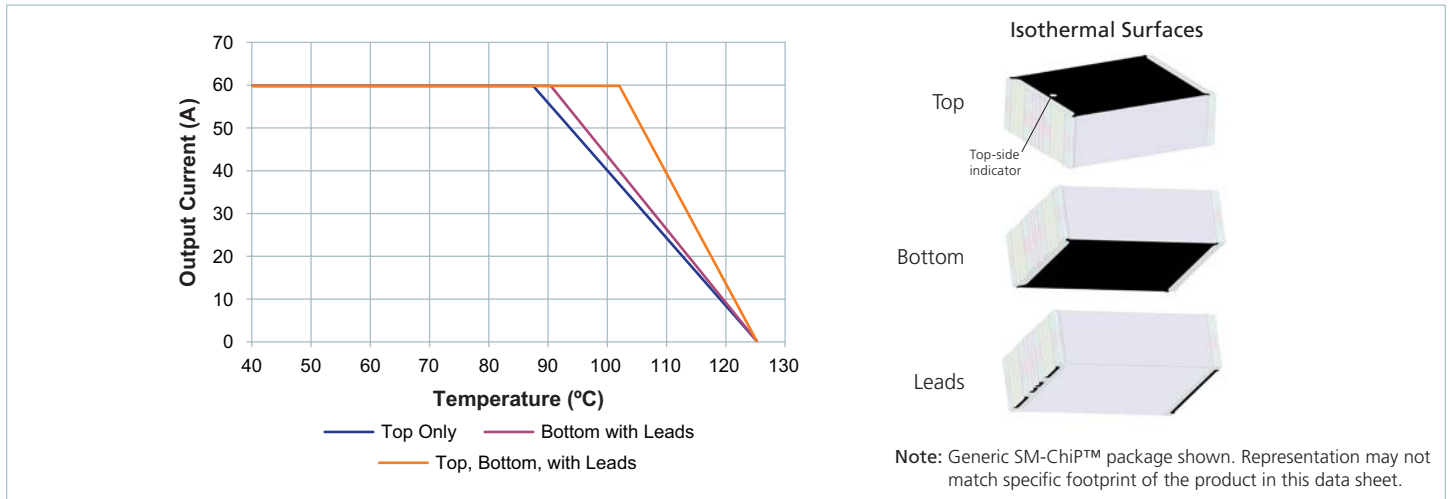

Figure 1 — Specified thermal operating area

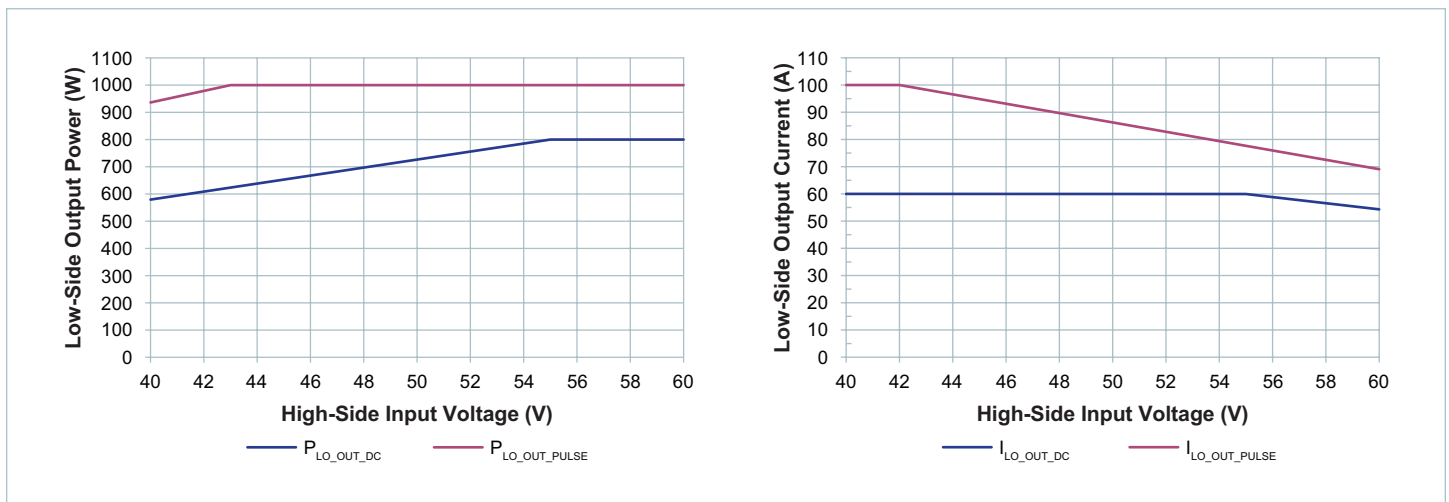

Figure 2 — Specified electrical operating area, step-down operation

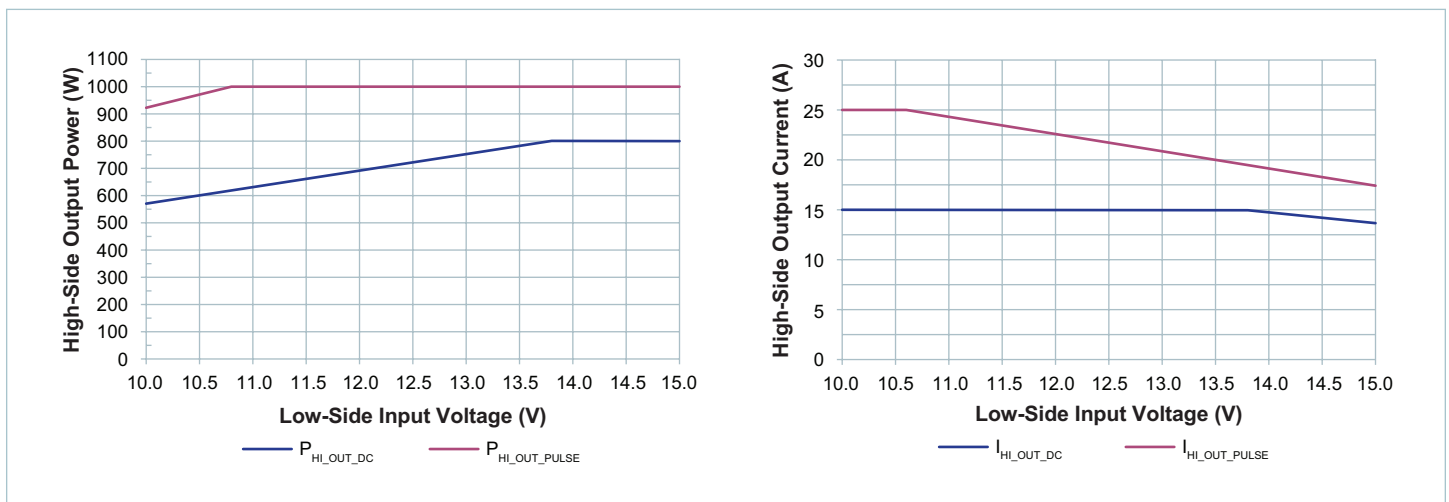

Figure 3 — Specified electrical operating area, step-up operation

Application Characteristics, Step-Down Operation

Temperature controlled via top side cold plate, unless otherwise noted. All data presented in this section are collected from units operating in step-down mode, processing power from high-voltage side to low-voltage side. See associated figures for general trend data.

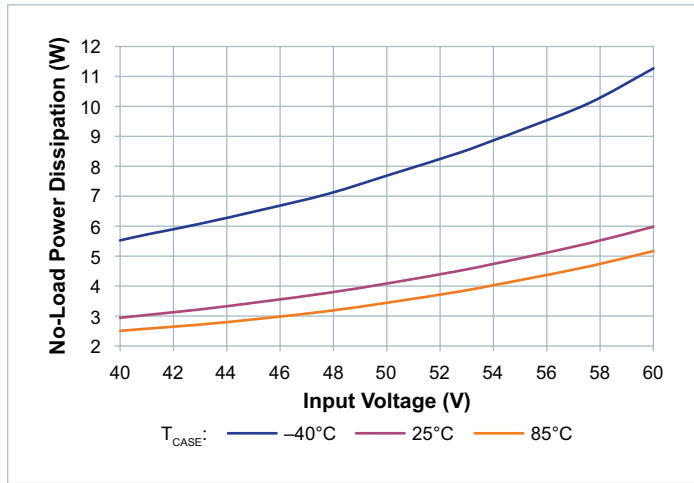

Figure 4 — No-load power dissipation vs. V_{HI_DC}

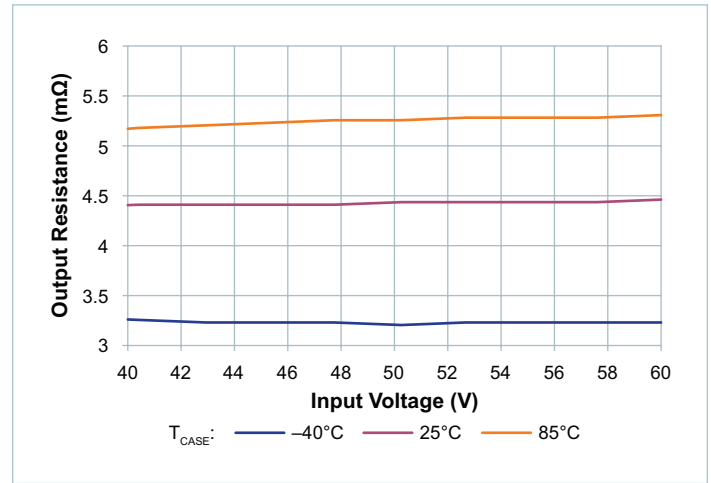

Figure 5 — R_{LO} vs. R_{HI_IN} , $I_{LO_DC} = 60A$

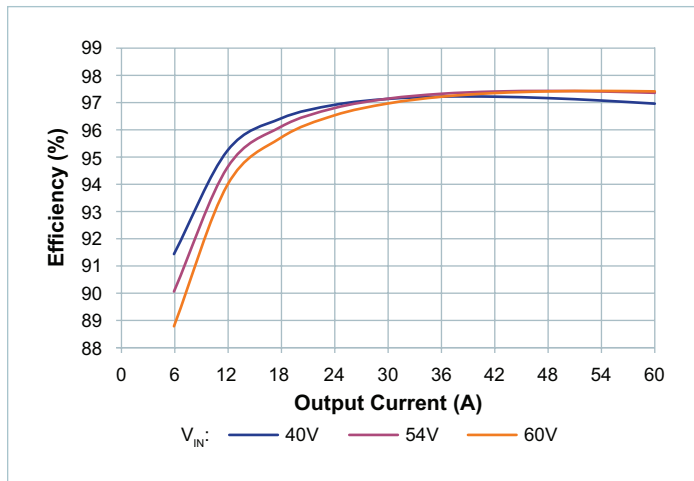

Figure 6 — Efficiency at $T_{CASE} = -40^{\circ}C$

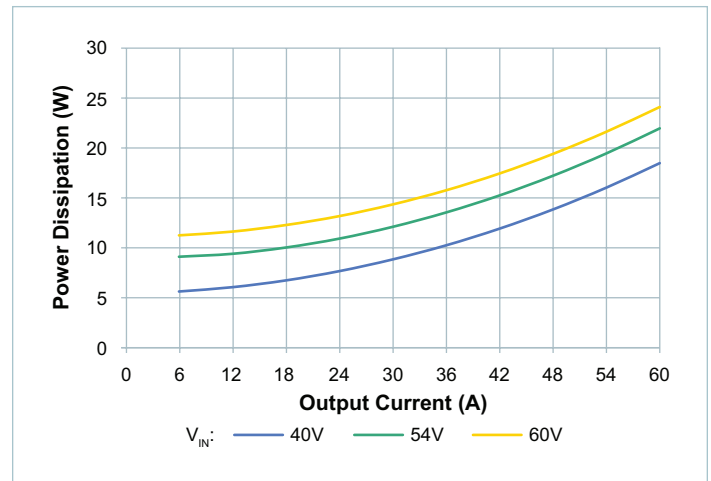

Figure 7 — Power dissipation at $T_{CASE} = -40^{\circ}C$

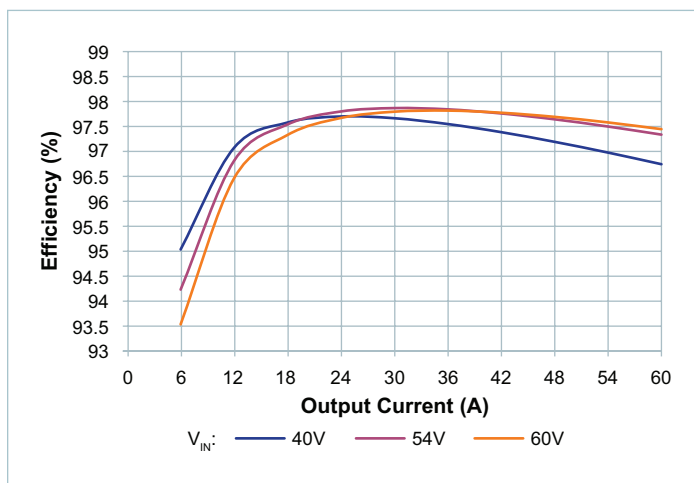

Figure 8 — Efficiency at $T_{CASE} = 25^{\circ}C$

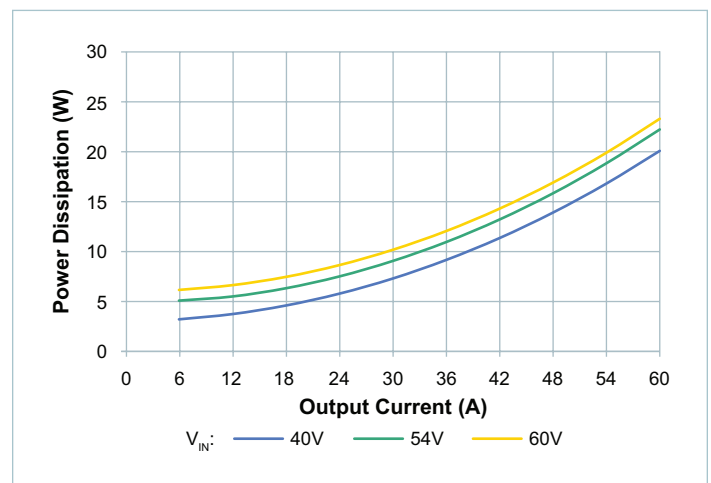

Figure 9 — Power dissipation at $T_{CASE} = 25^{\circ}C$

Application Characteristics, Step-Down Operation (Cont.)

Temperature controlled via top side cold plate, unless otherwise noted. All data presented in this section are collected from units operating in step-down mode, processing power from high-voltage side to low-voltage side. See associated figures for general trend data.

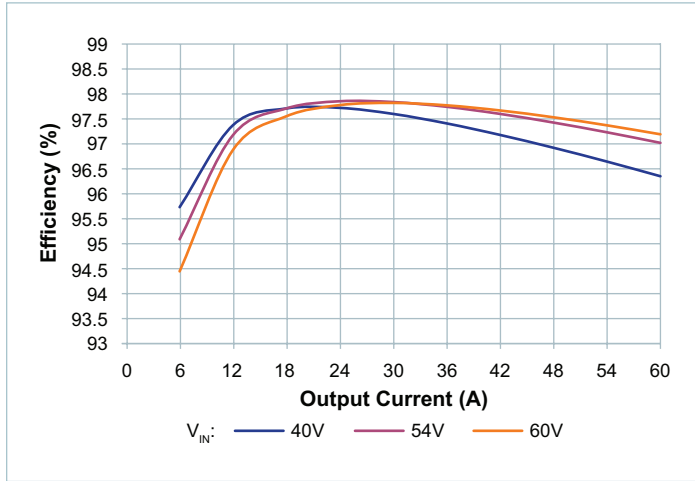

Figure 10 — Efficiency at $T_{CASE} = 85^{\circ}C$

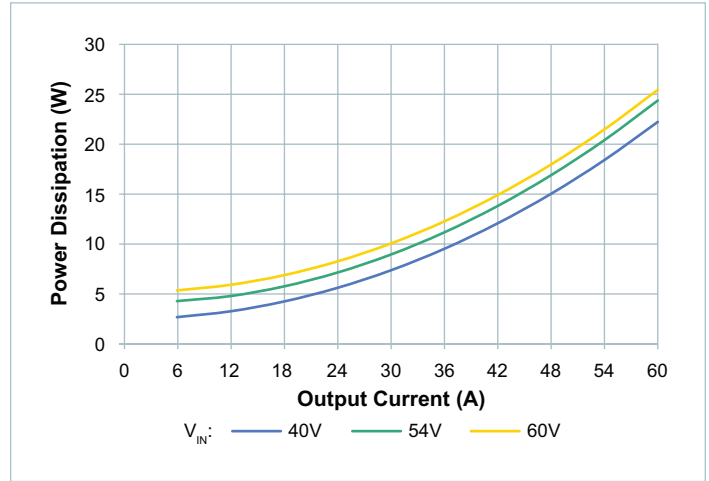

Figure 11 — Power dissipation at $T_{CASE} = 85^{\circ}C$

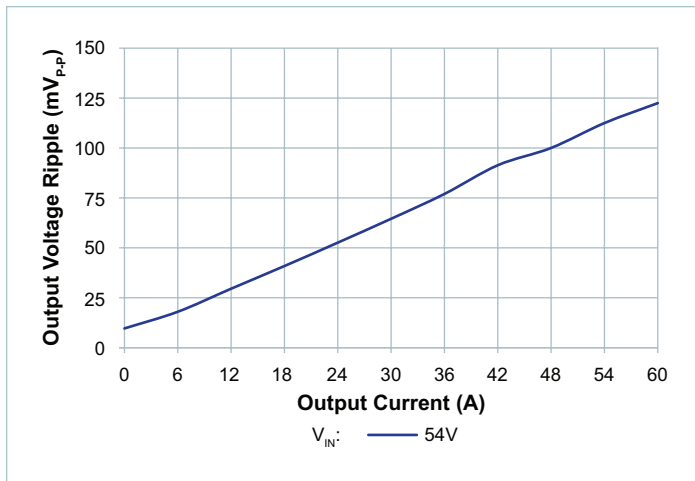

Figure 12 — $V_{LO_OUT_PP}$ vs. I_{LO_DC} ; no external $C_{LO_OUT_EXT}$. Board-mounted module, scope setting: 20MHz analog BW

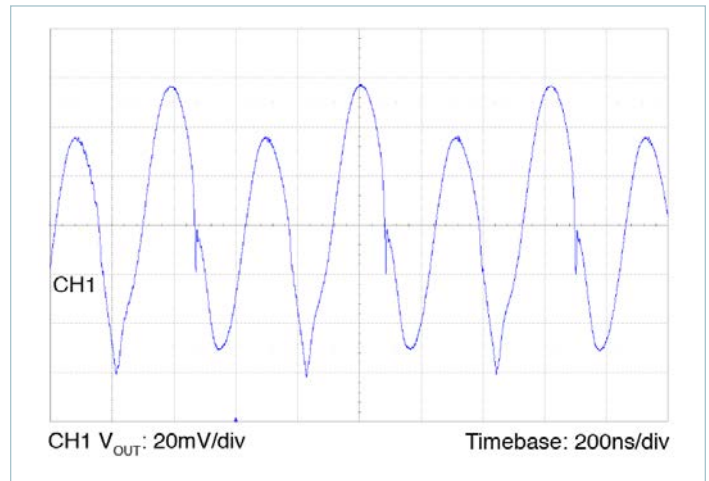

Figure 13 — Full-load low-side voltage ripple, $68\mu F C_{HI_IN_EXT}$; no external $C_{LO_OUT_EXT}$. Board-mounted module, scope setting: 20MHz analog BW

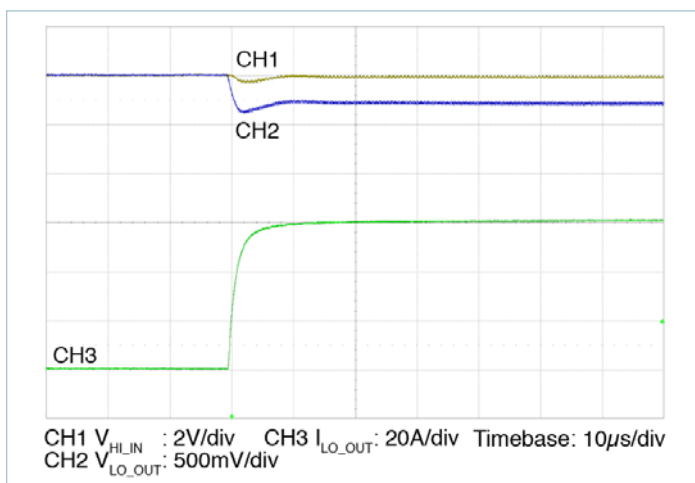

Figure 14 — 0 – 60A transient response: $C_{HI_IN_EXT} = 68\mu F$, no external $C_{LO_OUT_EXT}$

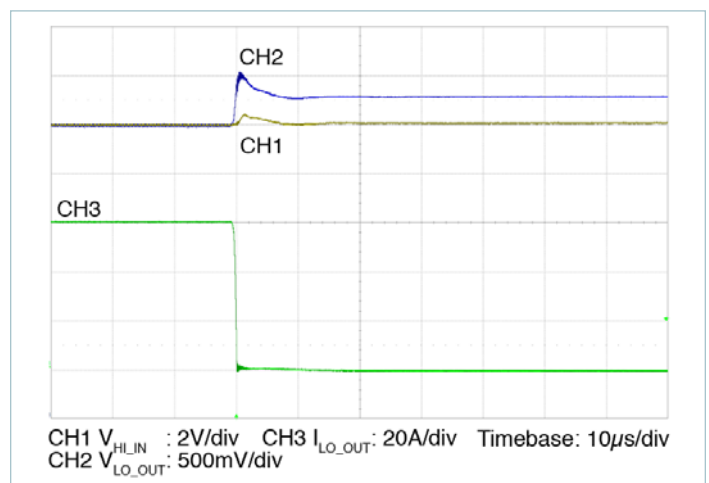

Figure 15 — 60 – 0A transient response: $C_{HI_IN_EXT} = 68\mu F$, no external $C_{LO_OUT_EXT}$

Application Characteristics, Step-Down Operation (Cont.)

Temperature controlled via top side cold plate, unless otherwise noted. All data presented in this section are collected from units operating in step-down mode, processing power from high-voltage side to low-voltage side. See associated figures for general trend data.

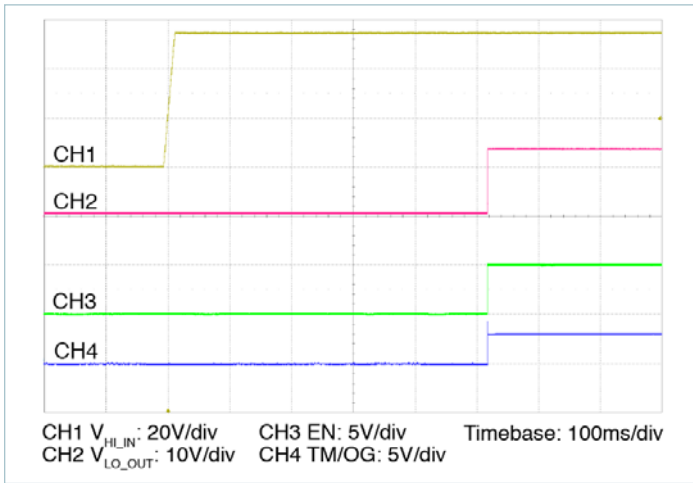

Figure 16 — Start up from application of $V_{HI_DC} = 54V$, $C_{LO_OUT_EXT} = 1000\mu F$, no load

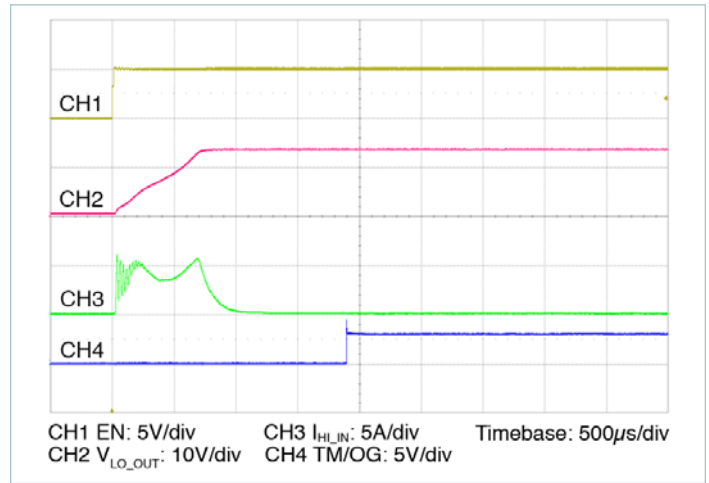

Figure 17 — Start up from application of EN with pre-applied $V_{HI_DC} = 54V$, $C_{LO_OUT_EXT} = 1000\mu F$, no load

Application Characteristics, Step-Up Operation

Temperature controlled via top-side cold plate, unless otherwise noted. All data presented in this section are collected from units operating in step-up mode, processing power from low-voltage side to high-voltage side. See associated figures for general trend data.

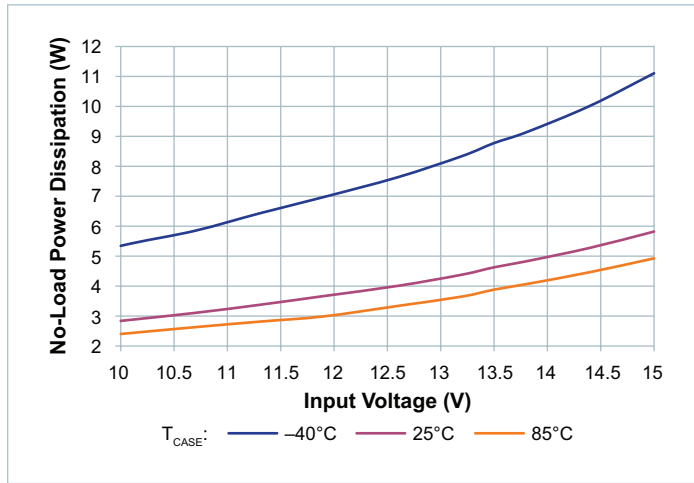

Figure 18 — No-load power dissipation vs. V_{LO_DC}

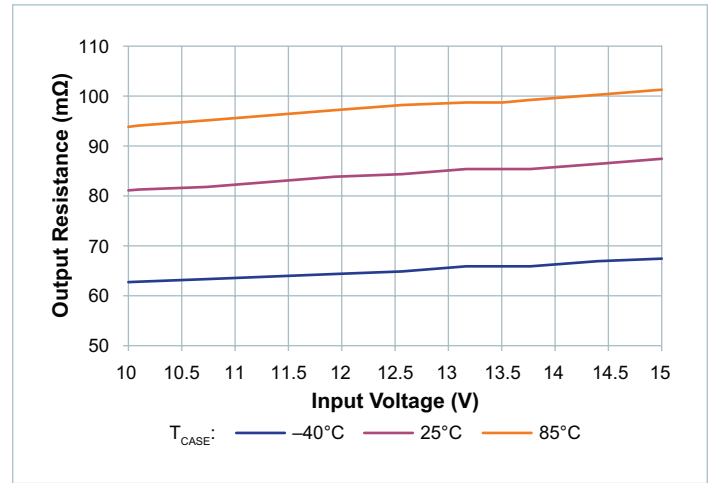

Figure 19 — R_{HI} vs. R_{LO_IN} , $I_{HI_DC} = 15A$

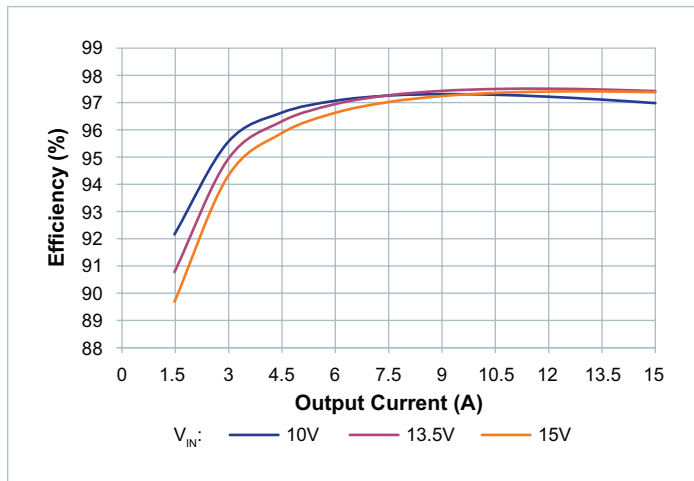

Figure 20 — Efficiency at $T_{CASE} = -40^{\circ}C$

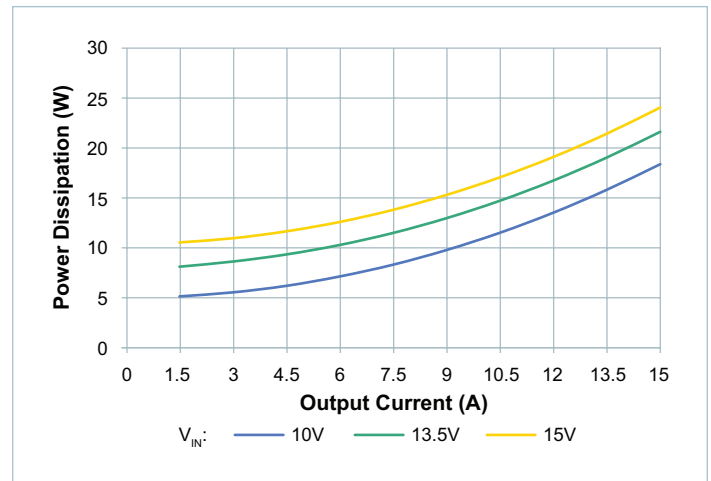

Figure 21 — Power dissipation at $T_{CASE} = -40^{\circ}C$

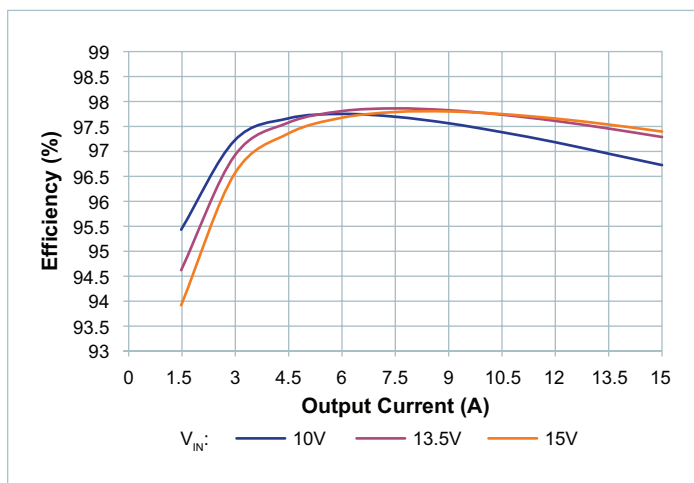

Figure 22 — Efficiency at $T_{CASE} = 25^{\circ}C$

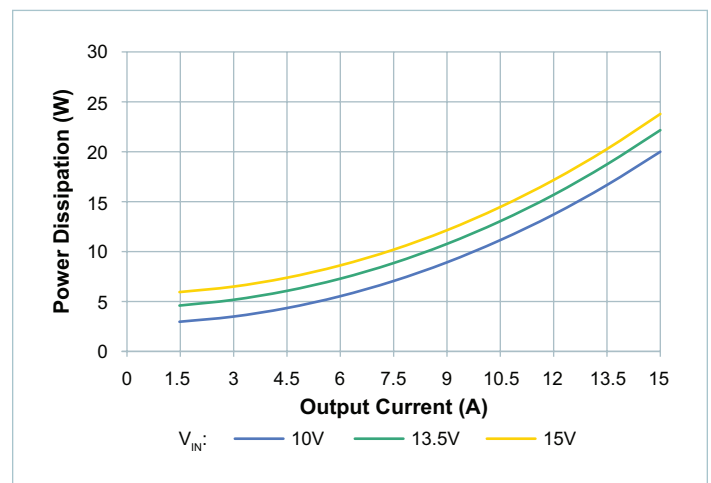

Figure 23 — Power dissipation at $T_{CASE} = 25^{\circ}C$

Application Characteristics, Step-Up Operation (Cont.)

Temperature controlled via top-side cold plate, unless otherwise noted. All data presented in this section are collected from units operating in step-up mode, processing power from low-voltage side to high-voltage side. See associated figures for general trend data.

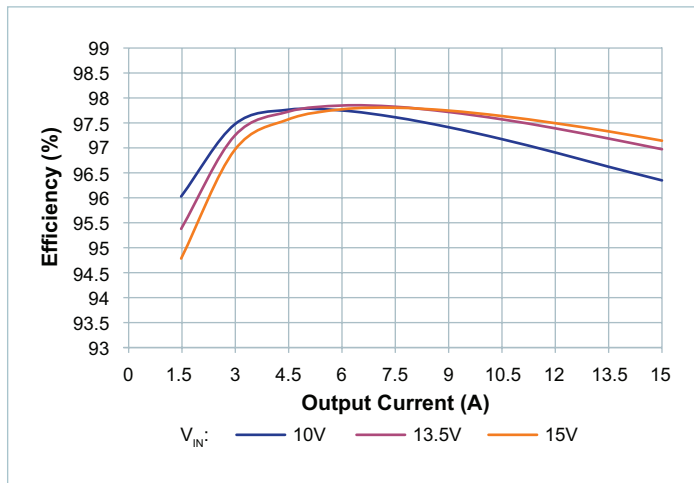

Figure 24 — Efficiency at $T_{CASE} = 85^{\circ}C$

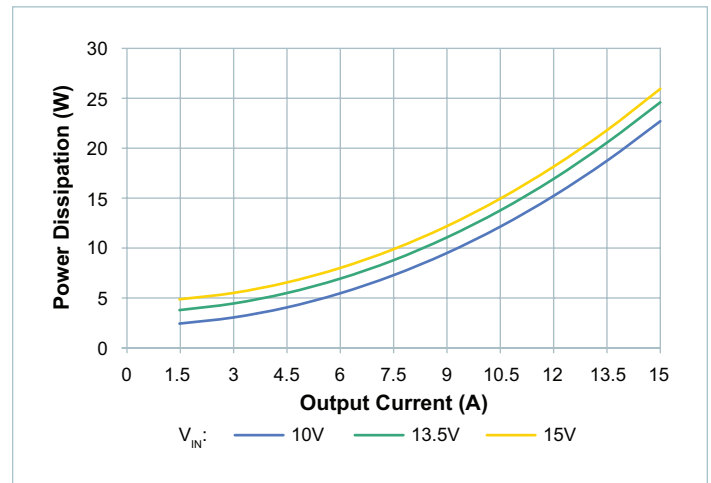

Figure 25 — Power dissipation at $T_{CASE} = 85^{\circ}C$

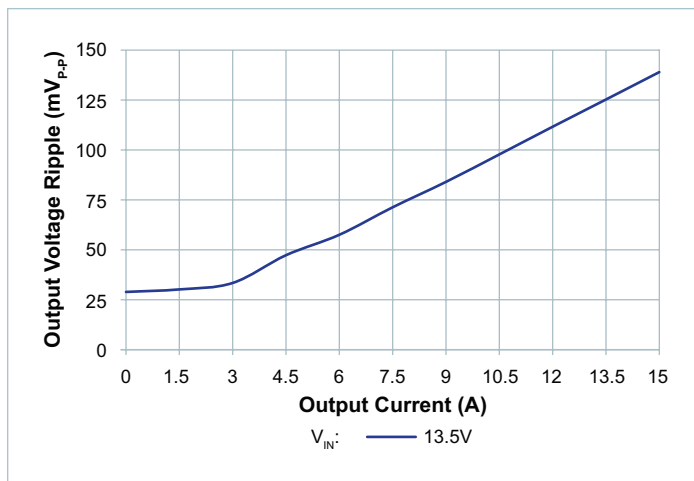

Figure 26 — $V_{HI_OUT_PP}$ vs. I_{HI_DC} ; no external $C_{HI_OUT_EXT}$. Board-mounted module, scope setting: 20MHz analog BW

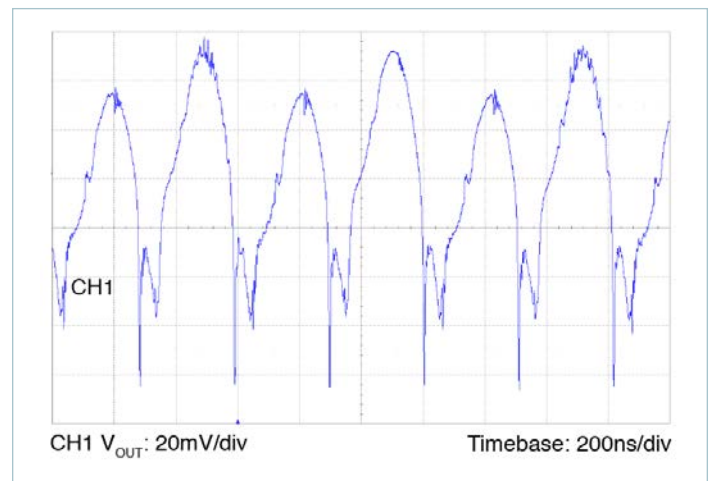

Figure 27 — Full-load high-side output voltage ripple, $1000\mu F C_{LO_IN_EXT}$; no external $C_{HI_OUT_EXT}$. Board-mounted module, scope setting: 20MHz analog BW

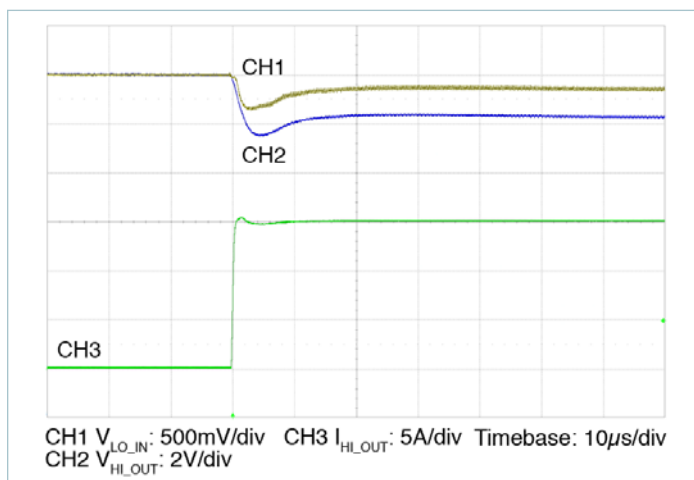

Figure 28 — 0 – 15A transient response: $C_{LO_IN_EXT} = 1000\mu F$, no external $C_{HI_OUT_EXT}$

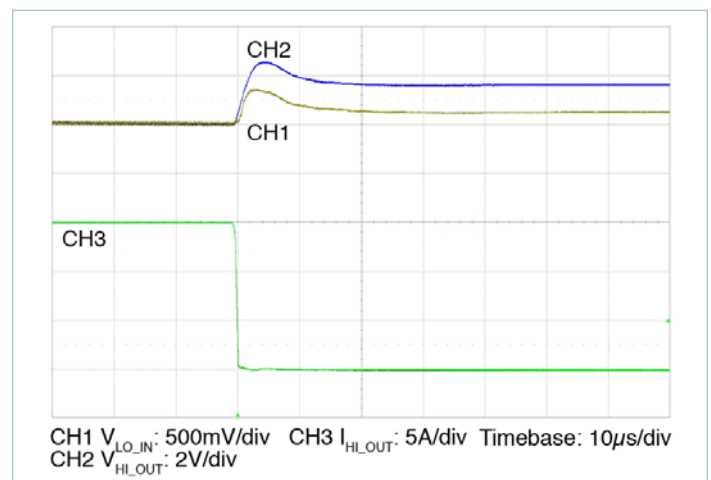

Figure 29 — 15 – 0A transient response: $C_{LO_IN_EXT} = 1000\mu F$, no external $C_{HI_OUT_EXT}$

Application Characteristics, Step-Up Operation (Cont.)

Temperature controlled via top-side cold plate, unless otherwise noted. All data presented in this section are collected from units operating in step-up mode, processing power from low-voltage side to high-voltage side. See associated figures for general trend data.

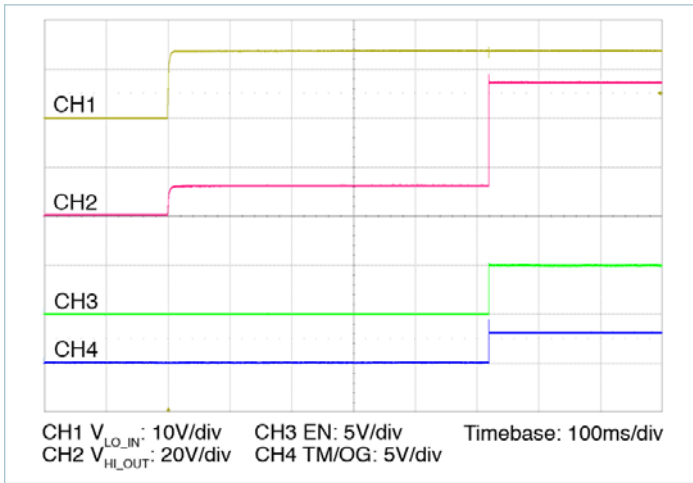

Figure 30 — Start up from application of $V_{LO_DC} = 13.5V$, $C_{HI_OUT_EXT} = 68\mu F$, no load

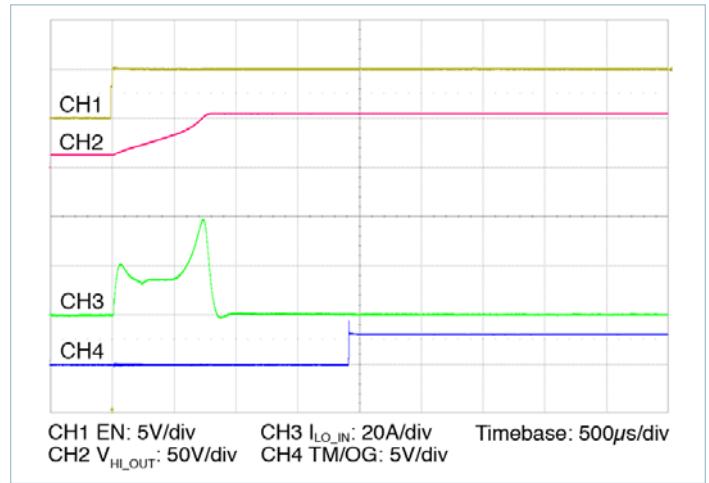

Figure 31 — Start up from application of EN with pre-applied $V_{LO_DC} = 13.5V$, $C_{HI_OUT_EXT} = 68\mu F$, no load

Signal Terminal Descriptions

Enable Control (EN)

The EN terminal enables and disables the NBM. When held low, the NBM is disabled. When allowed to float with an impedance to PGND greater than 60kΩ, the module will start. In an array of NBM modules, EN terminals should be interconnected to synchronize start up. The NBM modules will start simultaneously when enabled.

The EN terminal is capable of being either driven high by an external open collector or open drain logic signal or internal pull up to 5V (operating). EN terminal outputs 5V during normal operation. Note that EN terminal does not have current sink capability. Therefore, in an array configuration of multiple NBMs, the EN terminal of one unit is not capable of disabling other modules in the event of a fault condition. The EN terminal must not be driven high by directly applying an external voltage.

Temperature Monitor and Output Good (TM / OG)

The TM / OG terminal provides temperature monitoring and power good functionalities. It can be used to accomplish the following two functions.

■ Output Good flag

This terminal will be internally held low (0V) by an internal pull-down FET until the start up has completed. When the output voltage is in a steady state condition after the completion of the soft start, it will internally be released and can be used as a "Ready to process full load current" flag.

This signal can be used to drive logic circuitry downstream for delayed enable or connection of the load. It can also be used as "Fault flag", as the terminal is pulled low internally when a fault is detected.

■ Monitor the control IC temperature

This terminal provides a voltage proportional to the absolute temperature of the converter control IC. It monitors the internal junction temperature of the controller IC within an accuracy of ±5°C. It has a room temperature set point of ~3.0V and an approximate gain of 10mV/°C. The temperature in Kelvin is equal to the voltage on the TM terminal scaled by 100. (i.e., 3.0V = 300K = 27°C).

The following equation can be used to calculate the equivalent TM voltage in Volts for a given junction temperature (T_j) in °C.

$$TM(V) = \frac{1}{100} (T_j) + 2.73$$

The following equation can be used to calculate the junction temperature (T_j) in °C for a given TM voltage in Volts.

$$TM(^{\circ}C) = (TM - 2.73) \cdot 100$$

Start Up and Bidirectional Operation

The NBM2317S60E1560T0R is capable of start up in both directions of operation (step-up and step-down) once the applied voltage is greater than the undervoltage lockout threshold.

The non-isolated bus converter module is fully bidirectional. Once the unit is enabled, the NBM2317S60E1560T0R will operate in step-up mode, transferring energy from low side to the high side, whenever the low-side voltage exceeds $V_{HI} \cdot K$. The NBM2317S60E1560T0R module will operate in step-down mode, transferring energy from high side to the low side, whenever the high-side voltage exceeds V_{LO} / K .

Loading must be delayed until completion of start up. The output good (OG) signal can be used to determine when the start-up has completed and the load can be safely enabled. A load must not be present on the +V_{HI} terminal if the powertrain is not actively switching and +V_{LO} is present: remove any HI-side load prior to disabling the module.

Conduction from LO to HI side through powertrain MOSFET body diodes will occur if the unit stops switching while a load is present on the HI side and LO-side voltage (+V_{LO}) is present. In other words, if the powertrain is disabled through EN terminal or by any fault detection and LO-side voltage (+V_{LO}) is present, then a voltage equal to +V_{LO} minus the body diode drops will appear on the HI side, see Figure 32. Note that in this condition the NBM does not have a current-limiting mechanism from +V_{LO} to +V_{HI}. The built-in short-circuit fault shut down will stop the powertrain switching in case of a fault on the HI side; however external circuitry will be needed to limit the fault current and remove faults.

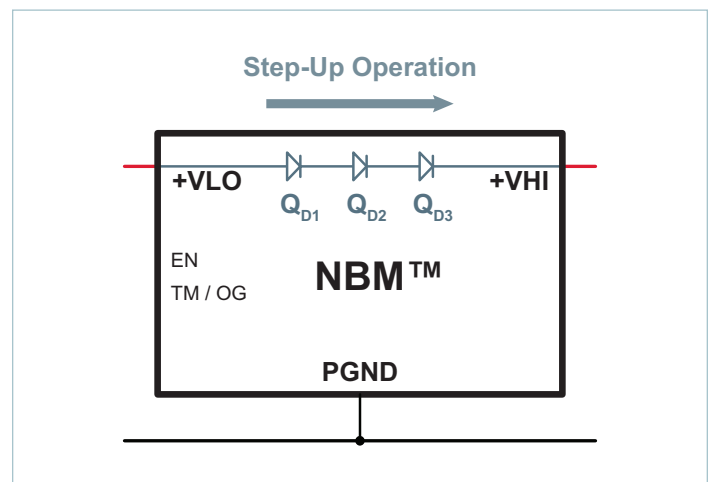

Figure 32 — Conduction path through MOSFET body diodes under disabled or fault conditions

Q_{D1} , Q_{D2} , Q_{D3} are the internal power MOSFET drain-source body diodes. The voltage drop across each diode is 1.1V, and any current conduction through the diodes is not recommended.

SM-ChiP™ NBM

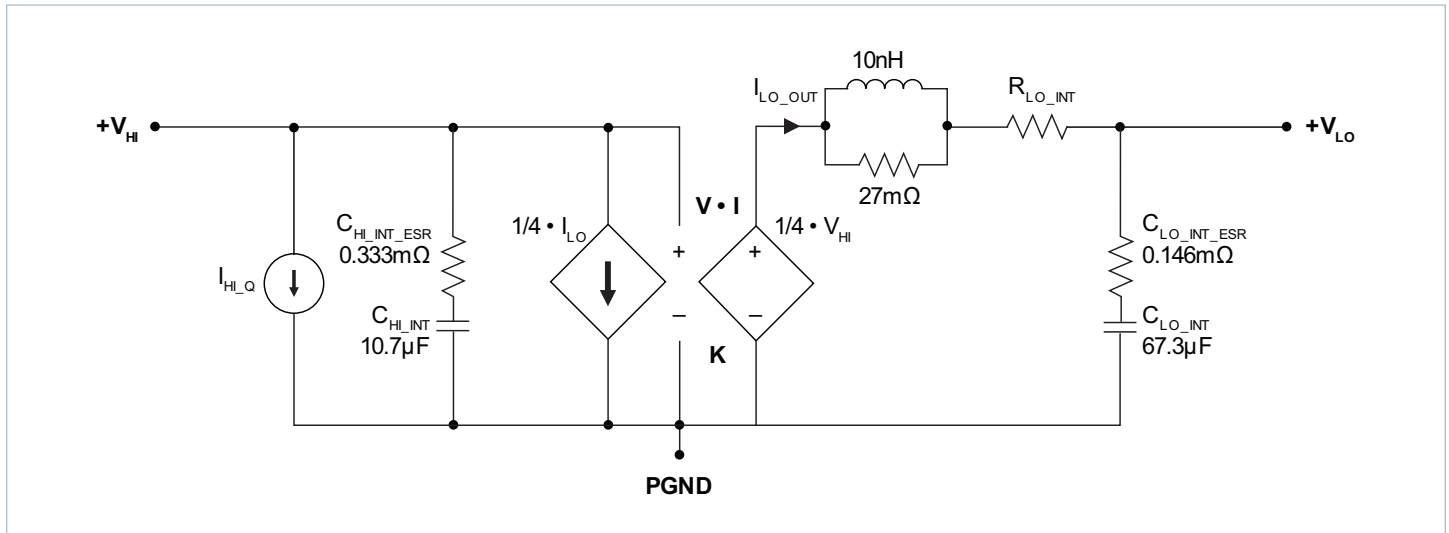

Figure 33 — NBM AC model

The NBM uses a high-frequency resonant tank to move energy from high-voltage side to low-voltage side and vice versa. The resonant LC tank, operated at high frequency, is amplitude modulated as a function of the high-side voltage and the low-side current. A small amount of capacitance embedded in the high-voltage side and low-voltage side stages of the module is sufficient for full functionality and is key to achieving high power density.

The NBM2317S60E1560T0R can be simplified into the model shown in Figure 33.

At no load:

$$V_{LO} = V_{HI} \cdot K \tag{1}$$

K represents the “turns ratio” of the NBM. Rearranging Eq (1):

$$K = \frac{V_{LO}}{V_{HI}} \tag{2}$$

In the presence of a load, V_{LO} is represented by:

$$V_{LO} = V_{HI} \cdot K - I_{LO} \cdot R_{LO} \tag{3}$$

and I_{LO} is represented by:

$$I_{LO} = \frac{I_{HI} - I_{HI_Q}}{K} \tag{4}$$

R_{LO} represents the impedance of the NBM, and is a function of the R_{DS_ON} of the high-side and low-side MOSFETs and the winding resistance of the power transformer. I_{HI_Q} represents the quiescent current of the NBM controller, gate drive circuitry and core losses.

The effective DC voltage transformer action provides additional interesting attributes. Assuming that $R_{LO} = 0\Omega$ and $I_{HI_Q} = 0A$, Equation 3 now becomes Equation 1 and is essentially load independent, resistor R is now placed in series with V_{HI} .

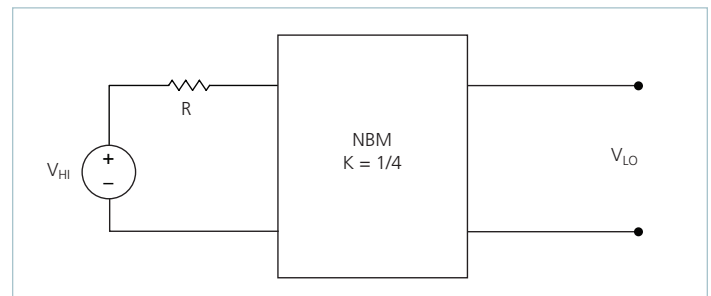

Figure 34 — K = 1/4 NBM with series high-side resistor

The relationship between V_{HI} and V_{LO} becomes:

$$V_{LO} = (V_{HI} - I_{HI} \cdot R) \cdot K \tag{5}$$

Substituting the simplified version of Equation 4 (I_{HI_Q} is assumed = 0A) into Equation 5 yields:

$$V_{LO} = V_{HI} \cdot K - I_{LO} \cdot R \cdot K^2 \tag{6}$$

This is similar in form to Equation 3, where R_{LO} is used to represent the characteristic impedance of the NBM. However, in this case a real resistor, R, on the high side of the NBM is effectively scaled by K^2 with respect to the low side.

Assuming that $R = 1\Omega$, the effective R as seen from the low side is 62.5mΩ, with $K = 1/4$.

A similar exercise can be performed with the addition of a capacitor or shunt impedance at the high-voltage side of the NBM. A switch in series with V_{HI} is added to the circuit. This is depicted in Figure 35.

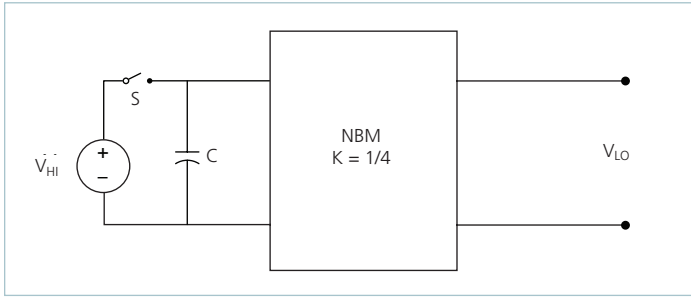

Figure 35 — NBM with high-side capacitor

A change in V_{HI} with the switch closed would result in a change in capacitor current according to the following equation:

$$I_C(t) = C \frac{dV_{HI}}{dt} \quad (7)$$

Assume that with the capacitor charged to V_{HI} , the switch is opened and the capacitor is discharged through the idealized NBM. In this case,

$$I_C = I_{LO} \cdot K \quad (8)$$

substituting Equation 1 and 8 into Equation 7 reveals:

$$I_{LO}(t) = \frac{C}{K^2} \cdot \frac{dV_{LO}}{dt} \quad (9)$$

The equation in terms of the low side has yielded a K^2 scaling factor for C , specified in the denominator of the equation.

A K factor less than unity results in an effectively larger capacitance on the low side when expressed in terms of the high side. With $K = 1/4$ as shown in Figure 36, $C = 1\mu\text{F}$ would appear as $C = 16\mu\text{F}$ when viewed from the low side.

Low impedance is a key requirement for powering a high-current, low-voltage load efficiently. A switching regulation stage should have minimal impedance while simultaneously providing appropriate filtering for any switched current. The use of a NBM between the regulation stage and the point of load provides a dual benefit of scaling down series impedance leading back to the source and scaling up shunt capacitance or energy storage as a function of its K factor squared. However, these benefits are not achieved if the series impedance of the NBM is too high. The impedance of the NBM must be low, i.e., well beyond the crossover frequency of the system.

A solution for keeping the impedance of the NBM low involves switching at a high frequency. This enables the use of small magnetic components because magnetizing currents remain low. Small magnetics mean small path lengths for turns. Use of low loss core material at high frequencies also reduces core losses.

The two main terms of power loss in the NBM are:

- No load power dissipation (P_{HI_NL}): defined as the power used to power up the module with an enabled powertrain at no load.
- Resistive loss (P_{R_LO}): refers to the power loss across the NBM modeled as pure resistive impedance.

$$P_{DISSIPATED} = P_{HI_NL} + P_{R_LO} \quad (10)$$

Therefore,

$$P_{LO_OUT} = P_{HI_IN} - P_{DISSIPATED} = P_{HI_IN} - P_{HI_NL} - P_{R_LO} \quad (11)$$

The above relations can be combined to calculate the overall module efficiency:

$$\eta = \frac{P_{LO_OUT}}{P_{HI_IN}} = \frac{P_{HI_IN} - P_{HI_NL} - P_{R_LO}}{P_{HI_IN}} \quad (12)$$

$$= \frac{V_{HI} \cdot I_{HI} - P_{HI_NL} - (I_{LO})^2 \cdot R_{LO}}{V_{HI} \cdot I_{HI}}$$

$$= 1 - \left(\frac{P_{HI_NL} + (I_{LO})^2 \cdot R_{LO}}{V_{HI} \cdot I_{HI}} \right)$$

NBM Step-Down Operation Timing Diagram

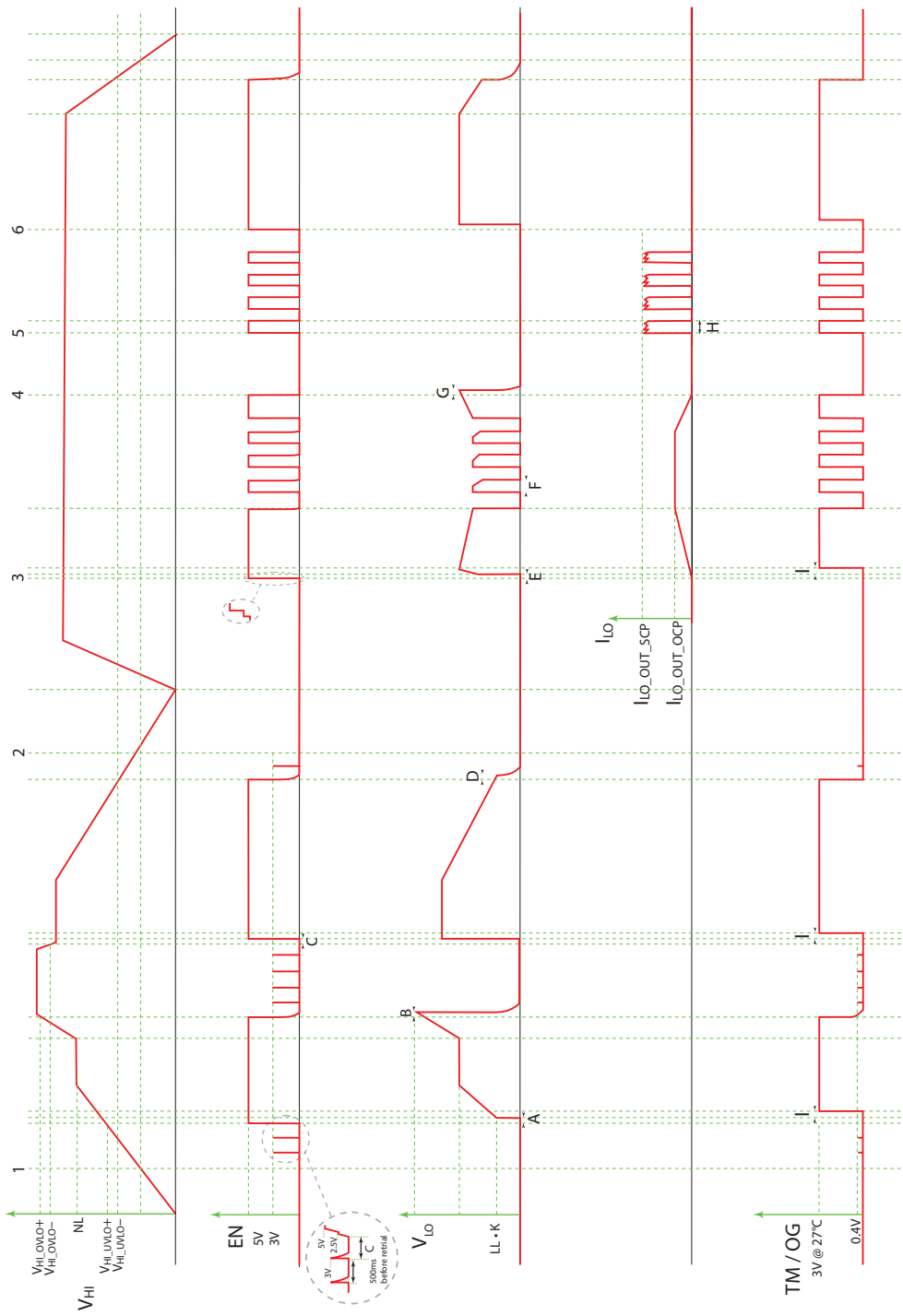

Notes:

- Timing and signal amplitudes are not to scale
- Error pulse width is load dependent

1: Controller start
 2: Controller turn off
 3: EN release
 4: EN pulled low
 5: EN released on low-side SC
 6: Low-side SC removed

A: $t_{\text{EN_LUVLO_DELAY}}$
 B: $t_{\text{HI_OVLO}}^*$
 C: $t_{\text{AUTO_RESTART}}$
 D: t_{UVLO}
 E: $t_{\text{EN_START}}$
 F: $t_{\text{LO_OUT_OCP}}$
 G: $t_{\text{EN_DIS}}$
 H: $t_{\text{LO_OUT_SCP}}^{**}$
 I: $t_{\text{TM/OG}}$

* Min value switching off
 ** From detection to powertrain shut down

NBM Step-Up Operation Timing Diagram

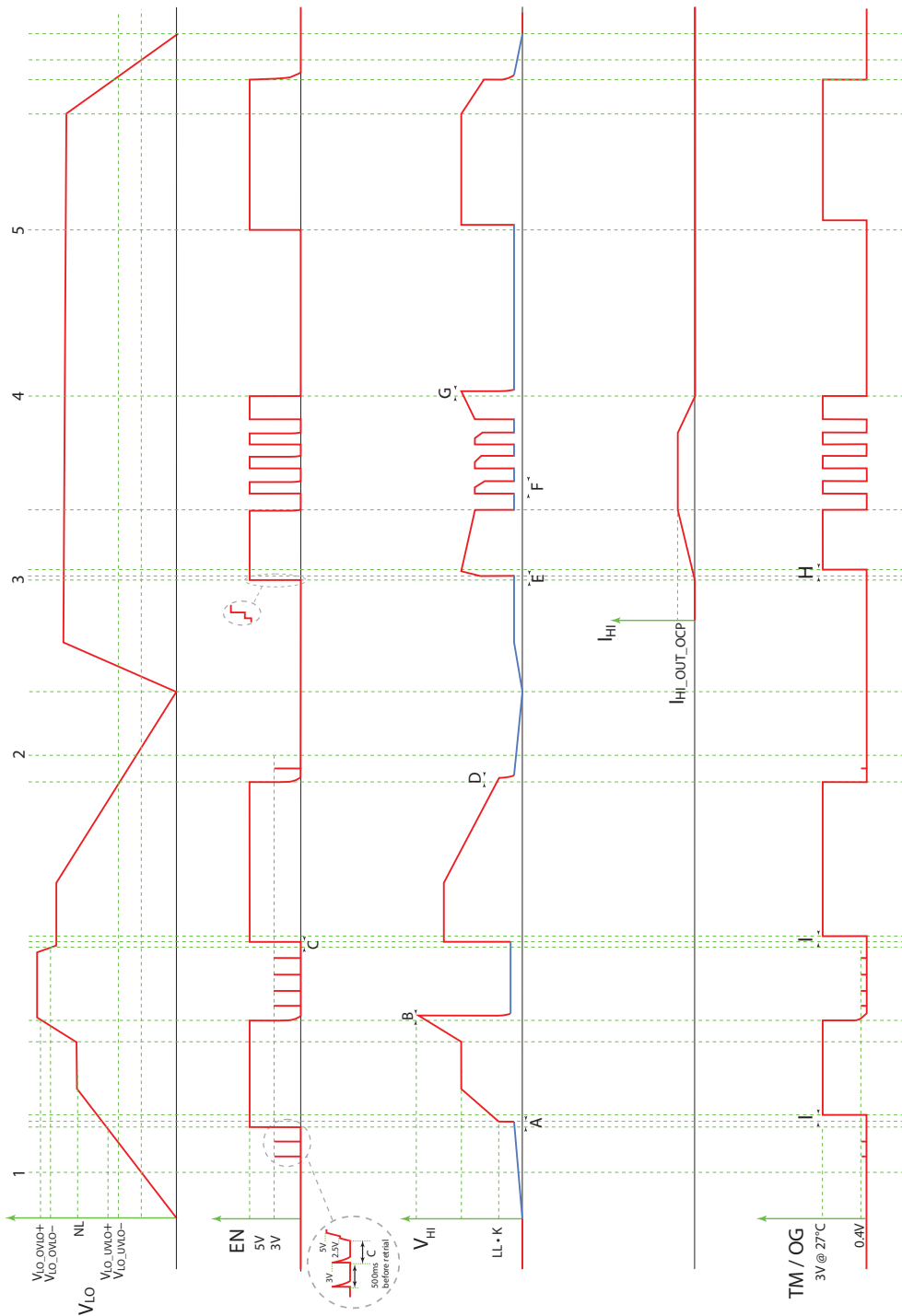

Notes:

- Timing and signal amplitudes are not to scale
- Error pulse width is load dependent
- Blue line: A conduction path from low side to high side exists through body diodes of powertrain MOSFET. When the powertrain is disabled and V_{Lo} present, a voltage equal to V_{Lo} minus the body diode drops will appear on the HI side.

1: Controller start
 2: Controller turn off
 3: EN release
 4: EN pulled low
 5: Thermal fault removed

A: $t_{LO_UVLO+_DELAY}$
 B: t_{LO_OVLO*}
 C: $t_{AUTO_RESTART}$
 D: t_{UVLO}
 E: t_{EN_START}
 F: $t_{HI_OUT_OCP}$
 G: t_{EN_DIS}
 H: $t_{TM/OG}$

* Min value switching off

Input and Output Filter Design

A major advantage of NBM systems versus conventional PWM converters is that the auto-transformer based NBM does not require external filtering to function properly. The resonant LC tank, operated at extreme high frequency, is amplitude modulated as a function of high-side voltage and low-side current and efficiently transfers charge through the auto-transformer. A small amount of capacitance embedded in the high-side and low-side stages of the module is sufficient for full functionality and is key to achieving power density.

This paradigm shift requires system design to carefully evaluate external filters in order to:

- **Guarantee low source impedance:**

To take full advantage of the NBM’s dynamic response, the impedance presented to its high-side terminals must be low from DC to approximately 5MHz. The connection of the non-isolated bus converter module to its power source should be implemented with minimal distribution inductance. In step-down operation, the interconnect inductance on the high side should not exceed 300nH; in step-up operation, the interconnect inductance on the low side should not exceed 20nH. If the interconnect inductance exceed these limits, the input side of the NBM should be bypassed with a RC damper or electrolytic capacitor to retain low source impedance and stable operation.

- **Further reduce high-side and/or low-side voltage ripple without sacrificing dynamic response:**

Given the wide bandwidth of the module, the source response is generally the limiting factor in the overall system response. Anomalies in the response of the high-side source will appear at the low side of the module multiplied by its K factor.

- **Protect the module from overvoltage transients imposed by the system that would exceed maximum ratings and induce stresses:**

The module high-side/low-side voltage ranges shall not be exceeded. An internal overvoltage lockout function prevents operation outside of the normal operating range.

Total load capacitance of the NBM module shall not exceed the specified maximum. Owing to the wide bandwidth and low low-side impedance of the module, low-frequency bypass capacitance and significant energy storage may be more densely and efficiently provided by adding capacitance at the high side of the module. At frequencies <500kHz the module appears as an impedance of R_{LO} between the source and load.

Within this frequency range, capacitance at the high side appears as effective capacitance on the low side per the relationship defined in Equation 13.

$$C_{LO_EXT} = \frac{C_{HI_EXT}}{K^2} \quad (13)$$

This enables a reduction in the size and number of capacitors used in a typical system.

Current Sharing

The performance of the NBM topology is based on efficient transfer of energy through a auto-transformer without the need of closed loop control. For this reason, the transfer characteristic can be approximated by an ideal auto-transformer with a positive temperature coefficient series resistance.

This type of characteristic is close to the impedance characteristic of a DC power distribution system both in dynamic (AC) behavior and for steady state (DC) operation.

When multiple NBMs of a given part number are connected in an array, they will inherently share the load current according to the equivalent impedance divider that the system implements from the power source to the point of load. Ensuring equal current sharing among modules requires that NBM array impedances be matched.

Some general recommendations to achieve matched array impedances include:

- Dedicate common copper planes within the PCB to deliver and return the current to the modules.
- Provide as symmetric a PCB layout as possible among modules
- A dedicated input filter for each NBM in an array is recommended to prevent circulating currents.

For further details see:

[AN:016 Using BCM Bus Converters in High Power Arrays](#)

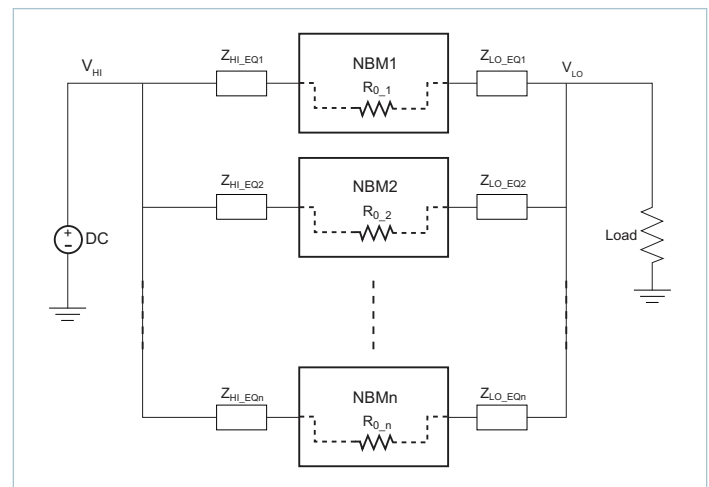

Figure 36 — NBM parallel array

Input Fuse Selection

In order to provide flexibility in configuring power systems, SM-ChiP modules are not internally fused. Input line fusing of SM-ChiP products is recommended at the system level to provide thermal protection in case of catastrophic failure.

An input fuse is required to meet safety agency conditions of acceptability. A 20A input fuse (Littelfuse® Nano2® 456 Series) is required in step-down operation to comply with safety agency conditions of acceptability. Always ascertain and observe the safety, regulatory or other agency specifications that apply to your specific application.

Thermal Considerations

The SM-ChiP™ module provides a high degree of flexibility in that it presents several pathways to remove heat from the internal power dissipating components. Heat may be removed from the top surface, the bottom surface, the power terminals and the signal terminals. The extent to which these surfaces are cooled is a key component in determining the maximum current that is available from an SM-ChiP, as can be seen from Figures 2 and 3.

Since the SM-ChiP has a maximum internal temperature rating, it is necessary to estimate this internal temperature based on a system-level thermal solution. Given that there are many pathways to remove heat from the SM-ChiP, it is helpful to simplify the thermal solution into a roughly equivalent circuit where power dissipation is modeled as a current source, isothermal surface temperatures are represented as voltage sources and the thermal resistances are represented as resistors.

Figure 37(a) shows the “thermal circuit” for a NBM2317 SM-ChiP in two-sided cooling application, where the product is cooled through the PCB at the bottom and a heat sink at the top. In this case, the NBM power dissipation is $P_{DISSIPATION}$ and the top and bottom (heat sink and PCB) surface temperatures are represented as $T_{TOP_HEAT_SINK}$ and T_{PCB} . This thermal system can now be very easily analyzed as an electrical network with simple resistors, voltage sources, and a current source. The results of the simulation provide an estimate of heat flow through the various dissipation pathways as well as internal temperature.

Figure 37(b) shows the thermal model for an application with single-side cooling, where the heat is dissipated through the PCB only. In this case, the heat flow path to the top heat sink is removed; the top of the package now contributes to the cooling into the PCB via the package metalization (i.e., the θ_{PGND_TOP} and $\theta_{PGND_TOP_BOTTOM}$ resistances are in series between the maximum internal temperature point and the PCB temperature).

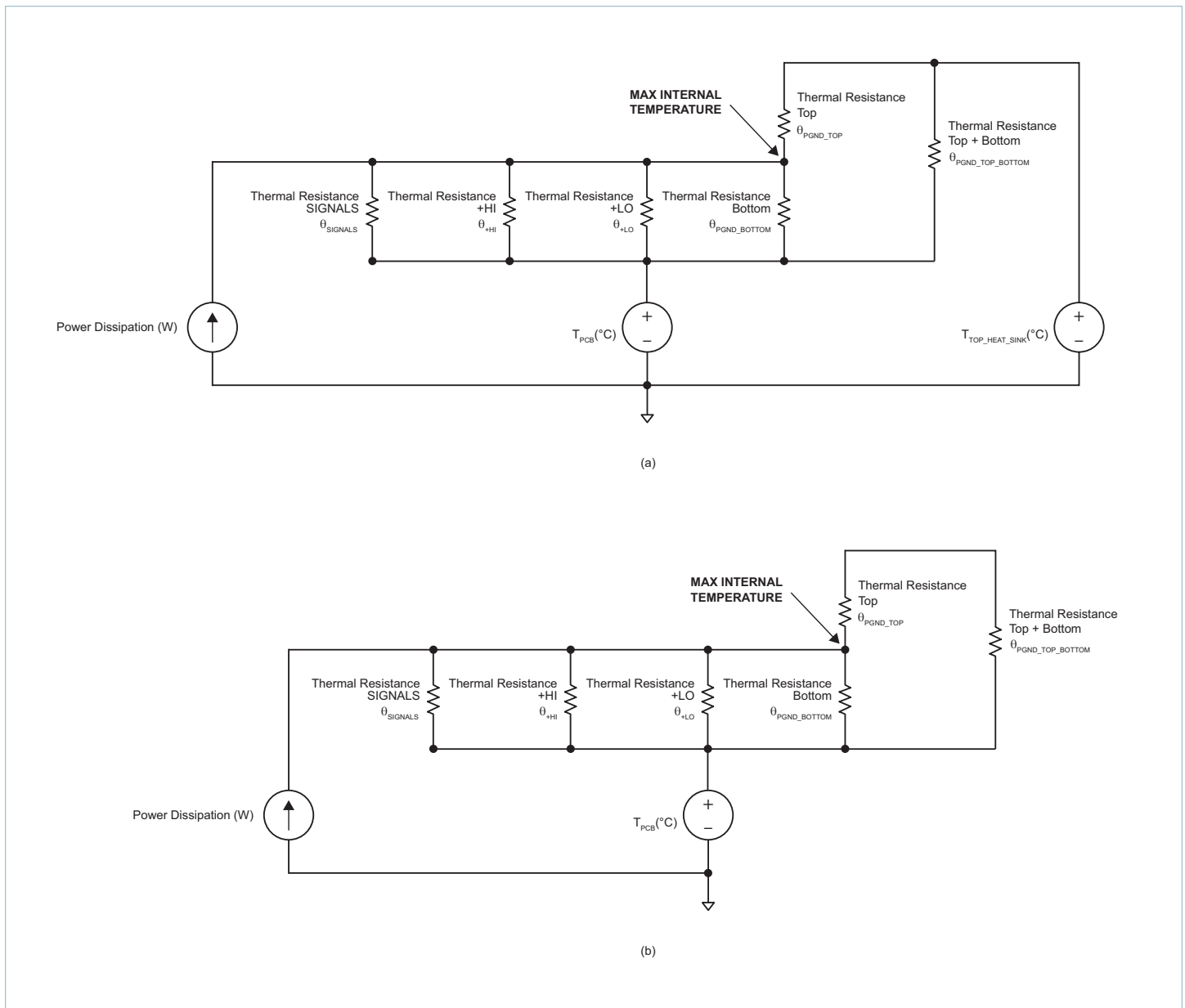

Figure 37 — NBM2317S60E1560T0R two-sided cooling thermal model (a) and bottom-side cooling only (through PCB) thermal model (b).

Thermal Considerations (Cont.)

Symbol	Thermal Impedance (°C / W)	Definition of Estimated Thermal Resistance
θ_{SIGNALS}	210	from the hottest component junction inside the NBM to the circuit board it is mounted on at SIGNALS
$\theta_{\text{+VHI}}$	82	from the hottest component junction inside the NBM to the circuit board it is mounted on at +VHI
$\theta_{\text{+VLO}}$	15	from the hottest component junction inside the NBM to the circuit board it is mounted on at +VLO
$\theta_{\text{PGND_BOTTOM}}$	2.7	from the hottest component junction inside the NBM to the circuit board it is mounted on at PGND_BOTTOM
$\theta_{\text{PGND_TOP}}$	2.5	from the hottest component junction inside the NBM to the circuit board it is mounted on at PGND_TOP
$\theta_{\text{PGND_TOP_BOTTOM}}$	5.4	between PGND_TOP and PGND_BOTTOM

Table 1 — Thermal impedance

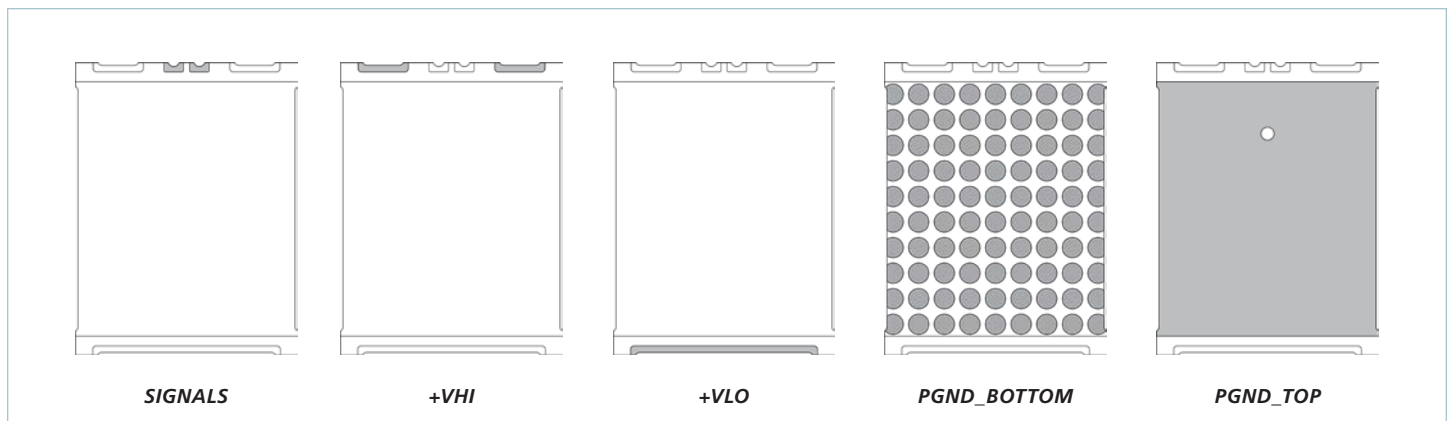
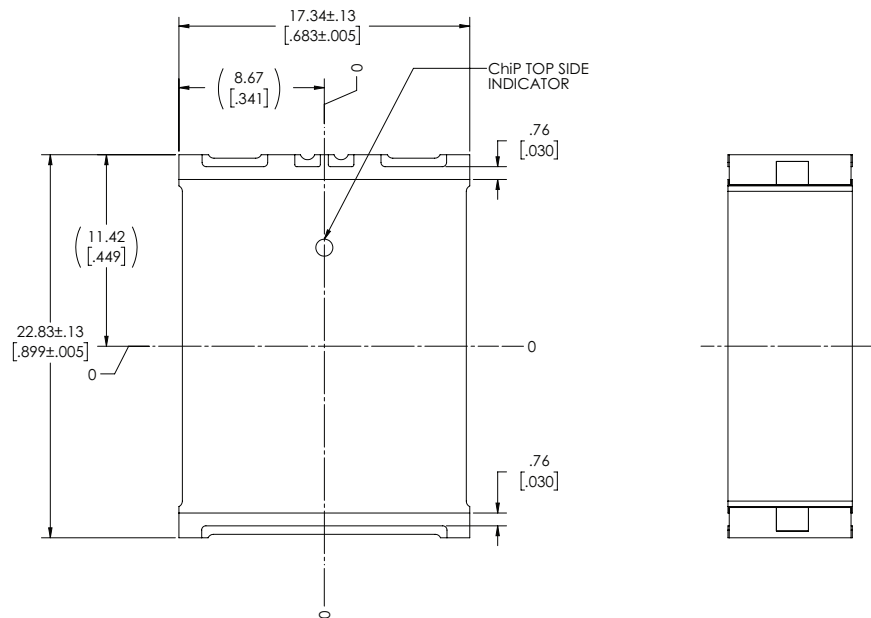

Figure 38 — Thermal model boundary conditions; area defined as shaded

NBM Package Drawing Top & Side View

2317 NBM TC3

(Reference DWG # 45810 Rev 2)



**TOP VIEW
(COMPONENT SIDE)**

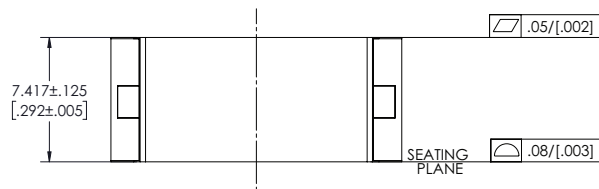

- NOTES:
 1- UNLESS OTHERWISE SPECIFIED DIMENSIONS ARE MM [INCH]
 2- TOLERANCES ARE:
 DECIMALS
 X.XX [X.XX] = ±0.25 [0.01]
 X.XXX [X.XXX] = ±0.127 [0.005]
 ANGLES = ±1°

NBM Package Drawing Bottom View

2317 NBM TC3
(Reference DWG # 45810 Rev 2)

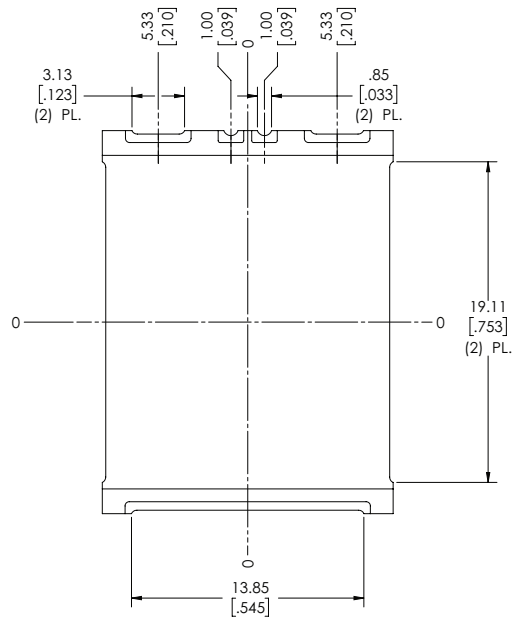

BOTTOM VIEW

NBM Recommended Land Pattern (Component Side)

2317 NBM TC3
 (Reference DWG # 45810 Rev 2)

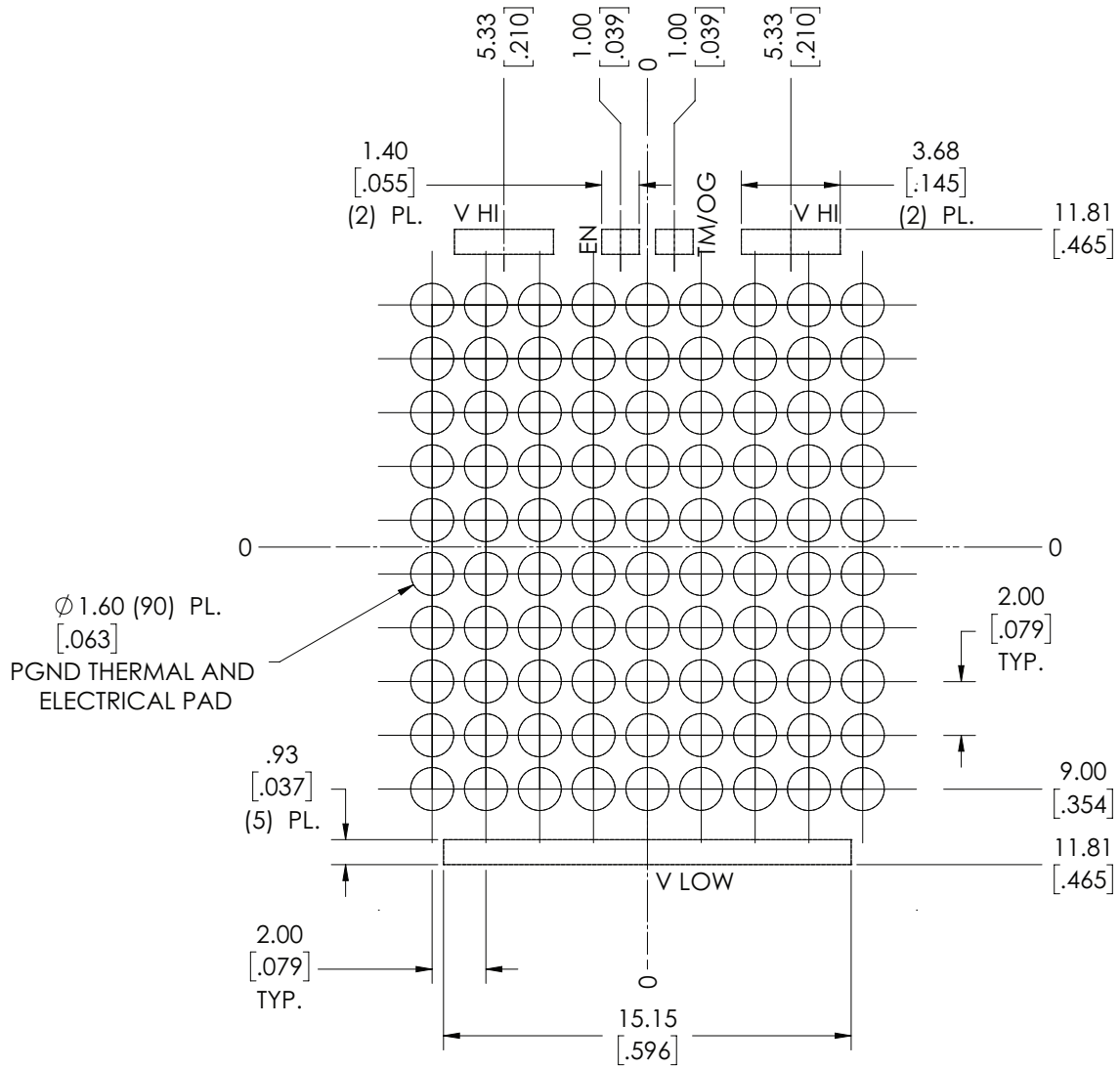

RECOMMENDED LAND PATTERN
 (COMPONENT SIDE)

Revision History

Revision	Date	Description	Page Number(s)
1.0	08/27/18	Initial release	n/a
1.1	12/18/18	Updated features & benefits Updated specifications and performance characteristics	1 5 – 19
1.2	01/29/19	Updated specified electrical operating area Updated TM/OG characteristics Updated output good flag description	10 11 21
1.3	06/26/19	Updated electrical specifications Updated TM/OG signal characteristics Corrected height specifications to match mechanical drawing	6, 8 11 20
1.4	11/06/19	Typo correction to ESR values in AC model	22
1.5	09/02/20	Changed product voltage ratings to $V_{HI} = 40 - 60V$ and $V_{LO} = 10 - 15V$ Added exterior package plating specification	1, 6, 7, 8, 10, 14, 15, 17, 18 20
1.6	02/22/21	Added TÜV agency approval Implemented formatting adjustments Revised application diagrams Revised start up and bidirectional operation, input fuse selection Updated outline drawing	1, 4 1, 3, 4, 9, 20, 21, 24 2 17, 22 25 – 27
1.7	04/20/21	Updated product image Updated electrical specifications	1 5, 7
1.8	07/16/21	Corrected absolute max rating for +VLO to PGND	4

Note: pages removed in Rev 1.6

Vicor's comprehensive line of power solutions includes high density AC-DC and DC-DC modules and accessory components, fully configurable AC-DC and DC-DC power supplies, and complete custom power systems.

Information furnished by Vicor is believed to be accurate and reliable. However, no responsibility is assumed by Vicor for its use. Vicor makes no representations or warranties with respect to the accuracy or completeness of the contents of this publication. Vicor reserves the right to make changes to any products, specifications, and product descriptions at any time without notice. Information published by Vicor has been checked and is believed to be accurate at the time it was printed; however, Vicor assumes no responsibility for inaccuracies. Testing and other quality controls are used to the extent Vicor deems necessary to support Vicor's product warranty. Except where mandated by government requirements, testing of all parameters of each product is not necessarily performed.

Specifications are subject to change without notice.

Visit <http://www.vicorpower.com/NBM-Non-isolated-Bus-Converter-Module> for the latest product information.

Vicor's Standard Terms and Conditions and Product Warranty

All sales are subject to Vicor's Standard Terms and Conditions of Sale, and Product Warranty which are available on Vicor's webpage (<http://www.vicorpower.com/termsconditionswarranty>) or upon request.

Life Support Policy

VICOR'S PRODUCTS ARE NOT AUTHORIZED FOR USE AS CRITICAL COMPONENTS IN LIFE SUPPORT DEVICES OR SYSTEMS WITHOUT THE EXPRESS PRIOR WRITTEN APPROVAL OF THE CHIEF EXECUTIVE OFFICER AND GENERAL COUNSEL OF VICOR CORPORATION. As used herein, life support devices or systems are devices which (a) are intended for surgical implant into the body, or (b) support or sustain life and whose failure to perform when properly used in accordance with instructions for use provided in the labeling can be reasonably expected to result in a significant injury to the user. A critical component is any component in a life support device or system whose failure to perform can be reasonably expected to cause the failure of the life support device or system or to affect its safety or effectiveness. Per Vicor Terms and Conditions of Sale, the user of Vicor products and components in life support applications assumes all risks of such use and indemnifies Vicor against all liability and damages.

Intellectual Property Notice

Vicor and its subsidiaries own Intellectual Property (including issued U.S. and Foreign Patents and pending patent applications) relating to the products described in this data sheet. No license, whether express, implied, or arising by estoppel or otherwise, to any intellectual property rights is granted by this document. Interested parties should contact Vicor's Intellectual Property Department.

The products described on this data sheet are protected by the following U.S. Patent Numbers:

6,911,848; 6,930,893; 6,934,166; 7,145,786; 7,782,639; 8,427,269; 9,166,481; 9,516,761; 10,199,950; 10,205,381; 10,454,361; 10,594,223; 10,658,923; 10,951,113; and for use under 6,975,098 and 6,984,965.

Contact Us: <http://www.vicorpower.com/contact-us>

Vicor Corporation
25 Frontage Road
Andover, MA, USA 01810
Tel: 800-735-6200
Fax: 978-475-6715
www.vicorpower.com

email

Customer Service: custserv@vicorpower.com
Technical Support: apps@vicorpower.com

X-ON Electronics

Largest Supplier of Electrical and Electronic Components

Click to view similar products for [Non-Isolated DC/DC Converters](#) category:

Click to view products by [Vicor](#) manufacturer:

Other Similar products are found below :

[PSR152.5-7IR](#) [APTH003A0X-SRZ](#) [SPM1004-3V3C](#) [R-785.0-05](#) [10E24-P15-10PPM](#) [1E24-P4-25PPM-SHV-5KV](#) [PROPOWER-3.3V](#)
[MYGTM01210BZN](#) [40C24-N250-I5-H](#) [40A24-P30-E](#) [3V12-P0.8](#) [10C24-N250-I10-AQ-DA](#) [4AA24-P20-M-H](#) [3V12-N0.8](#) [3V24-P1](#) [3V24-](#)
[N1](#) [BMR4672010/001](#) [BMR4652010/001](#) [6AA24-P30-I5-M](#) [6AA24-N30-I5-M](#) [BM2P101X-Z](#) [35A24-P30](#) [2.5M24-P1](#) [PTV03010WAD](#)
[PTV05020WAH](#) [PTV12010LAH](#) [PTV12020WAD](#) [R-7212D](#) [R-7212P](#) [R-78AA15-0.5SMD](#) [R-78AA5.0-1.0SMD](#) [30A24-N15-E](#) [10A12-P4-](#)
[M](#) [10C24-N250-I5](#) [10C24-P125](#) [10C24-P250-I5](#) [6A24-P20-I10-F-M-25PPM](#) [1A24-P30-F-M-C](#) [TSR 1-24150SM](#) [1/2AA24-N30-I10](#) [1C24-](#)
[N125](#) [12C24-N250](#) [V7806-1500](#) [PTV12020LAH](#) [PTV05010WAH](#) [PTN04050CAZT](#) [PTH12020WAD](#) [PTH12020LAS](#) [PTH05050YAH](#)
[PTH05T210WAH](#)