

VIIYONG		GUANGDONG VIIYONG ELECTRONIC TECHNOLOGY CO., LTD.		Page number	1 / 14
File name	Multi-layer Ceramic Chip Capacitor		File type	Product Specification	
Issued No.	SGVX-CCF202011	Confidentiality level	External public documents	Date	2020-11-03

1、 Purpose versus Application characteristics:

The specifications are applicable to Multi-layer Ceramic Chip Capacitor (MLCC):

■ Universal; Automotive Grade;

2、 The term / Definition: :

2.1 Structural design classification: ■General; Ultra Micro; High Capacitance; High-Q;

High-voltage

2.2 Chip Size: 01005、 0201、 ■0402、 ■0603、 ■0805、 ■1206、 ____ (Others);

2.3 Capacitance range: 0.1pF~1μF;

2.4 Voltage range: 6.3V~ 50V;

2.5 Type of Dielectrics: ■C0G、 ■X7R、 ■X5R、 ■Y5V、 ■X7S、 ____ (Others);

ADD: Viiyong Hi-Tech Park, No.1 Chuangye 2nd Road, Shuangdong Sub-district, 527200, Luoding City, Guangdong Province, P. R. China

Postcode: 527200 TEL: 0766-3810639 FAX: 0766-3810639

Mark: The product specification is only for reference of design selection, not used as the basis for delivery

VIIYONG GUANGDONG VIIYONG ELECTRONIC TECHNOLOGY CO., LTD.		Page number	2 / 14
File name	Multi-layer Ceramic Chip Capacitor	File type	Product Specification
Issued No.	SGVX-CCF202011	Confidentiality level	External public documents
		Date	2020-11-03

3、Part Number System:

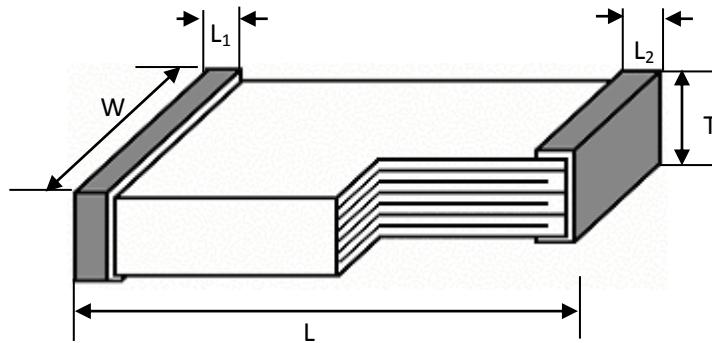
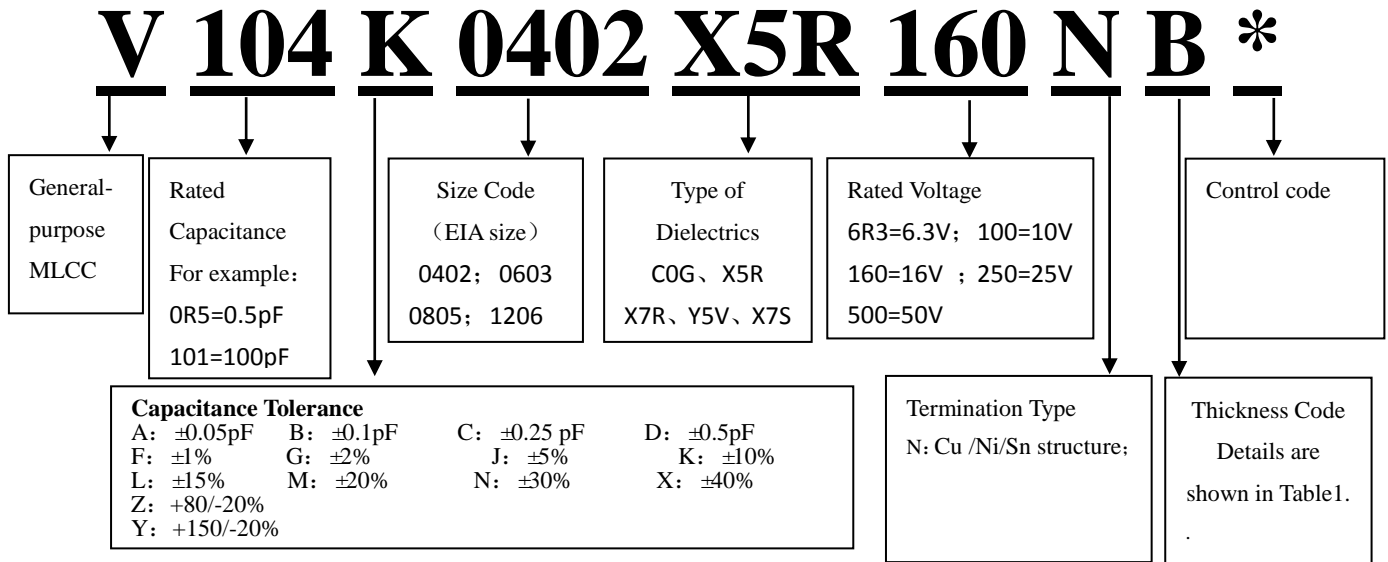

Figure 1 Configuration and Dimension of MLCC

Table 1 Dimension of MLCC (Unit: mm)

Size	Length (L)	Width (W)	Width of Termination (L1、L2)	Thickness (T)	Thickness code
0402	1.00±0.05	0.50±0.05	0.10~0.35	0.50±0.05	B
	1.00 ^{+0.15} _{-0.05}	0.50 ^{+0.13} _{-0.05}	0.10~0.35	0.50 ^{+0.13} _{-0.05}	N
0603	1.60±0.10	0.80±0.10	0.15~0.60	0.80±0.10	D
0805	2.00±0.20	1.25±0.20	0.20~0.75	0.85 ^{+0.15} _{-0.35}	Y
	2.00 ^{+0.20} _{-0.30}	1.25 ^{+0.20} _{-0.30}	0.20~0.75	1.25 ^{+0.20} _{-0.30}	H
1206	3.20±0.20	1.60±0.20	0.25~0.75	0.85 ^{+0.15} _{-0.35}	Y
	3.20±0.20	1.60±0.20	0.25~0.75	1.15±0.20	O
	3.20±0.20	1.60±0.20	0.25~0.75	1.60±0.20	L

File name	Multi-layer Ceramic Chip Capacitor			File type	Product Specification
Issued No.	SGVX-CCF202011	Confidentiality level	External public documents	Date	2020-11-03

Table 2 Type of dielectrics

Type of Dielectrics	Operating Temperature Range	Temperature Coefficient or Characteristic
NP0	-55°C ~ +125°C	C0G: 0±30ppm/°C
		C0H: 0±60ppm/°C
X7R	-55°C ~ +125°C	±15%
X5R	-55°C ~ +85°C	±15%
Y5V	-30°C ~ +85°C	+22/-82%
X7S	-55°C ~ +125°C	±22%

Table 3 Rated Voltage and Rated Capacitance

Size	Rate voltage /U _R	Capacitance					Thickness code
		C0G	X7R	X5R	Y5V	X7S	
0402	50V	0.1pF~1.0nF	100pF~68nF	100pF~100nF	100pF~68nF	—	B
		360pF~1.0nF	22nF~68nF	22nF~100nF	22nF~68nF	—	N
		—	100nF	—	—	—	C
	35V	—	100nF	100nF	—	—	B
	25V	0.1pF~1.0nF	22nF~100nF	10nF~220nF	10nF~68nF	—	B
		470pF~1.0nF	100nF	82nF~220nF	100nF	—	N
	16V	—	56nF~100nF	47nF~470nF	47nF~150nF	—	B
		—	—	120nF~470nF	150nF~220nF	—	N
	10V	—	—	100nF~470nF	100nF	120nF~220nF	B
		—	—	100nF~470nF	150nF~220nF	120nF~470nF	N
6.3V	—	—	100nF~470nF	—	120nF~470nF	B	
6.3V	—	—	100nF~470nF	220nF	—	N	
0603	50V	1pF~2.2nF	220pF~100nF	220pF~100nF	220pF~220nF	—	D
	25V	2.7nF~3.9nF	100nF~390nF	100nF~220nF	100nF~220nF	—	D
	16V	—	100nF~390nF	220nF~470nF	220nF~470nF	—	D
0805	50V	10pF~4.7nF	220pF~100nF	220pF~100nF	220pF~100nF	—	Y
		1.0nF~5.6nF	100nF~820nF	100nF~820nF	100nF~680nF	—	H
	25V	1.0nF~10nF	—	—	—	—	Y
		—	220nF~820nF	220nF~820nF	220nF~680nF	—	H
	16V	—	1.0μF	1.0μF	1.0μF	—	H
1206	50V	—	100nF	—	100nF	—	Y
		—	100nF~1.0μF	—	100nF~1.0μF	—	L
	25V	—	—	—	—	—	—
	16V	—	1.0μF	—	1.0μF	—	O

Note: 1) E12 series for X7R, X5R and X7S groups, E6 series for Y5V group, E24 series for C0G group, integer nominal values such as 1.0, 2.0, 3.0pF, etc. are allowed for the specifications below 10pF.

2) For products of the same size, material and capacity, the rated voltage can be covered from high to low.

VIIYONG GUANGDONG VIIYONG ELECTRONIC TECHNOLOGY CO., LTD.		Page number	4 / 14
File name	Multi-layer Ceramic Chip Capacitor	File type	Product Specification
Issued No.	SGVX-CCF202011	Confidentiality level	External public documents
		Date	2020-11-03

Type of Packing:

Reel Packaging (standard carrier tape disc packaging), every disc smallest package are shown in Table 4.

Table 4 Packing type

Chip Size	0402		0603	0805		1206	
Thickness code	B/N	B/N	D	H	Y	L/O	Y
Disc size	7"	13"	7"	7"	7"	7"	7"
Carrier Tape type	Paper	Paper	Paper	Plastic	Paper	Plastic	Paper
QTY (Kpcs)	10	50	4	2	4	2	4

First packaging: Each multi-disc material is packed into a box.

The second packaging: the first packaged packaging box is loaded into the paper packaging box, and the remaining space in the box is filled with light auxiliary materials. The above packaging forms can also be packaged according to user needs.

4. Specifications and Test Methods:

4.1 Visual Inspection:

4.1.1 Requirement: no obvious defects on ceramic body and termination.

4.1.2 Test Method: Microscope 10×

4.2 Size:

4.2.1 Requirement: Configuration and dimension of MLCC are shown in Figure 1 and Table 1.

4.2.2 Test Method: Measuring by gages which precision is not less than 0.01 mm .

4.3 Operating Environment:

C0G/C0H(NP0), X7R	Temperature: -55℃ ~+125℃;Relative humidity: ≤95%(25℃)	Atmosphere: 86kPa ~106KPa
X5R	Temperature: -55℃ ~+85℃;Relative humidity: ≤95%(25℃)	Atmosphere: 86kPa ~106KPa
Y5V	Temperature: -30℃ ~+85℃;Relative humidity: ≤95%(25℃)	Atmosphere: 86kPa ~106KPa
X7S	Temperature: -30℃ ~+125℃;Relative humidity: ≤95%(25℃)	Atmosphere: 86kPa ~106KPa

VIIYONG GUANGDONG VIIYONG ELECTRONIC TECHNOLOGY CO., LTD.		Page number	5 / 14
File name	Multi-layer Ceramic Chip Capacitor	File type	Product Specification
Issued No.	SGVX-CCF202011	Confidentiality level	External public documents
		Date	2020-11-03

4.4 Electrical Parameters and Test Methods:

Table 5 Specifications and Test Methods of MLCC Electrical Parameter

No.	Item	Specification	Test Method										
1	Capacitance (C)	Within the specified tolerance	Temperature: 18~28℃; Humidity: ≤RH 80%; Test frequency: COG/COH(NP0): C≤1000pF, f=1MHz±10%; C>1000pF, f=1KHz±10% X7R、X5R、Y5V、X7S: C≤100pF, f=1MHz±10%; C>100pF, f=1KHz±10% Test Voltage: C≤100pF 1.0±0.2Vrms; 100pF<C≤1μF: 1.0±0.2Vrms										
2	Tangent of Loss Angle/ (tgδ)	COG/COH(NP0): C≥30pF, tgδ≤10×10 ⁻⁴ ; C<30pF, tgδ≤1.0×(90/C+7)×10 ⁻⁴											
		<table border="0"> <tr> <td>X7R:</td> <td>X5R:</td> </tr> <tr> <td>U_R=50V tgδ≤350×10⁻⁴</td> <td>U_R=50V/25V tgδ≤750×10⁻⁴</td> </tr> <tr> <td>U_R=25V tgδ≤480×10⁻⁴</td> <td>U_R=16V tgδ≤800×10⁻⁴</td> </tr> <tr> <td>U_R≤16V tgδ≤500×10⁻⁴</td> <td>U_R=10V tgδ≤900×10⁻⁴</td> </tr> <tr> <td></td> <td>U_R=6.3V tgδ≤1000×10⁻⁴</td> </tr> </table>		X7R:	X5R:	U _R =50V tgδ≤350×10 ⁻⁴	U _R =50V/25V tgδ≤750×10 ⁻⁴	U _R =25V tgδ≤480×10 ⁻⁴	U _R =16V tgδ≤800×10 ⁻⁴	U _R ≤16V tgδ≤500×10 ⁻⁴	U _R =10V tgδ≤900×10 ⁻⁴		U _R =6.3V tgδ≤1000×10 ⁻⁴
		X7R:		X5R:									
U _R =50V tgδ≤350×10 ⁻⁴	U _R =50V/25V tgδ≤750×10 ⁻⁴												
U _R =25V tgδ≤480×10 ⁻⁴	U _R =16V tgδ≤800×10 ⁻⁴												
U _R ≤16V tgδ≤500×10 ⁻⁴	U _R =10V tgδ≤900×10 ⁻⁴												
	U _R =6.3V tgδ≤1000×10 ⁻⁴												
Y5V: U _R ≥25V tgδ≤950×10 ⁻⁴ U _R =16V tgδ≤1300×10 ⁻⁴ U _R ≤10V tgδ≤1600×10 ⁻⁴													
	X7S: U _R ≥25V tgδ≤1000×10 ⁻⁴ ; U _R =16V tgδ≤1250×10 ⁻⁴ ; U _R =10V tgδ≤1250×10 ⁻⁴ ; U _R ≤6.3V tgδ≤1500×10 ⁻⁴												
3	Insulation Resistances/ (Ri)	<table border="0"> <tr> <td colspan="2">COG/COH(NP0): C≤10nF, Ri≥10000MΩ C>10nF, Ri×C≥500s</td> </tr> <tr> <td>X7R、X5R、X7S: C≤25nF, Ri≥4000MΩ C>25nF, Ri×C≥100s</td> <td>Y5V: C≤25nF, Ri≥4000MΩ C>25nF, Ri×C≥100s</td> </tr> </table>	COG/COH(NP0): C≤10nF, Ri≥10000MΩ C>10nF, Ri×C≥500s		X7R、X5R、X7S: C≤25nF, Ri≥4000MΩ C>25nF, Ri×C≥100s	Y5V: C≤25nF, Ri≥4000MΩ C>25nF, Ri×C≥100s	Temperature: 18~28℃; Humidity: ≤RH 80%; Apply rated voltage within 60 ± 5S						
COG/COH(NP0): C≤10nF, Ri≥10000MΩ C>10nF, Ri×C≥500s													
X7R、X5R、X7S: C≤25nF, Ri≥4000MΩ C>25nF, Ri×C≥100s	Y5V: C≤25nF, Ri≥4000MΩ C>25nF, Ri×C≥100s												
4	Withstanding voltage (WV)	No breakdown or flashover during test	COG/COH(NP0): 3×U _R X7R、X5R、Y5V、X7S : 2.5×U _R t=1minute Charge/discharge current not exceeds 50mA.										

Note: Capacitance test instructions of Class 2 ceramic capacitors

When the capacitor initial capacitance is lower than its tolerance value, the test sample need to be heated for 60 ± 5 minutes at 150 °C ± 10 °C. Recover it, let sit at room temperature for 24±2 hrs, and then test the capacitance.

File name	Multi-layer Ceramic Chip Capacitor		File type	Product Specification	
Issued No.	SGVX-CCF202011	Confidentiality level	External public documents	Date	2020-11-03

4.5 Environment Test Specifications and Methods:

Without specific note, the “test method” in Table 6 is based on GB/T 21041/21042 IDT IEC60384-21/22

Table 6 Environment Test Specifications and Methods

No.	Item	Specification	Test Method
1	Temperature Coefficient of Capacitance (α_c) or Temperature Characteristics	<p>NP0(C0G/C0H): $\alpha_c \leq \pm 30 \text{ppm}/^\circ\text{C}$ (125°C); $-72 \leq \alpha_c \leq +30 \text{ppm}/^\circ\text{C}$ (-55°C);</p> <p>X7R,X5R: $\Delta C/C \leq \pm 15\%$</p> <p>X7S: $\Delta C/C \leq \pm 22\%$</p> <p>Y5V: $-82\% \leq \Delta C/C \leq +22\%$</p>	<p>Preliminary Drying for 16~24hrs C0G/C0H(NP0),Special preconditioning for 1hr at 150°C followed by 24hrs (X7R、X5R、Y5V) ,The ranges of capacitance change compared with the temperature ranges ($\theta_1, 25^\circ\text{C}, \theta_2$) shall be within the specified ranges.</p> <p>X5R: $\theta_1=-55^\circ\text{C}, \theta_2=85^\circ\text{C}$ X7R、X7S: $\theta_1=-55^\circ\text{C}, \theta_2=125^\circ\text{C}$ Y5V: $\theta_1=-30^\circ\text{C}, \theta_2=85^\circ\text{C}$</p> <p>Test voltage: 0402 X7R $27\text{nF} \leq C \leq 100\text{nF}$: $0.5 \pm 0.1 \text{Vrms}$ X7S: $0.5 \pm 0.2 \text{Vrms}$ others: $1.0 \pm 0.2 \text{Vrms}$</p>
2	Resistance to Soldering Heat	<p>Visual: No visible damage and terminations uncovered shall be less than 25%.</p> <p>Capacitance Change: NP0(C0G/C0H): $\Delta C/C \leq \pm 2.5\%$ or $\pm 0.25\text{pF}$, whichever is larger; X7R, X5R: $\Delta C/C \leq \pm 7.5\%$; X7S: $\Delta C/C \leq \pm 15\%$ Y5V: $\Delta C/C \leq \pm 20\%$</p> <p>$\text{tg}\delta$ and R_i: meet the initial specification in Table 5.</p>	<p>Special preconditioning for 1hr at 150°C followed by 24 ± 1hrs;Preheat the capacitor at 110 to 150°C for 30-60s. Immerse the capacitor in an eutectic solder solution at $260 \pm 5^\circ\text{C}$ for 10 ± 1 seconds. The depth of immersion is 10mm.Recover it, let sit at room temperature for 6~24hrs [C0G/C0H(NP0)] or 24 ± 2hrs (X7R、X5R、Y5V、X7S) , then observe appearance and measure electrical characteristics.</p>
3	Solderability	<p>75% min. coverage of both terminal electrodes is soldered evenly and continuously.</p>	<p>Immerse the test capacitor into a methanol solution containing rosin for 3 to 5 seconds, preheat it at 80 to 180°C for 30s to 60s and immerse it into molten solder of $235 \pm 5^\circ\text{C}$ for 2 ± 0.2 seconds. The depth of immersion is 10mm.</p>

File name	Multi-layer Ceramic Chip Capacitor		File type	Product Specification	
Issued No.	SGVX-CCF202011	Confidentiality level	External public documents	Date	2020-11-03

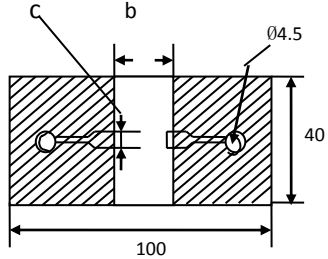
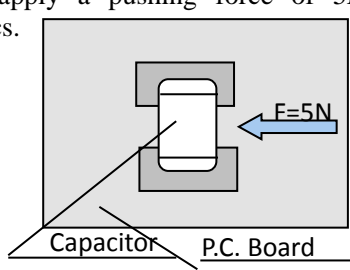
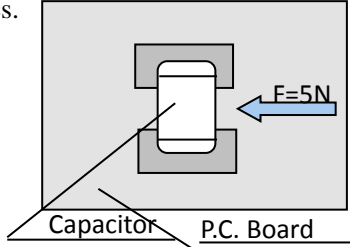
<p>4</p>	<p>Bond Strength of Termination</p>	<p>Visual: No visible damage. Capacitance Change: NP0(C0G/C0H): $\Delta C/C \leq \pm 5\%$ or $\pm 0.5\text{pF}$, whichever is larger; X7R, X5R X7S: $\Delta C/C \leq \pm 12.5\%$; Y5V: $\Delta C/C \leq \pm 30\%$</p>	<p>Solder the capacitor to the test jig (glass epoxy boards) shown in Fig. a. Apply a force in the direction shown in Fig. b. Bending 2mm at a speed of 1mm/sec and hold for 5 ± 1secs, then measure the capacitance.</p>  <p>Fig. a</p>  <p>Fig. b</p> <p>Capacitance</p> <p>(Unit: mm)</p>
<p>5</p>	<p>Adhesion</p>	<p>Visual: No visible damage.</p>	<p>When Soldering the capacitor on a P. C. board, apply a pushing force of 5N for 10 ± 1secs.</p>  <p>Capacitor P.C. Board</p>

File name	Multi-layer Ceramic Chip Capacitor		File type	Product Specification	
Issued No.	SGVX-CCF202011	Confidentiality level	External public documents	Date	2020-11-03

6	Vibration	Visual: No visible damage.	<p>Sample shall be mounted on a suitable substrate. Amplitude: 1.5mm Frequencies: 10 Hz~55 Hz and Harmonic vibration of uniform changes, 1 minutes sweep cycle. Repeat this for 2hrs each in 3 perpendicular directions X, Y, Z, total 6hrs. (Related STD: IEC 68-2-6 test Fc)</p>															
		<p>Capacitance Change: NP0(C0G/C0H): $\Delta C/C \leq \pm 2.5\%$ or $\pm 0.25\text{pF}$, whichever is larger; X7R, X5R: $\Delta C/C \leq \pm 7.5\%$; X7S: $\Delta C/C \leq \pm 15\%$; Y5V: $\Delta C/C \leq \pm 20\%$</p>																
		tgδ and Ri: meet the initial specification in Table 5.																
7	Rapid change of temperature	Visual: No visible damage.	<p>Special preconditioning for 1hr at 150°C followed by 24hrs. Fix the capacitor to the supporting jig. Expose the capacitors in the condition step 1 through 4 and perform 5 cycles.</p> <table border="1"> <thead> <tr> <th>Step</th> <th>temperature (°C)</th> <th>time</th> </tr> </thead> <tbody> <tr> <td>1</td> <td>θ_A</td> <td>30 min</td> </tr> <tr> <td>2</td> <td>25</td> <td>2~5 min</td> </tr> <tr> <td>3</td> <td>θ_B</td> <td>30 min</td> </tr> <tr> <td>4</td> <td>25</td> <td>2~5 min</td> </tr> </tbody> </table> <p>NP0(C0G/C0H), X7R, X7S: $\theta_A = -55^\circ\text{C}, \theta_B = 125^\circ\text{C}$; X5R: $\theta_A = -55^\circ\text{C}, \theta_B = 85^\circ\text{C}$ Y5V: $\theta_A = -30^\circ\text{C}, \theta_B = 85^\circ\text{C}$ Recover it, let sit at room temperature for 6~24hrs [C0G/C0H(NP0)] or 24±2hrs (X7R, X5R, Y5V, X7S), then observe appearance and measure electrical characteristics.</p>	Step	temperature (°C)	time	1	θ_A	30 min	2	25	2~5 min	3	θ_B	30 min	4	25	2~5 min
		Step		temperature (°C)	time													
		1		θ_A	30 min													
2	25	2~5 min																
3	θ_B	30 min																
4	25	2~5 min																
<p>Capacitance Change: NP0(C0G/C0H): $\Delta C/C \leq \pm 2.5\%$ or $\pm 0.25\text{pF}$, whichever is larger; X7R, X5R: $\Delta C/C \leq \pm 15\%$; X7S: $\Delta C/C \leq \pm 20\%$; Y5V: $\Delta C/C \leq \pm 20\%$</p>																		
tgδ and Ri: meet the initial specification in Table 5.																		

File name	Multi-layer Ceramic Chip Capacitor		File type	Product Specification	
Issued No.	SGVX-CCF202011	Confidentiality level	External public documents	Date	2020-11-03

8	Damp Heat (Steady State)	Visual: No visible damage.	Special preconditioning for 1hr at 150 °C followed by 24hr Test Temperature: 60 °C ±2 °C Humidity: RH 90~95% Duration:500hrs Recover it, let sit at room temperature for 6~24hrs [C0G/C0H(NP0)] or 24±2hrs(X7R,X5R,Y5V,X7S), then observe appearance and measure electrical characteristics.
		Capacitance Change: NP0(C0G/C0H): $\Delta C/C \leq \pm 5\%$ or $\pm 0.5\text{pF}$, whichever is larger; X7R, X5R: $\Delta C/C \leq \pm 12.5\%$; X7S: $\Delta C/C \leq \pm 30\%$; Y5V: $\Delta C/C \leq \pm 30\%$	
		tgδ: NP0(C0G/C0H): $\text{tg}\delta \leq 20 \times 10^{-4}$ ($C \geq 30\text{pF}$) or $\text{tg}\delta \leq 2 \times (90/C + 7) \times 10^{-4}$ ($C < 30\text{pF}$); X7R: $\text{tg}\delta \leq 700 \times 10^{-4}$; X7S: $\text{tg}\delta \leq 2 \times$ the initial specification in Table5; X5R: $\text{tg}\delta \leq 1200 \times 10^{-4}$ Y5V: $U_R \geq 25\text{V}$ $\text{tg}\delta \leq 950 \times 10^{-4}$ $U_R = 16\text{V}$ $\text{tg}\delta \leq 1300 \times 10^{-4}$ $U_R < 16\text{V}$ $\text{tg}\delta \leq 1600 \times 10^{-4}$.	
		Ri: NP0(C0G/C0H): $R_i \geq 2500\text{M}\Omega$ or $R_i \times C \geq 50\text{s}$, which is smaller; X7R,X5R,Y5V,X7S: $R_i \geq 1000\text{M}\Omega$ or $R_i \times C \geq 50\text{s}$ ($U_R \geq 25\text{V}$), which is smaller; $R_i \geq 1000\text{M}\Omega$ or $R_i \times C \geq 10\text{s}$ ($U_R \leq 16\text{V}$), which is smaller.	

File name	Multi-layer Ceramic Chip Capacitor		File type	Product Specification	
Issued No.	SGVX-CCF202011	Confidentiality level	External public documents	Date	2020-11-03

9	Damp heat with load	Visual: No visible damage.	<p>Special preconditioning for 1hr at 150°C. Remove and set for 24hours at room temperature. Perform initial measurement. Test Temperature: 60±2°C; Humidity: RH 90~95%; Test Voltage: 1.0×U_R; Duration: 500hrs; Charge/discharge current not exceeds 50mA. Recover it, let sit at room temperature for 6~24hrs [COG/COH(NP0)] or 24±2hrs (X7R,X5R,Y5V,X7S), then observe appearance and measure electrical characteristics. (X5R≥100nF Special preconditioning for 1hr at 150°C followed by 24±4hrs).</p>
		<p>Capacitance Change: NP0(C0G/C0H): ΔC/C≤±7.5% or ±0.75pF, which is larger; X7R: ΔC/C≤±12.5%; X7S: ΔC/C≤±30% X5R: ΔC/C≤±15%; Y5V: ΔC/C≤±30%.</p>	
		<p>Tgδ: NP0(C0G/C0H): tgδ≤50×10⁻⁴ (C≥30pF) or tgδ≤5×(90/C+7)×10⁻⁴ (C<30pF); X7R:tgδ≤700×10⁻⁴; X7S:tgδ≤2×the initial specification in Table5; X5R: tgδ≤1200×10⁻⁴; Y5V:U_R≥25V tgδ≤950×10⁻⁴; U_R =16V tgδ≤1300×10⁻⁴; U_R <16V tgδ≤1600×10⁻⁴.</p>	
		Ri: Ri≥500MΩ or Ri×C≥25s, which is smaller	

File name	Multi-layer Ceramic Chip Capacitor		File type	Product Specification	
Issued No.	SGVX-CCF202011	Confidentiality level	External public documents	Date	2020-11-03

10	Endurance	Visual: No visible damage.	Special preconditioning for 1hr at 150°C followed by 24hrs Test Temperature: NP0(C0G/C0H)/X7R/X7S: 125°C; X5R/ Y5V: 85°C; Duration: 1000hrs; Test Voltage: 1.5×U _R Recover it, let sit at room temperature for 6~24hrs [C0G/C0H(NP0)] or 24±2hrs (X7R,X5R,Y5V,X7S) , then observe appearance and measure electrical characteristics. (X5R≥100nF Special preconditioning for 1hr at 150°C followed by 24±4hrs)。
		Capacitance Change: NP0(C0G/C0H): ΔC/C≤±3% or ±0.3pF, which is larger; X7R, X5R: ΔC/C≤±15%; X7S: ΔC/C≤±30%; Y5V: ΔC/C≤±30%.	
		Tgδ: NP0(C0G/C0H): tgδ≤20×10 ⁻⁴ (C≥30pF) or tgδ≤2×(90/C+7)×10 ⁻⁴ (C<30pF); X7R:tgδ≤700×10 ⁻⁴ ; X7S:tgδ≤2×the initial specification in Table5; X5R: tgδ≤1200×10 ⁻⁴ ; Y5V:U _R ≥25V tgδ≤950×10 ⁻⁴ U _R =16V tgδ≤1300×10 ⁻⁴ U _R <16V tgδ≤1600×10 ⁻⁴ .	
		Ri: NP0(C0G/C0H): Ri≥1000MΩ or Ri×C≥50s, which is smaller; X7R,X5R,Y5V,X7S: Ri≥1000MΩ or Ri×C≥50s (U _R ≥25V), which is smaller; Ri≥1000MΩ or Ri×C≥10s (U _R ≤16V), which is smaller.	

File name	Multi-layer Ceramic Chip Capacitor		File type	Product Specification	
Issued No.	SGVX-CCF202011	Confidentiality level	External public documents	Date	2020-11-03

5. Packaging, Shipment and storage:

5.1 Packing:

5.1.1 Packing type:

Reel Packaging (standard carrier tape disc packaging), single disc smallest package are shown in Table 4.

5.1.2 Carrier Tape size:

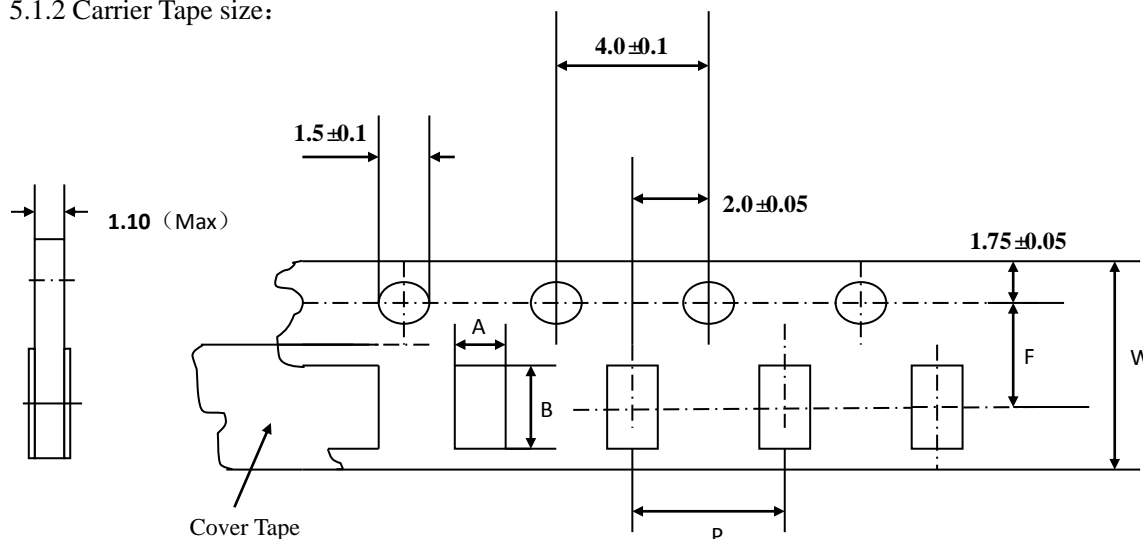

Figure 2 Carrier

Table 7 Carrier size

Mark	Size of product			
	0402	0603	0805	1206
	Size (Unit: mm)			
A (Width of the square hole)	0.70±0.10	1.00±0.20	1.60±0.20	2.00±0.20
B (Length of the square hole)	1.20±0.10	1.80±0.20	2.40±0.20	3.60±0.20
F (Center distance between positioning hole and square hole)	3.50±0.05	3.50±0.05	3.50±0.05	3.50±0.05
P (Square hole spacing)	2.00±0.10	4.00±0.10	4.00±0.10	4.00±0.10
W (Width of carrier)	8.00±0.20	8.00±0.20	8.00±0.20	8.00±0.20

File name	Multi-layer Ceramic Chip Capacitor		File type	Product Specification	
Issued No.	SGVX-CCF202011	Confidentiality level	External public documents	Date	2020-11-03

5.1.3 Disc size:

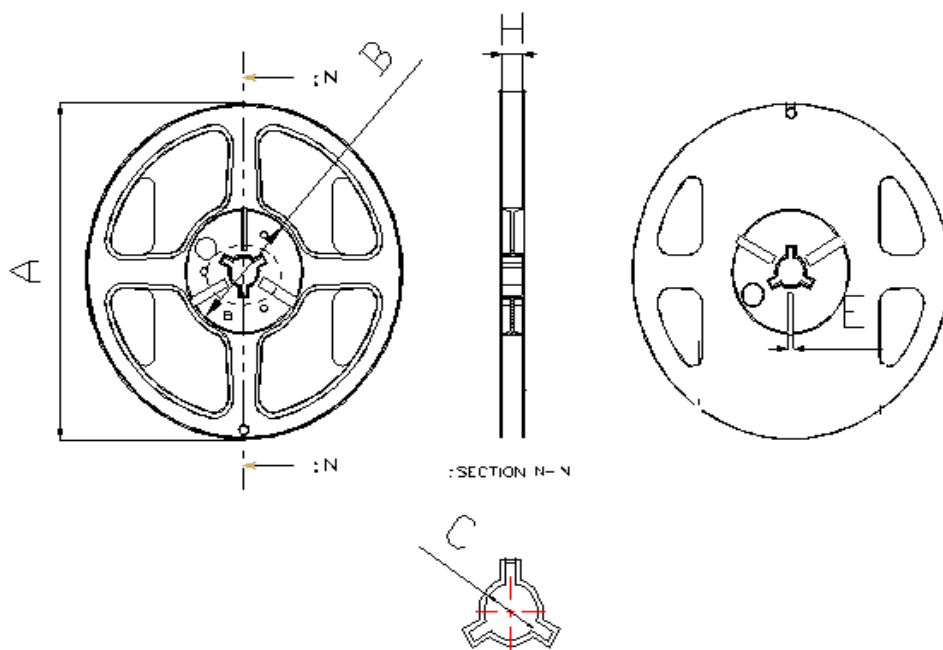
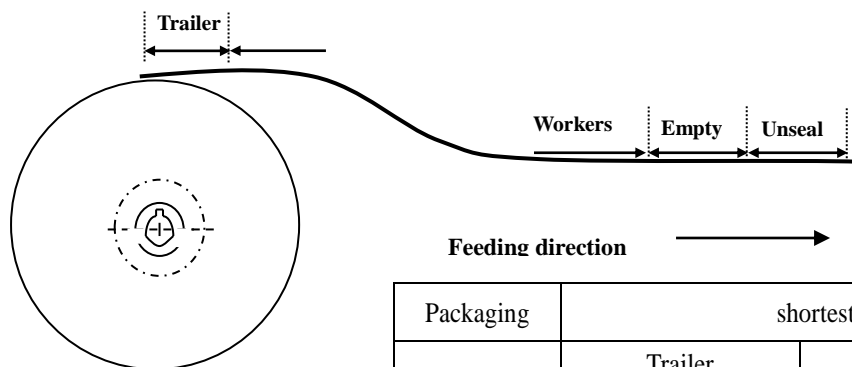

Figure 3 Disc

Table 8 Disc size

Disc Size	A/mm	B/mm	C/mm	E/mm	H/mm
7"	$\Phi 178 \pm 2.0$	$\Phi 60 \pm 2.0$	$\Phi 13 \pm 1.0$	4 ± 1.0	9.5 ± 1.0
13"	$\Phi 330 \pm 2.0$	$\Phi 100 \pm 2.0$	$\Phi 13 \pm 1.0$	3 ± 1.0	10 ± 1.0

5.1.4 Carrier specifications:



Packaging	shortest length of the reserved space		
Carrier	Trailer	Empty	Unseal
	60 mm	200mm	160 mm

VIIYONG GUANGDONG VIIYONG ELECTRONIC TECHNOLOGY CO., LTD.		Page number	14 / 14
File name	Multi-layer Ceramic Chip Capacitor	File type	Product Specification
Issued No.	SGVX-CCF202011	Confidentiality level	External public documents
		Date	2020-11-03

5.1.5 Performance of Carrier Taping:

5.1.5.1 Strength of Carrier Tape and Top Cover Tape:

a. Carrier Tape

When a tensile force 1.02kgf is applied in the direction to unreel the tape, the tape shall withstand this force.

b. Top cover Tape

When a tensile force 1.02kgf is applied to the tape, the tape shall withstand this force.

5.1.5.2 Peeling Strength of Top Cover Tape:

Unless otherwise specified, the peeling strength of top cover tape shall be within 10.2 to 71.4 gf when the top cover tape is pulled at a speed of 300mm/min with the angle of 0 to 15 °(see the following figure).

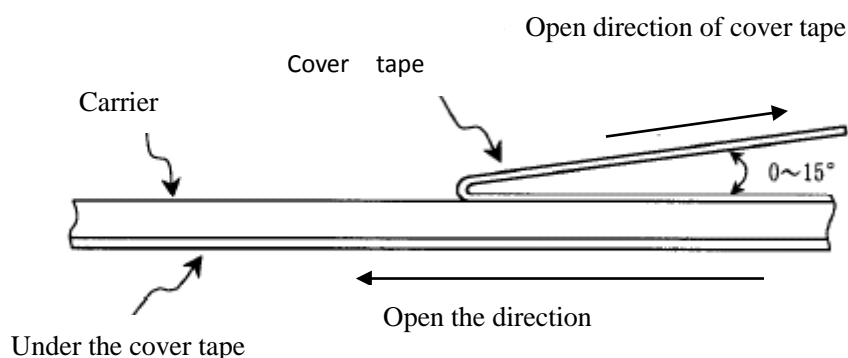

5.2 Shipment:

It must not be got rain, snow, and must avoid erosion of acid and alkali during the course of shipment.

5.3 Storage:

Period of Store:

12 months, otherwise, its solderability must be inspected again.

Condition of Store:

Temperature: Below 35°C

Humidity: Below RH70%.

X-ON Electronics

Largest Supplier of Electrical and Electronic Components

Click to view similar products for [Multilayer Ceramic Capacitors MLCC - SMD/SMT](#) category:

Click to view products by [VIHYONG](#) manufacturer:

Other Similar products are found below :

[M39014/02-1218V](#) [M39014/02-1225V](#) [M39014/22-0631](#) [D55342E07B523DR-T/R](#) [NCA1206X7R104K16TRPF](#) [NIN-FB391JTRF](#) [NIN-FC2R7JTRF](#) [NMC0402NPO220J50TRPF](#) [NMC0402X5R105K6.3TRPF](#) [NMC0402X5R224K6.3TRPF](#) [NMC0402X7R103J25TRPF](#) [NMC0402X7R153K16TRPF](#) [NMC0603NPO101F50TRPF](#) [NMC0603NPO1R8C50TRPF](#) [NMC0603NPO201J50TRPF](#) [NMC0603X5R475M6.3TRPF](#) [NMC0805NPO270J50TRPF](#) [NMC0805NPO681F50TRPF](#) [NMC0805NPO820J50TRPF](#) [NMC0805X7R224K16TRPLPF](#) [NMC0805X7R224K25TRPF](#) [NMC1206X7R102K50TRPF](#) [NMC1206X7R475K10TRPLPF](#) [NMC-Q0402NPO8R2D200TRPF](#) [C1206C101J1GAC](#) [C1608C0G2A221J](#) [C1608X7R1E334K](#) [C2012C0G2A472J](#) [2220J2K00562KXT](#) [1812J2K00332KXT](#) [CDR04BX104AKSR](#) [CDR31BX103AKWR](#) [CDR33BX104AKUR](#) [CDR33BX683AKUS](#) [CGA2B2C0G1H010C](#) [CGA2B2C0G1H040C](#) [CGA2B2C0G1H050C](#) [CGA2B2C0G1H060D](#) [CGA2B2C0G1H070D](#) [CGA2B2C0G1H120J](#) [CGA2B2C0G1H151J](#) [CGA2B2C0G1H1R5C](#) [CGA2B2C0G1H2R2C](#) [CGA2B2C0G1H390J](#) [CGA2B2C0G1H391J](#) [CGA2B2C0G1H3R3C](#) [CGA2B2C0G1H680J](#) [CGA2B2C0G1H6R8D](#) [CGA2B2C0G1H820J](#) [CGA2B2X8R1H152K](#)