

Data Sheet

Customer:

Product: Automotive Grade Chip Resistor – CR..A Series

Size: 0201/0402/0603/0805/1206/1210/2010/2512

Issued Date: 21-Oct-19

Edition: REV.B1



VIKING TECH CORPORATION
光頡科技股份有限公司
No.70 Guangfu N. Rd., Hukou
Township, Hsinchu County 303,
Taiwan

TEL:886-3-5972931
FAX:886-3-5972935•886-3-5973494
E-mail:sales@viking.com.tw

VIKING TECH CORPORATION KAOHSIUNG BRANCH
光頡科技股份有限公司高雄分公司
No.248-3, Sin-Sheng Rd., Cian-Jhen Dist., Kaohsiung,
806, Taiwan

TEL:886-7-8217999
FAX:886-7-8228229
E-mail:sales@viking.com.tw

VIKING ELECTRONICS (WUXI) CO., LTD.
光頡電子(無錫)有限公司
No.22 Xixia Road, Machinery & Industry Park,
National Hi-Tech Industrial Development Zone
of Wuxi, Wuxi, Jiangsu Province, China
Zip Code:214028
TEL:86-510-85203339
FAX:86-510-85203667•86-510-85203977
E-mail:china@viking.com.tw

Produced by (QC)	Checked (QC)	Approved by (QC)	Prepared by (Sales)	Accepted by (Customer)
21-Oct-19	21-Oct-19	21-Oct-19	21-Oct-19	
Susan Huang	J.C. Liu	J.C. Liu		

Automotive Grade Chip Resistor-CR..A Series



Scope

- This specification applies to all sizes of rectangular-type fixed chip resistors with Ruthenium-base as material.

Features

- AEC-Q200 Compliance
- Highly reliable multilayer electrode construction
- Compatible with all soldering process
- 100% CCD inspection

Construction



Applications

- Automotive Industry
- Telecommunication Equipments
- Radio and Tape Recorders, TV Tuners
- Digital Cameras, Watches, Pocket Calculators
- Computers, Instruments
- Medical Equipment

① Alumina Substrate	④ Edge Electrode	⑦ Resistor Layer
② Bottom Electrode	⑤ Barrier Layer	⑧ Primary Overcoat
③ Top Electrode	⑥ External Electrode	⑨ Secondary Overcoat

Dimensions

Type	Size (Inch)	L (mm)	W (mm)	T (mm)	D1 (mm)	D2 (mm)	Weight (g) (1000pcs)
CR-01	0201	0.60±0.03	0.30±0.03	0.23±0.03	0.15±0.05	0.15±0.05	0.150
CR-02	0402	1.00±0.05	0.50±0.05	0.35±0.05	0.20±0.10	0.20±0.10	0.620
CR-03	0603	1.60±0.10	0.80±0.10	0.45±0.10	0.30±0.20	0.30±0.20	2.042
CR-05	0805	2.00±0.10	1.25±0.10	0.50±0.10	0.35±0.20	0.40±0.20	4.368
CR-06	1206	3.10±0.10	1.55±0.10	0.55±0.10	0.50±0.25	0.50±0.20	8.947
CR-10	1210	3.10±0.10	2.60±0.15	0.55±0.10	0.50±0.25	0.50±0.20	15.959
CR-0A	2010	5.00±0.10	2.50±0.15	0.55±0.10	0.60±0.25	0.50±0.20	24.241
CR-12	2512	6.35±0.10	3.10±0.15	0.55±0.10	0.60±0.25	0.50±0.20	39.448

Part Numbering

Part Number : CR-03FA7---10R

CR-	03	F	A	7	- - - 1 0 R
Product Type	Dimensions	Resistance Tolerance	Function Code	Packaging Code	Resistance
CR-	01: 0201 02: 0402 03: 0603 05: 0805 06: 1206 10: 1210 0A: 2010 12: 2512	D: ±0.5% F: ±1% J: ±5%	A: Automotive Grade C: High Power & Automotive Grade	4: 7" Reel 4Kpcs 6: 7" Reel 10Kpcs 7: 7" Reel 5Kpcs 9: 10" Reel 8Kpcs A: 10" Reel 10Kpcs B: 10" Reel 20Kpcs C: 13" Reel 40Kpcs D: 13" Reel 20Kpcs	--- 1R2: 1.2Ω --- 3K3: 3.3KΩ --- 10K: 10KΩ -- 100K: 100KΩ "-" to fill up 6 spaces

Recommend Land Pattern



Type	A (mm)	B (mm)	C (mm)
CR-01	0.30	0.25	0.30
CR-02	0.50	0.45	0.60
CR-03	0.90	0.60	0.90
CR-05	1.20	0.70	1.30
CR-06	2.00	0.90	1.60
CR-10	2.00	0.90	2.80
CR-0A	3.80	0.90	2.80
CR-12	4.90	1.60	3.50

Derating Curve

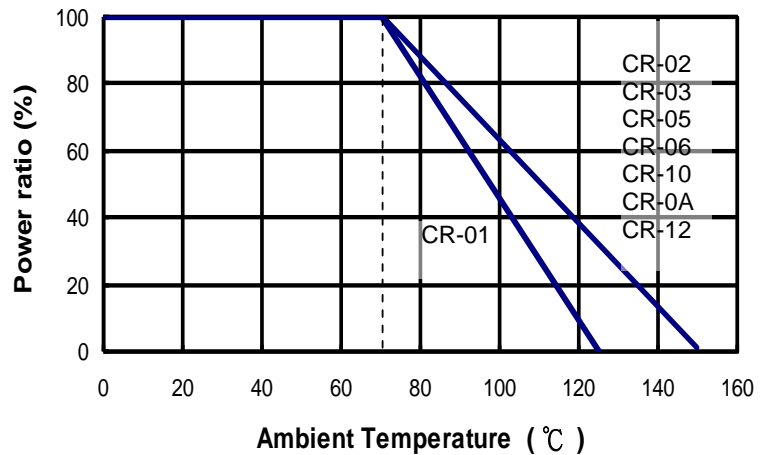

Soldering Condition



IR Reflow Soldering



Wave Soldering (Flow Soldering)

- (1) Time of IR reflow soldering at maximum temperature point 260°C : 10s
- (2) Time of wave soldering at maximum temperature point 260°C : 10s

(3) Time of soldering iron at maximum temperature point 410°C : 5s

Standard Electrical Specifications

Type	Item	Power Rating at 70°C Jumper Rated Current	Operating Temp. Range	Max. Operating Voltage	Max. Overload Voltage	Resistance Range		TCR (PPM/°C)
						±1%(E24、E96)	±5%(E24)	
CR-01 (0201)	1/20W	Jumper: 1A	-55 ~ +125°C	25V	50V	1Ω - 10MΩ		±200
	-					0Ω (<50mΩ)	-	
CR-02 (0402)	1/16W	Jumper: 1A	-55 ~ +155°C	50V	100V	1Ω - 9.76Ω 10Ω - 1MΩ 1.02MΩ - 10MΩ		±200 ±100 ±200
	-					0Ω (<50mΩ)	-	
CR-03 (0603)	1/10W	Jumper: 1A	-55 ~ +155°C	75V	150V	1Ω - 9.76Ω 10Ω - 1MΩ 1.02MΩ - 10MΩ		±200 ±100 ±200
	-					0Ω (<50mΩ)	-	
CR-05 (0805)	1/8W	Jumper: 2A	-55 ~ +155°C	150V	300V	1Ω - 9.76Ω 10Ω - 1MΩ 1.02MΩ - 10MΩ		±200 ±100 ±200
	-					0Ω (<50mΩ)	-	
CR-06 (1206)	1/4W	Jumper: 2A	-55 ~ +155°C	200V	400V	1Ω - 9.76Ω 10Ω - 1MΩ 1.02MΩ - 10MΩ		±200 ±100 ±200
	-					0Ω (<50mΩ)	-	
CR-10 (1210)	1/2W	Jumper: 2.5A	-55 ~ +155°C	200V	400V	1Ω - 9.76Ω 10Ω - 1MΩ 1.02MΩ - 10MΩ		±200 ±100 ±200
	-					0Ω (<50mΩ)	-	
CR-0A (2010)	3/4W	Jumper: 3.5A	-55 ~ +155°C	200V	400V	1Ω - 9.76Ω 10Ω - 1MΩ 1.02MΩ - 10MΩ		±200 ±100 ±200
	-					0Ω (<50mΩ)	-	
CR-12 (2512)	1W	Jumper: 4A	-55 ~ +155°C	250V	500V	1Ω - 9.76Ω 10Ω - 1MΩ 1.02MΩ - 10MΩ		±200 ±100 ±200
	-					0Ω (<50mΩ)	-	

High Precision Electrical Specifications

Type	Item	Power Rating at 70°C	Operating Temp. Range	Max. Operating Voltage	Max. Overload Voltage	Resistance Range (E24、E96)	TCR (PPM/°C)
						±0.5%	
CR-02 (0402)	1/16W	-55 ~ +155°C		50V	100V	10Ω - 1MΩ	±100
CR-03 (0603)	1/10W			75V	150V	10Ω - 1MΩ	±100
CR-05 (0805)	1/8W			150V	300V	10Ω - 1MΩ	±100
CR-06 (1206)	1/4W			200V	400V	10Ω - 1MΩ	±100
CR-10 (1210)	1/3W			200V	400V	10Ω - 1MΩ	±100
CR-0A (2010)	3/4W			200V	400V	10Ω - 1MΩ	±100
CR-12 (2512)	1W			250V	500V	10Ω - 1MΩ	±100

High Power Rating Electrical Specifications

Type \ Item	Power Rating at 70°C	Operating Temp. Range	Max. Operating Voltage	Max. Overload Voltage	Resistance Range		TCR (PPM/°C)
					±1% (E24 · E96)	±5% (E24)	
CR-02 (0402)	1/8W	-55 ~ +155°C	50V	100V	1Ω - 9.76Ω 10Ω - 1MΩ		±200 ±100
CR-03 (0603)	1/4W		75V	150V			
CR-05 (0805)	1/3W		150V	300V			
CR-06 (1206)	1/2W		200V	400V			
CR-0A (2010)	1W		200V	400V			
CR-12 (2512)	2W		250V	500V			

Operating Voltage= $\sqrt{P \cdot R}$ or Max. Operating Voltage listed above, whichever is lower.

Overload Voltage= $2.5 \cdot \sqrt{P \cdot R}$ or Max. Overload Voltage listed above, whichever is lower.

The power rating depends on the maximum temperature of the resistive element. Due to the power dissipation of the resistor, the temperature of the resistive element will rise depending on the condition of heat dissipation from PCB. The maximum power rating in application only applies if the temperature of the resistive element is not exceed 155 °C.

■ Viking is capable of manufacturing the optional spec based on customer's requirement.

Environmental Characteristics

Item	Requirement			Test Method
	±1% and Below	±5%	Jumper	
Temperature Coefficient of Resistance (T.C.R.)	As Spec.			JIS-C-5201-1 4.8 IEC-60115-1 4.8 At 25°C/-55°C and 25°C/+125°C, 25°C is the reference temperature
Short Time Overload	±(1.0%+0.05Ω)	±(2.0%+0.05Ω)	<50mΩ	JIS-C-5201-1 4.13 IEC-60115-1 4.13 RCWV*2.5 or Max. Overload Voltage whichever is lower for 5 seconds
Insulation Resistance	≥10G			JIS-C-5201-1 4.6 IEC-60115-1 4.6 Max. Overload Voltage for 1 minute
Operational Life	±(1.0%+0.10Ω)	±(2.0%+0.10Ω)	<100mΩ	MIL-STD-202 Method 108 Condition D Steady State TA=125°C at derated power. Measurement at 24±4 hours after test conclusion.
Biased Humidity	±(1.0%+0.10Ω)	±(2.0%+0.10Ω)	<100mΩ	MIL-STD-202 Method 103 1000 hrs 85°C/85%RH 10% of operating power
High Temperature Exposure	±(1.0%+0.05Ω)	±(1.5%+0.10Ω)	<50mΩ	MIL-STD-202 Method 108 at +125/+155°C for 1000 hrs
Board Flex	±(1.0%+0.05Ω)	±(1.0%+0.05Ω)	<50mΩ	AEC-Q200-005 Bending once for 60 seconds 2010, 2512 sizes: 2mm Other sizes: 3mm

Automotive Grade Chip Resistor

Item	Requirement			Test Method
	±1% and Below	±5%	Jumper	
Solderability	95% min. coverage			JIS-C-5201-1 4.17 IEC-60115-1 4.17 J-STD-002 245±5°C for 3 seconds
Resistance to Soldering Heat	±(0.5%+0.05Ω)	±(1.0%+0.05Ω)	<50mΩ	MIL-STD-202 Method 210 260±5°C for 10 seconds
Voltage Proof	No breakdown or flashover			JIS-C-5201-1 4.7 IEC-60115-1 4.7 1.42 times Max. Operating Voltage for 1 minute
Leaching	Individual leaching area ≤5% Total leaching area ≤ 10%			JIS-C-5201-1 4.18 IEC-60068-2-58 8.2.1 260±5°C for 30 seconds
Temperature Cycling	±(0.5%+0.05Ω)	±(1.5%+0.05Ω)	<50mΩ	JESD22 Method JA-104 -55°C to +125°C, 1000 cycles
Mechanical Shock	±(0.25%+0.05Ω)	±(1.0%+0.05Ω)	<50mΩ	MIL-STD-202 Method 213 Wave Form: Tolerance for half sine shock pulse. Peak value is 100g's. Normal duration (D) is 6.
Vibration	±(0.5%+0.05Ω)	±(1.0%+0.05Ω)	<50mΩ	MIL-STD-202 Method 204 5 g's for 20 min., 12 cycles each of 3 orientations, 10-2000 Hz
ESD	±(3%+0.05Ω)			AEC-Q200-002 Human body model 0201: 0.5KV 0402/0603: 1KV 0805 and above: 2KV
Resistance to Solvents	No visible damage on appearance and marking.			MIL-STD-202 Method 215 Add Aqueous wash chemical - OKEM Clean or equivalent. Do not use banned solvents.
Terminal Strength	No broken			AEC-Q200-006 Force of 1.8kg for 60 seconds.
Flammability	No ignition of the tissue paper or scorching or the pinewood board			UL-94 V-0 or V-1 are acceptable. Electrical test not required.
Sulfur Test	△R±1%		<50mΩ	EIA-977 (Condition A) 60±2°C, no power rating for 480 hrs.

RCWV(Rated Continuous Working Voltage)= $\sqrt{P \cdot R}$ or Max. Operating Voltage whichever is lower.

■ **Storage Temperature: 15~28°C; Humidity < 80%RH**

■ Packaging

Reel Specifications & Packaging Quantity



Type	Packaging Quantity	Tape Width	Reel Diameter	ΦA (mm)	ΦB (mm)	ΦC (mm)	W (mm)	T (mm)	
CR-01 CR-02	Paper	10K	8mm	7 inch	178.5±1.5	60 ^{+1/-0}	13.0±0.2	9.0±0.5	12.5±0.5
		20K	8mm	10 inch	254±1.0	100±0.5	13.0±0.2	9.5±0.5	13.5±0.5
		40K	8mm	13 inch	330±1.0	100±0.5	13.0±0.2	9.5±0.5	13.5±0.5
CR-03 CR-05 CR-06 CR-10	Paper	5K	8mm	7 inch	178.5±1.5	60 ^{+1/-0}	13.0±0.2	9.0±0.5	12.5±0.5
		10K	8mm	10 inch	254±1.0	100±0.5	13.0±0.2	9.5±0.5	13.5±0.5
		20K	8mm	13 inch	330±1.0	100±0.5	13.0±0.2	9.5±0.5	13.5±0.5
CR-0A CR-12	Embossed	4K	12mm	7 inch	178.5±1.5	60 ^{+1/-0}	13.0±0.5	13.0±0.5	15.5±0.5
		8K	12mm	10 inch	250±1.0	62±0.5	13.0±0.5	12.5±0.5	16.5±0.5

Pap

Reel Tape Specifications

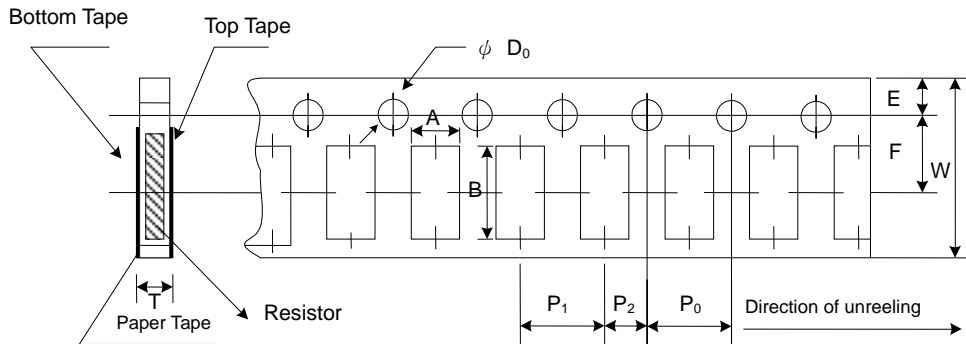

Type	A (mm)	B (mm)	W (mm)	E (mm)	F (mm)	P ₀ (mm)	P ₁ (mm)	P ₂ (mm)	ΦD ₀ (mm)	T (mm)
CR-01	0.38±0.05	0.68±0.05	8.0±0.20	1.75±0.10	3.50±0.05	4.00±0.10	2.00±0.05	2.00±0.05	1.50+0.1,-0	0.42±0.20
CR-02	0.65±0.10	1.15±0.10	8.0±0.20	1.75±0.10	3.50±0.05	4.00±0.10	2.00±0.05	2.00±0.05	1.50+0.1,-0	0.45±0.10
CR-03	1.10±0.10	1.90±0.10	8.0±0.20	1.75±0.10	3.50±0.05	4.00±0.10	4.00±0.05	2.00±0.05	1.50+0.1,-0	0.70±0.10
CR-05	1.60±0.10	2.40±0.20	8.0±0.20	1.75±0.10	3.50±0.05	4.00±0.10	4.00±0.05	2.00±0.05	1.50+0.1,-0	0.85±0.10
CR-06	1.90±0.10	3.50±0.20	8.0±0.20	1.75±0.10	3.50±0.05	4.00±0.10	4.00±0.05	2.00±0.05	1.50+0.1,-0	0.85±0.10
CR-10	2.90±0.10	3.50±0.20	8.0±0.20	1.75±0.10	3.50±0.05	4.00±0.10	4.00±0.05	2.00±0.05	1.50+0.1,-0	0.85±0.10

Embossed Plastic Tape Specifications

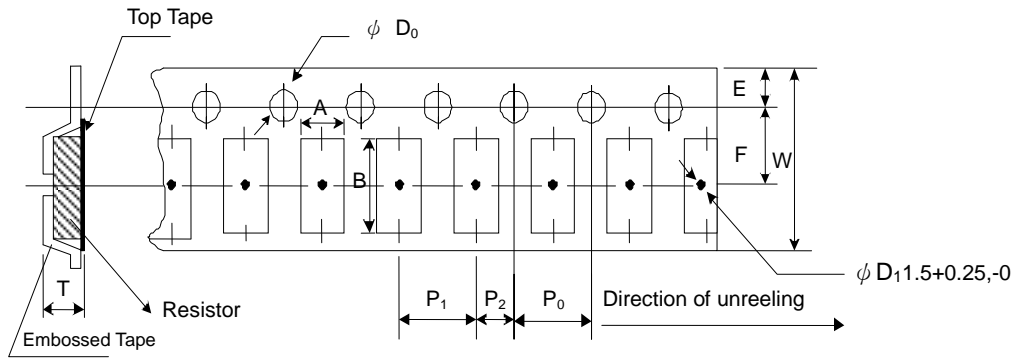

Type	A (mm)	B (mm)	W (mm)	E (mm)	F (mm)	P ₀ (mm)	P ₁ (mm)	P ₂ (mm)	ΦD ₀ (mm)	T (mm)
CR-0A	2.8±0.10	5.5±0.10	12.0±0.30	1.75±0.10	5.5±0.05	4.00±0.10	4.00±0.10	2.00±0.05	1.50+0.1, -0	1.2 ⁺⁰
CR-12	3.5±0.10	6.7±0.10	12.0±0.30	1.75±0.10	5.5±0.05	4.00±0.10	4.00±0.10	2.00±0.05	1.50+0.1, -0	1.2 ⁺⁰

■ Marking

No Marking for 0201/0402

Jumper for all: Letter "0"

1% for 0805/1206/1210/2010/2512: 4 digits marking

Example:

Resistance	100Ω	2.2KΩ	10KΩ	49.9KΩ	100KΩ
Marking	1000	2201	1002	4992	1003

5% for 0603/0805/1206/1210/2010/2512: 3 digits marking in E24

Example: 101=100Ω 102=1KΩ (1st and 2nd are E24 code and 3rd code is multiplier)

E24 code	10	11	12	13	15	16	18	20	22	24	27	30	33	36	39	43	47	51	56	62	68	75	82	91
----------	----	----	----	----	----	----	----	----	----	----	----	----	----	----	----	----	----	----	----	----	----	----	----	----

1% for 0603(E24): 3 digits marking in E24, When the E24 and E96 are the same resistance, this marking in E96

Example: 01A= 100Ω 05C=11KΩ 123=12KΩ 273=27KΩ

1% for 0603(E96): 3 digits marking in E96



3 digits marking for Example: 14C=13K7Ω 13C=13K3Ω
68B=4K99Ω 68X=49.9Ω

Marking Table

Code	E96	Code	E96	Code	E96	Code	E96				
01	100	25	178	49	316	73	562				
02	102	26	182	50	324	74	576				
03	105	27	187	51	332	75	590				
04	107	28	191	52	340	76	604				
05	110	29	196	53	348	77	619				
06	113	30	200	54	357	78	634				
07	115	31	205	55	365	79	649				
08	118	32	210	56	374	80	665				
09	121	33	215	57	383	81	681				
10	124	34	221	58	392	82	698				
11	127	35	226	59	402	83	715				
12	130	36	232	60	412	84	732				
13	133	37	237	61	422	85	750				
14	137	38	243	62	432	86	768				
15	140	39	249	63	442	87	787				
16	143	40	255	64	453	88	806				
17	147	41	261	65	464	89	825				
18	150	42	267	66	475	90	845				
19	154	43	274	67	487	91	866				
20	158	44	280	68	499	92	887				
21	162	45	287	69	511	93	909				
22	165	46	294	70	523	94	931				
23	169	47	301	71	536	95	953				
24	174	48	309	72	549	96	976				
Code	A	B	C	D	E	F	G	X	Y		
Multiplier	10 ⁰	10 ¹	10 ²	10 ³	10 ⁴	10 ⁵	10 ⁶	10 ⁻¹	10 ⁻²		

REVISION HISTORY

REVISION	DATE	CHANGE NOTIFICATION	DESCRIPTION
Version A5	Apr 30, 2015	-	- Environmental Characteristics updated
Version A6	Jun 18, 2015	-	- Increased 0603(E24) 1% marking description
Version A7	Jul 15, 2016	-	- Remove Material Description - Size CR-01 specifications added - Modify Storage Temperature - Increased 0.5% Resistance Range - Increased High Power Rating Electrical Specifications
Version A8	Jan 12, 2018	-	- Environmental Characteristics updated - Modify Electrical Specifications (0R) - Modify 2512 Land Pattern
Version A9	May 20, 2019	-	- Modify TCR Test description - Features added 100% CCD inspection - Added Sulfur Test
Version B	Jun 1, 2019	-	- Modify ESD Test description & Spec.
Version B1	Oct 21, 2019	-	- increase 2512 2W Specifications - increase Special standard packaging specifications (disc 10" & 13")

X-ON Electronics

Largest Supplier of Electrical and Electronic Components

Click to view similar products for [Thick Film Resistors - SMD category](#):

Click to view products by [Viking manufacturer](#):

Other Similar products are found below :

[CRCW04028R20JNEE](#) [CRCW06036K80FKEE](#) [CRG1206F1K58](#) [CRL0603-FW-R700ELF](#) [M55342K06B6E19RWL](#) [RC1005F1072CS](#)
[RC1005F471CS](#) [RC1005F4751CS](#) [RCP0603W100RGED](#) [RCWP72251K47FKWB](#) [RLR05C7501GPB14](#) [RLR07C5111FSBSL](#) [ERJ-](#)
[1GMF1R00C](#) [ERJ-1GMF1R20C](#) [ERJ-1GMF2R55C](#) [ERJ-1GMF8R66C](#) [25121WF1003T4E](#) [25.501.3653.0](#) [290-1.0M-RC](#) [292-1.0M-RC](#) [292-](#)
[2.2K-RC](#) [292-4.7K-RC](#) [25121WF4700T4E](#) [292-470K-RC](#) [302-1.0M-RC](#) [CPG1206F10KC](#) [CRCW02011R00FXED](#) [CRCW060315K0FKEE](#)
[CRCW060320K5FKEE](#) [CRG0201F10K](#) [RCG0402150RFKED](#) [RCG04023K92FKED](#) [RCP2512B100RGWB](#) [RCWP110010R0FKS3](#)
[RCWP11002K00FKS3](#) [RCWP12061K00FKS2](#) [3520510RJT](#) [352075KJT](#) [M55342K11B9E53RUL](#) [RMC16-102JT](#) [RMC1JPTE](#) [TR0603MR-](#)
[075K1L](#) [5-2176094-4](#) [35202K7JT](#) [WF06Q1000FTL](#) [ERJ-S03J1R0V](#) [ERJ-S14J4R7U](#) [CHP2512L4R30GNT](#) [CPCC10270R0JE32](#)
[RCWP11001K00FKS3](#)