

Data Sheet

Customer :

Product : Resistor of Advanced Meter Thin Film Chip
Resistor - RAM Series

Size: 0402/0603/0805/1206/1210/2010/2512

Issued Date: 26-Oct-20

Edition : REV.A1



VIKING TECH CORPORATION
光韻科技股份有限公司

No.70, Guangfu N. Rad.,
Hsin Chu Industrial Park,
Hukou Hsiang, Hsin Chu Hsien,
303, Taiwan

TEL:886-3-5972931
FAX:886-3-5972935•886-3-5973494
E-mail:sales@viking.com.tw

VIKING TECH CORPORATION KAOHSIUNG BRANCH
光韻科技股份有限公司高雄分公司

No.248-3, Sin-Sheng Rd., Cian-Jhen Dist., Kaohsiung,
806, Taiwan

TEL:886-7-8217999
FAX:886-7-8228229
E-mail:sales@viking.com.tw

Viking Electronics (WUXI) CO., LTD.
光韻電子(無錫)有限公司

No.1A,(Xixia Road),Machinery & Industry Park,
National Hi-Tech Industrial Development Zone of
Wuxi, Wuxi, Jiangsu Province, China
Zip Code:214028

TEL:86-510-85203339
FAX:86-510-85203667•86-510-85203977
E-mail:wuxisales@tmtec.com.tw

Produced by (QC)	Checked (QC)	Approved by (QC)	Prepared by (Sales)	Accepted by (Customer)
26-Oct-20	26-Oct-20	26-Oct-20	26-Oct-20	
Chun	Ben Chang	Ben Chang		

Resistor of Advanced Meter Thin Film Chip Resistor (RAM Series)

■ Features

- Q/GDW 11179.3 Compliance
- Advanced thin film technology
- RoHS compliant
- Special materials, design, and processing for high sulfur applications
- Test proven immunity to humidity, moisture, and sulfur

■ Applications

- Smart meter
- Medical Equipment
- Testing / Measurement Equipment
- Advanced metering infrastructure



■ Construction

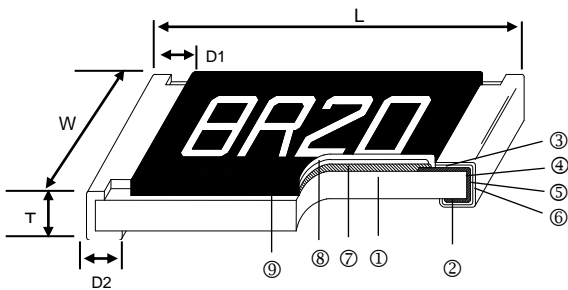

① Alumina Substrate	④ Edge Electrode	⑦ Resistor Layer
② Bottom Electrode	⑤ Barrier Layer	⑧ Overcoat
③ Top Electrode	⑥ External Electrode	⑨ Marking

■ Dimensions

Unit: mm

Type	Size (Inch)	L	W	T	D1	D2	Weight (g) (1000pcs)
RAM02	0402	1.00±0.05	0.50±0.05	0.30±0.05	0.20±0.10	0.30±0.10	0.54
RAM03	0603	1.55±0.10	0.80±0.10	0.45±0.10	0.30±0.20	0.45±0.20	1.83
RAM05	0805	2.00±0.15	1.25±0.15	0.55±0.10	0.30±0.20	0.55±0.20	4.71
RAM06	1206	3.05±0.15	1.55±0.15	0.55±0.10	0.42±0.20	0.50±0.25	9.02
RAM13	1210	3.10±0.15	2.40±0.15	0.55±0.10	0.40±0.20	0.60±0.25	10
RAM10	2010	4.90±0.15	2.40±0.15	0.55±0.10	0.60±0.30	0.65±0.25	23.61
RAM12	2512	6.30±0.15	3.10±0.15	0.55±0.10	0.60±0.30	0.65±0.25	38.06

■ Part Numbering

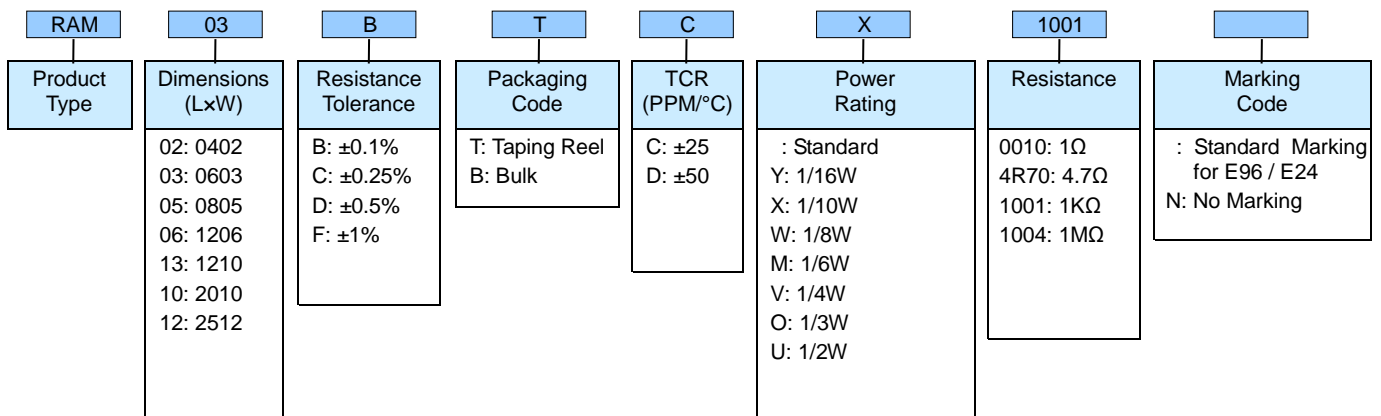

Derating Curve

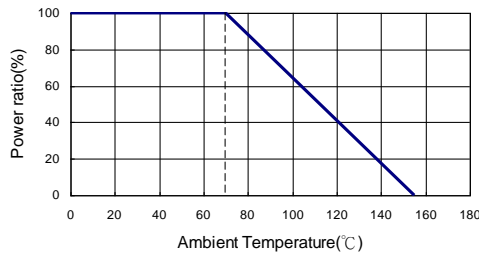

Standard Electrical Specifications

Type	Item	Power Rating at 70°C	Operating Temp. Range	Max. Operating Voltage	Max. Overload Voltage	Resistance Range				TCR (PPM/°C)
						±0.1%	±0.25%	±0.5%	±1%	
RAM02 (0402)		1/16W	-55 ~ +155°C	25V	50V	50Ω~100KΩ				±25,±50
RAM03 (0603)		1/16W	-55 ~ +155°C	50V	100V	1Ω~332KΩ				±25,±50
RAM05 (0805)		1/10W	-55 ~ +155°C	100V	200V	1Ω~1MΩ				±25,±50
RAM06 (1206)		1/8W	-55 ~ +155°C	150V	300V	1Ω~1MΩ				±25,±50
RAM13 (1210)		1/4W								
RAM10 (2010)		1/4W	-55 ~ +155°C	150V	300V	1Ω~1MΩ				±25,±50
RAM12 (2512)		1/2W								

High Power Rating Electrical Specifications

Type	Item	Power Rating at 70°C	Operating Temp. Range	Max. Operating Voltage	Max. Overload Voltage	Resistance Range				TCR (PPM/°C)
						±0.1%	±0.25%	±0.5%	±1%	
RAM03 (0603)		1/10W	-55 ~ +155°C	75V	150V	50Ω~100KΩ				±25,±50
RAM05 (0805)		1/8W	-55 ~ +155°C	150V	300V	1Ω~1MΩ				±25,±50
RAM06 (1206)		1/4W	-55 ~ +155°C	200V	400V	1Ω~1MΩ				±25,±50

Operating Voltage= $\sqrt{P \cdot R}$ or Max. operating voltage listed above, whichever is lower.
 Overload Voltage= $2.5 \cdot \sqrt{P \cdot R}$ or Max. overload voltage listed above, whichever is lower.

■Viking is capable of manufacturing the optional spec based on customer's requirement.

Environmental Characteristics

Item	Range	Requirement	Test Method
Temperature Coefficient of Resistance (T.C.R.)	As TCR Spec.		MIL-STD-202 Method 304 GB/T 5729-4.8 +25/-55/+25/+125/+25°C
Short Time Overload	$\Delta R \pm 0.2\%$		JIS-C-5201-1 4.13 Q/GDW 11179.3-7.2.3 RCWV*2.5 or Max. overload voltage whichever is lower for 5 seconds Measurement at 0.5 hours after test conclusion."
Endurance	$\Delta R \pm 0.2\%$		MIL-STD-202 Method 108A GB/T 5729-4.25.1 70±2°C, RCWV for 1000 hrs with 1.5 hrs "ON" and 0.5 hrs "OFF" Measurement at 2 hours after test conclusion."

Biased Humidity	96 hrs	$\Delta R \pm 0.2\%$	Q/GDW 11179.3-7.5.4 GB/T 5729-4.24 MIL-STD-202 Method 103 96 hrs 85°C/85%RH 10% of operating power. 96 hrs 85°C/85%RH No operating power. 1000 hrs 85°C/85%RH 10% of operating power. Measurement at 4 hours after test conclusion.
	1000 hrs	$\Delta R \pm 0.5\%$	
Solderability	95% min. coverage		Q/GDW 11179.3-7.4.1 MIL-STD-202 Method 208 Solder bath method; 245± 3°C for 5 seconds
Resistance to Soldering Heat	$\Delta R \pm 0.1\%$		Q/GDW 11179.3-7.4.2 GB/T 2423.28-5.4 260 ± 5°C for 5±1 seconds
High Temperature Exposure	96 hrs	$\Delta R \pm 0.1\%$	Q/GDW 11179.3-7.5.1 GB/T 5729-4.23.2 MIL-STD-202 Method 108 at +155°C Measurement at 4 hours after test conclusion.
	1000 hrs	$\Delta R \pm 0.3\%$	
Thermal Shock	$\Delta R \pm 0.5\%$		Q/GDW 11179.3-7.5.3 -40°C 30min , 85°C 30min, Temperature Change Time 2~3 min, 1 Cycle, Total 5 Cycles. Measurement at 16 hours after test conclusion.
Low Temperature Operation	$\Delta R \pm 0.2\%$		Q/GDW 11179.3- 7.5.5 1 hour, -45°C, followed by 45 minutes of RCWV 1 hour, -65°C, followed by 45 minutes of RCWV Measurement at 24 hours after test conclusion
Low Temperature Exposure	$\Delta R \pm 0.5\%$		Q/GDW 11179.3-7.5.2 GB/T 5729- 4.23.4 at -55°C for 96 hrs Measurement at 4 hours after test conclusion
Single pulse high voltage overload	$\Delta R \pm 0.5\%$		Q/GDW 11179.3- 8 GB/T 5729-2003 4.27 Class C:10* RCWV or 5*Max. Operating voltage whichever is lower
Vibration	$\Delta R \pm 0.5\%$		Q/GDW 11179.3- 7.3.2 GB/T 17215.211- 5.2.2.3 Vibration Frequency Range : 10Hz-150Hz crossover frequency: 60Hz f < 60Hz · uniform amplitude: 0.075mm f > 60Hz · Constant acceleration: 9.8m/ s ² (1g) Scanning cycles for every axis: 10 Note: 10 Scanning cycles-75min.

RCWV(Rated continuous working voltage)= $\sqrt{P \cdot R}$ or Max. Operating voltage whichever is lower

■ Storage Temperature: 15~28°C; Humidity < 80%RH

■ Soldering Condition

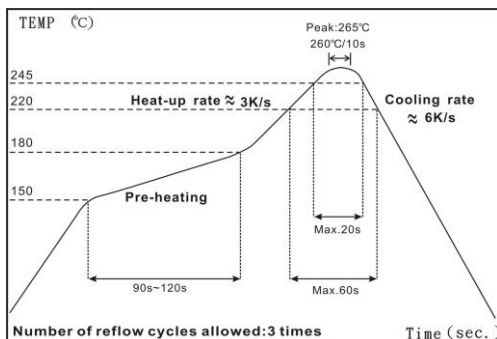

IR Reflow Soldering

- (1) Time of IR reflow soldering at maximum temperature point 260°C : 10s
- (2) Time of wave soldering at maximum temperature point 260°C : 10s

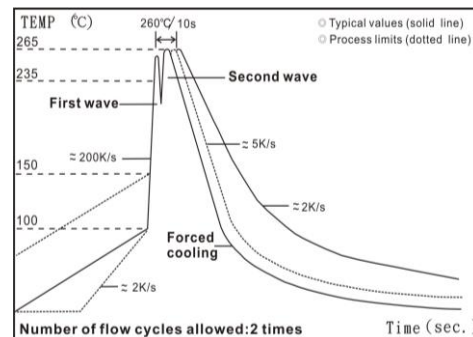

Wave Soldering (Flow Soldering)

(3) Time of soldering iron at maximum temperature point 410°C : 5s

■ Marking

0603 3digit marking

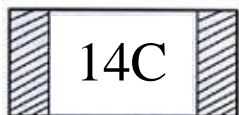

3digit marking for Example: 14C=13K7Ω 13C=13K3Ω
68B=4K99Ω 68X=49.9Ω

Marking Table

Code	E96	Code	E96	Code	E96	Code	E96				
01	100	25	178	49	316	73	562				
02	102	26	182	50	324	74	576				
03	105	27	187	51	332	75	590				
04	107	28	191	52	340	76	604				
05	110	29	196	53	348	77	619				
06	113	30	200	54	357	78	634				
07	115	31	205	55	365	79	649				
08	118	32	210	56	374	80	665				
09	121	33	215	57	383	81	681				
10	124	34	221	58	392	82	698				
11	127	35	226	59	402	83	715				
12	130	36	232	60	412	84	732				
13	133	37	237	61	422	85	750				
14	137	38	243	62	432	86	768				
15	140	39	249	63	442	87	787				
16	143	40	255	64	453	88	806				
17	147	41	261	65	464	89	825				
18	150	42	267	66	475	90	845				
19	154	43	274	67	487	91	866				
20	158	44	280	68	499	92	887				
21	162	45	287	69	511	93	909				
22	165	46	294	70	523	94	931				
23	169	47	301	71	536	95	953				
24	174	48	309	72	549	96	976				
Code	A	B	C	D	E	F	G	H	X	Y	Z
Multiplier	10 ⁰	10 ¹	10 ²	10 ³	10 ⁴	10 ⁵	10 ⁶	10 ⁷	10 ⁻¹	10 ⁻²	10 ⁻³

0603 3digit marking for E24

Example: 101=100Ω 102=1KΩ

E24	10	11	12	13	15	16	18	20	22	24	27	30	33	36	39	43	47	51	56	62	68	75	82	91
-----	----	----	----	----	----	----	----	----	----	----	----	----	----	----	----	----	----	----	----	----	----	----	----	----

0805~2512 4digit marking

Example

Resistance	100Ω	2.2KΩ	10KΩ	49.9KΩ	100KΩ
marking	1000	2201	1002	4992	1003

■Packaging

Packing Quantity & Reel Specifications

Unit :mm

Type	ØA	ØB	ØC	W	T	Paper Tape (EA)	Emboss Plastic Tape (EA)
RAM02	178.0±1.0	60.0+1.0	13.5±0.7	9.5±1.0	11.5±1.0	10,000	-
RAM03	178.0±1.0	60.0+1.0	13.5±0.7	9.5±1.0	11.5±1.0	5,000	-
RAM05	178.0±1.0	60.0+1.0	13.5±0.7	9.5±1.0	11.5±1.0	5,000	-
RAM06	178.0±1.0	60.0+1.0	13.5±0.7	9.5±1.0	11.5±1.0	5,000	-
RAM13	178.0±1.0	60.0+1.0	13.5±0.7	9.5±1.0	11.5±1.0	5,000	-
RAM10	178.0±1.0	60.0+1.0	13.5±0.7	13.5±1.0	15.5±1.0	-	4,000
RAM12	178.0±1.0	60.0+1.0	13.5±0.7	13.5±1.0	15.5±1.0	-	4,000



Paper Tape Specifications

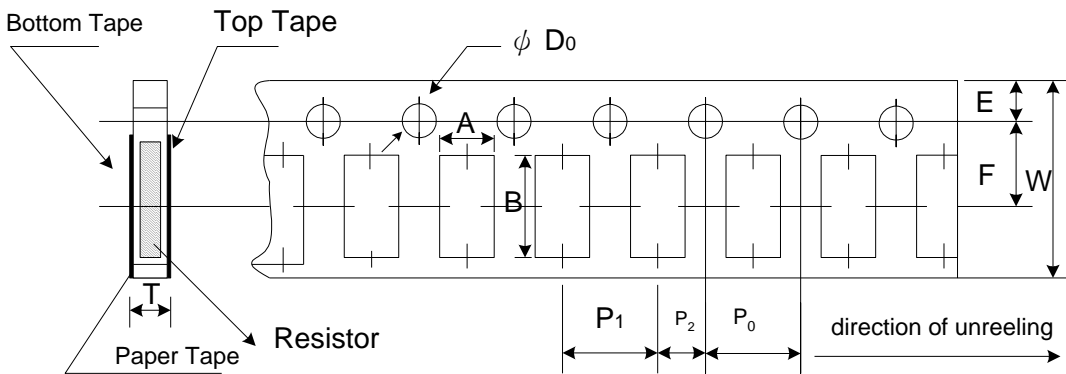

Unit: mm

Type	A	B	W	E	F	P ₀	P ₁	P ₂	ΦD ₀	T
RAM02	0.70±0.05	1.16±0.05	8.00±0.10	1.75±0.05	3.5±0.05	4.00±0.10	2.00±0.05	2.00±0.05	1.55±0.05	0.40±0.03
RAM03	1.10±0.05	1.90±0.05	8.00±0.10	1.75±0.05	3.5±0.05	4.00±0.10	4.00±0.10	2.00±0.05	1.55±0.05	0.60±0.03
RAM05	1.60±0.05	2.37±0.05	8.00±0.10	1.75±0.05	3.5±0.05	4.00±0.10	4.00±0.10	2.00±0.05	1.55±0.05	0.75±0.05
RAM06	2.00±0.05	3.55±0.05	8.00±0.10	1.75±0.05	3.5±0.05	4.00±0.10	4.00±0.10	2.00±0.05	1.55±0.05	0.75±0.05
RAM13	2.75±0.05	3.40±0.05	8.00±0.10	1.75±0.05	3.5±0.05	4.00±0.05	4.00±0.10	2.00±0.05	1.60±0.10	0.75±0.05

- Peel force of top cover tape
- The peel speed shall be about 300mm/min±5%
- The peel force of top cover tape shall be between 8gf to 60gf

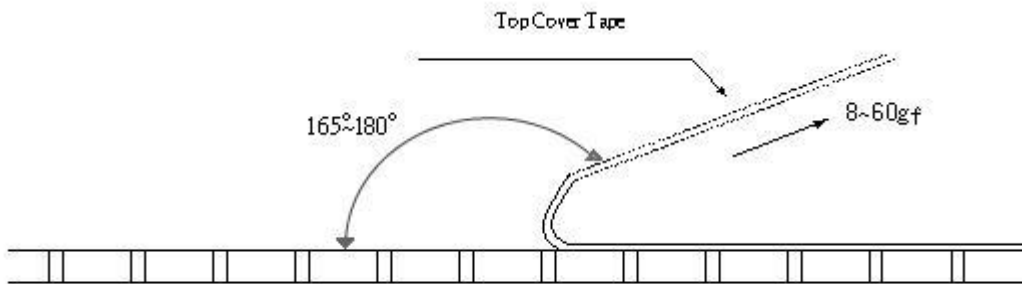

Emboss Plastic Tape Specifications

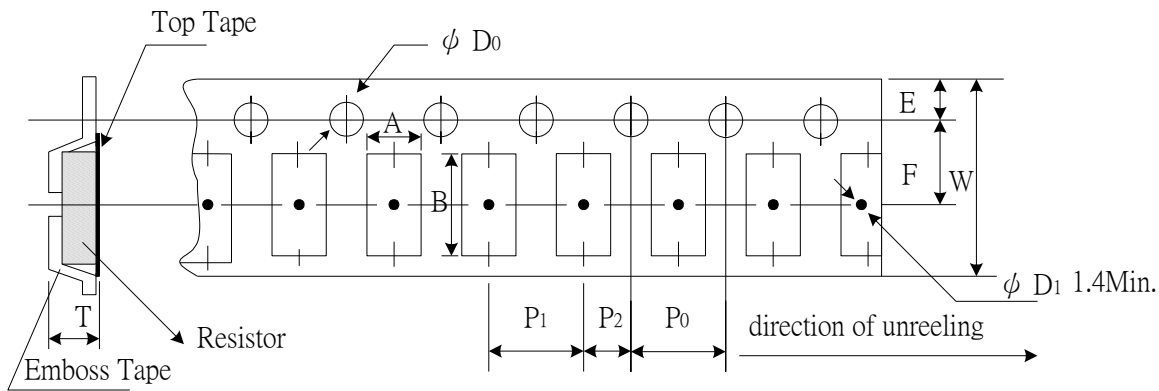

Unit: mm

Type	A	B	W	E	F	P ₀	P ₁	P ₂	ØD ₀	T
RAM10	2.85±0.10	5.45±0.10	12.0±0.10	1.75±0.10	5.5±0.05	4.00±0.05	4.00±0.10	2.00±0.05	1.50±0.10	1.00±0.20
RAM12	3.40±0.10	6.65±0.10	12.0±0.10	1.75±0.10	5.5±0.05	4.00±0.05	4.00±0.10	2.00±0.05	1.50±0.10	1.00±0.20

- Peel force of top cover tape
- The peel speed shall be about 300mm/min±5%
- The peel force of top cover tape shall be between 20gf to 80gf

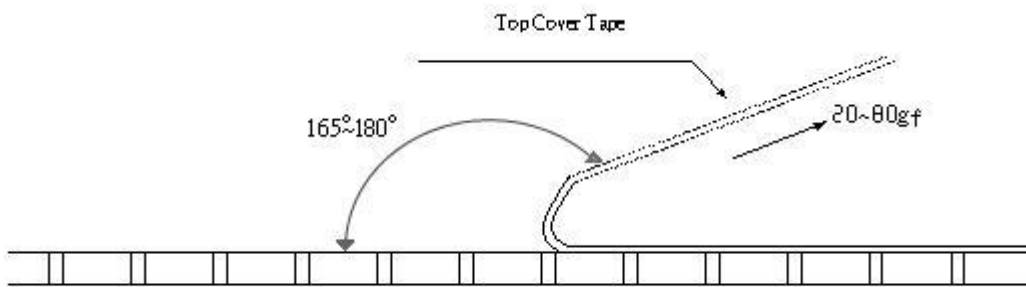

Recommend Land Pattern

Unit: mm

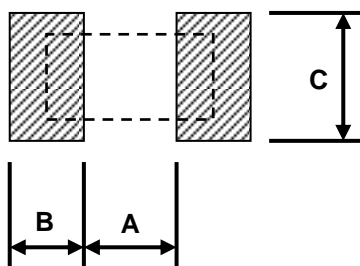

Type	A	B	C
RAM02	0.50	0.50	0.60±0.2
RAM03	0.80	1.00	0.90±0.2
RAM05	1.00	1.00	1.35±0.2
RAM06	2.00	1.15	1.70±0.2
RAM13	2.00	1.15	2.50±0.2
RAM10	3.60	1.40	2.50±0.2
RAM12	4.90	1.60	3.10±0.2

X-ON Electronics

Largest Supplier of Electrical and Electronic Components

Click to view similar products for [Thick Film Resistors - SMD category](#):

Click to view products by [Viking manufacturer](#):

Other Similar products are found below :

[CR-05FL7--150R](#) [CR-05FL7--698K](#) [CR-12JP4--680R](#) [CRCW04021K20FKEE](#) [CRCW04028R20JNEE](#) [CRCW06032K10FKEC](#)
[CRCW06036K80FKEE](#) [M55342K03B499DRS6](#) [M55342K06B6E19RWL](#) [M55342K09B5D62RS6](#) [M55342M06B26E7RS3](#) [742C083750JTR](#)
[MCR01MZPF1202](#) [MCR01MZPF1601](#) [MCR01MZPF1800](#) [MCR01MZPF6201](#) [MCR01MZPF9102](#) [MCR01MZPJ121](#) [MCR01MZPJ125](#)
[MCR01MZPJ751](#) [MCR03EZHJ103](#) [MCR03EZPFX2004](#) [MCR03EZPJ270](#) [MCR03EZPJ821](#) [MCR10EZPF1102](#) [MCR10EZPF2700](#)
[MCR18EZPJ330](#) [RC1005F1152CS](#) [RC1005F1372CS](#) [RC1005F1912CS](#) [RC1005F2052CS](#) [RC1005F3011CS](#) [RC1005F471CS](#)
[RC1005F4751CS](#) [RC1005F5621CS](#) [RC1005F6041CS](#) [RC1005J121CS](#) [RC1005J122CS](#) [RC1005J154CS](#) [RC1005J180CS](#) [RC1005J181CS](#)
[RC1005J202CS](#) [RC1005J391CS](#) [RC1005J560CS](#) [RC1005J683CS](#) [RC1005J823CS](#) [RC1608F1022CS](#) [RC1608F333CS](#) [RC1608F3651CS](#)
[RC1608F5110CS](#)