



Document Title

64Mbit Serial SRAM Specification

Revision History

Revision No.	History	Date	Remark
0.1	Initial Draft	March. 31 2017	Preliminary

1. General Description

This document defines “64Mbit Serial SRAM”, which support 1.8v & 3.0V 64Mbit of SPI/QPI (Serial Peripheral Interface/Quad Peripheral Interface) SRAM device. This RAM is configurable as 1 bit Input and Output separate or 4 bit I/O common interface. All of necessary Refresh operation is taken care by device itself.

Features

- SPI Bus Interface:
 - SPI compatible
 - SQI(qual) compatible
 - 20 MHz Clock rate for all mode
- Low-Power CMOS Technology:
 - Read Current: Max.25mA
 - Standby Current: Typical 50uA
- Unlimited Read and Write Cycles
- 8M x 8-bit Organization & 1Kbytes page size
- High Reliability
- RoHS Compliant
- 8 Lead SOIC Package
- Temperature Ranges Supported:
 - Extended(E): -25°C to +85°C
 - Industrial(I): -40°C to +85°C

Product Family

Part Number	Temperature Ranges	Power Supply	Packages
VTI7064LSME	E	1.6V~2.0V	8pin SOIC
VTI7064LSMI	I	1.6V~2.0V	8pin SOIC
VTI7064MSME	E	2.7V~3.3V	8pin SOIC
VTI7064MSMI	I	2.7V~3.3V	8pin SOIC

2. Pin Description

8pin SOIC 150mil

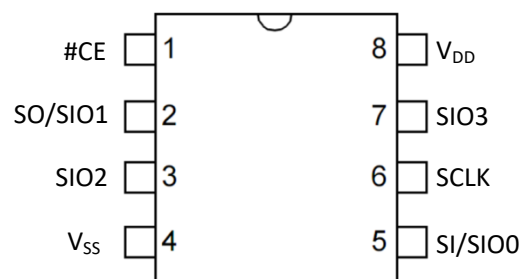

Symbol	Signal Type	SPI Mode	QPI Mode
V _{DD}	Power	Core Power Supply	
V _{SS}	Ground	Core Supply Ground	
CE#	Input	Chip select signal, Active Low. When CE# input is High, memory will be in Standby state	
CLK	Input	Clock Signal	
SI/SIO[0]	I/O	Serial Input	I/O[0]
SO/SIO[1]	I/O	Serial Output	I/O[1]
SIO[3:2]	I/O	I/O[3:2] ¹	I/O[3:2]

Note:1, Fast read Quad access and Quad Write access in SPI Mode use SIO[3:2]. Recommend to pull down to GND if no use of SIO[3:2] in SPI mode.

3. Power up initialization

All products include an on-chip voltage sensor used to start the self-initialization process. When V_{DD} reaches a stable level at or above minimum V_{DD}, the device will require 150µs to complete its self-initialization process. From the beginning of power ramp to the end of the 150µs period, CLK should remain LOW, CE# should remain HIGH (track V_{DD} within 200mV) and SI/SO/SIO[3:0] should remain LOW.

After the 150us period the device requires initialization command sequence as it's shown in Figure 2, and then the device is ready for normal operation.

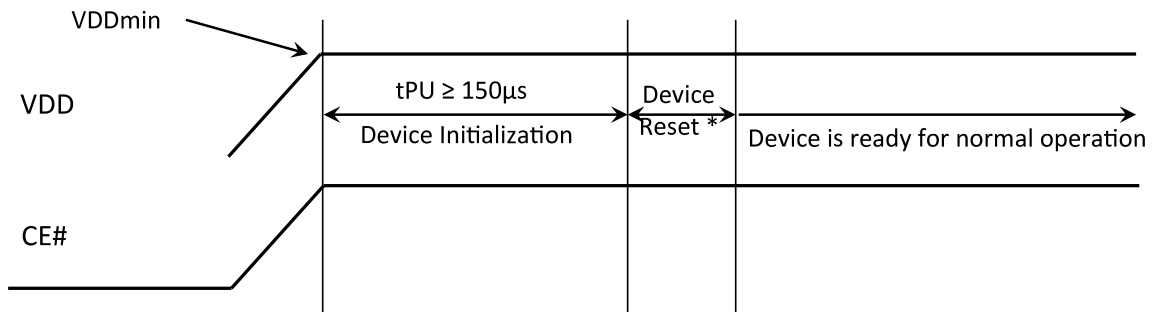

Figure 1. Power-Up Initialization Timing

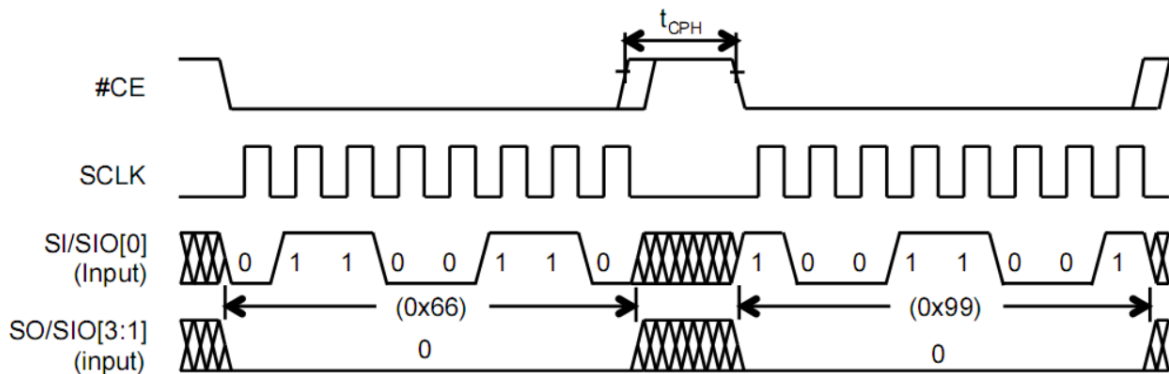

Figure 2. Reset command sequence for Device Initialization

4.Interface Description

4.1 Address Space

All devices are byte-addressable. 64M device is addressed with A[22:0].

4.2 Page Length

Read and write operations are always linear address space. The Linear Burst can cross page boundary as long as tCEM(max.) is met.

4.3 Drive Strength

The device powers up in 50Ω.

4.4 Power-on Status

The device powers up in SPI Mode.

It is required to have CE# high before beginning any operations.

4.5 Command/Address Latching Truth

The device recognizes the following commands specified by the various input methods

Command	Code	SPI Mode(QE=0)					QPI Mode(QE=1)				
		Cmd	Addr	Wait Cycle	DIO	Max Freq.	Cmd	Addr	Wait Cycle	DIO	Max Freq.
Read	0x03	S	S	0	S	33	N.A.	N.A.	N.A.	N.A.	N.A.
Fast Read	0x0B	S	S	8	S	104	Q	Q	4	Q	84
Fast Read Quad	0xEB	S	Q	6	Q	104	Q	Q	6	Q	104
Write	0x02	S	S	0	S	104	Q	Q	0	Q	104
Quad Write	0x38	S	Q	0	Q	104	same as 0x02				
Enter Quad Mode	0x35	S	-	-	-	104	N.A.	N.A.	N.A.	N.A.	N.A.
Exit Quad Mode	0xF5	N.A.	N.A.	N.A.	N.A.	N.A.	Q	-	-	-	104
Reset Enable	0x66	S	-	-	-	104	Q	-	-	-	104
Reset	0x99	S	-	-	-	104	Q	-	-	-	104
Read ID	0x9F	S	S	0	S	104	N.A.	N.A.	N.A.	N.A.	N.A.

Remark: S = Serial IO, Q = Quad IO

4.6 Command termination

All All Reads & Writes must be completed by CE# LOW to HIGH. This CK# rising edge is the trigger to terminate the activated wordline for the read/write and set the device into standby. Not doing so will block internal refresh operations until the device sees the read/write wordline terminated. Command termination operation is necessary not only for Reads & Write operation and also any command operation, such as Enter Quad mode command and Reset commands.

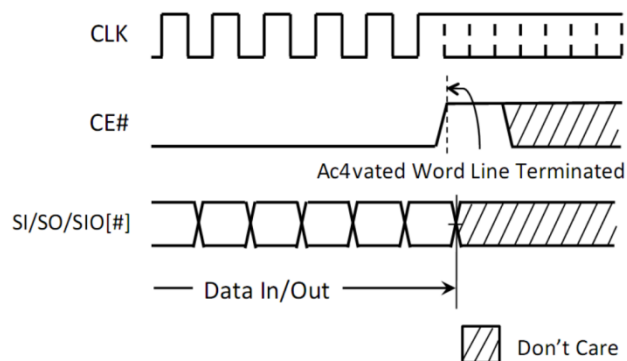

Figure 3

5. SPI Mode Operations

The device powers up into SPI mode by default but can also be switched into QPI mode.

5.1 SPI Read Operations

All read operation, data will be available t_{ACLK} after the falling edge of CLK. SPI read operation can be done in three ways:

- 1) 0x03: Serial CMD, Serial IO, slow frequency
- 2) 0x0B: Serial CMD, Serial IO, fast frequency
- 3) 0xEB: Serial CMD, Quad IO, fast frequency

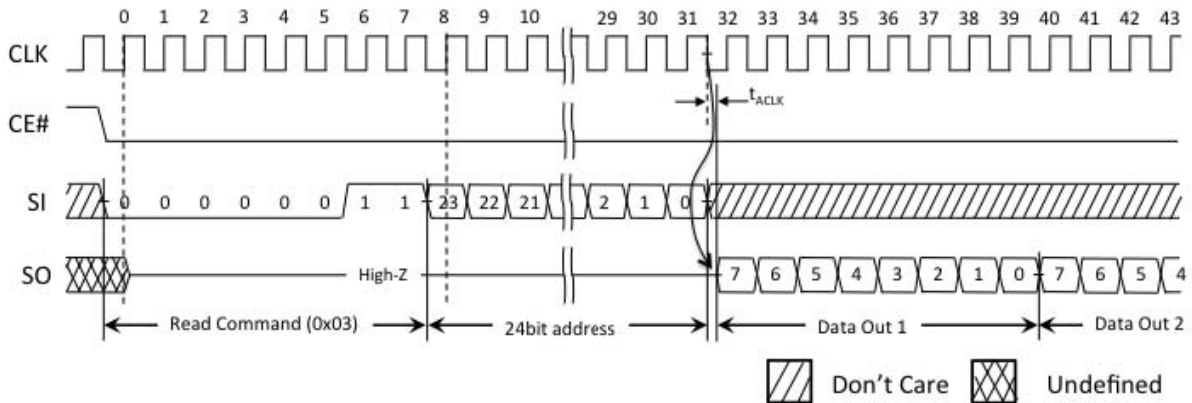

Figure 4: SPI Read 0x03 (max frequency @ 33MHz)

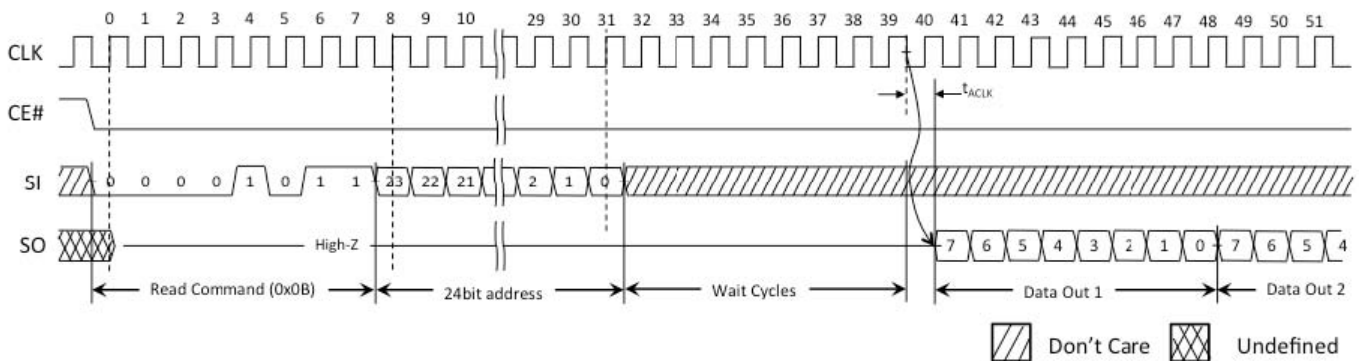
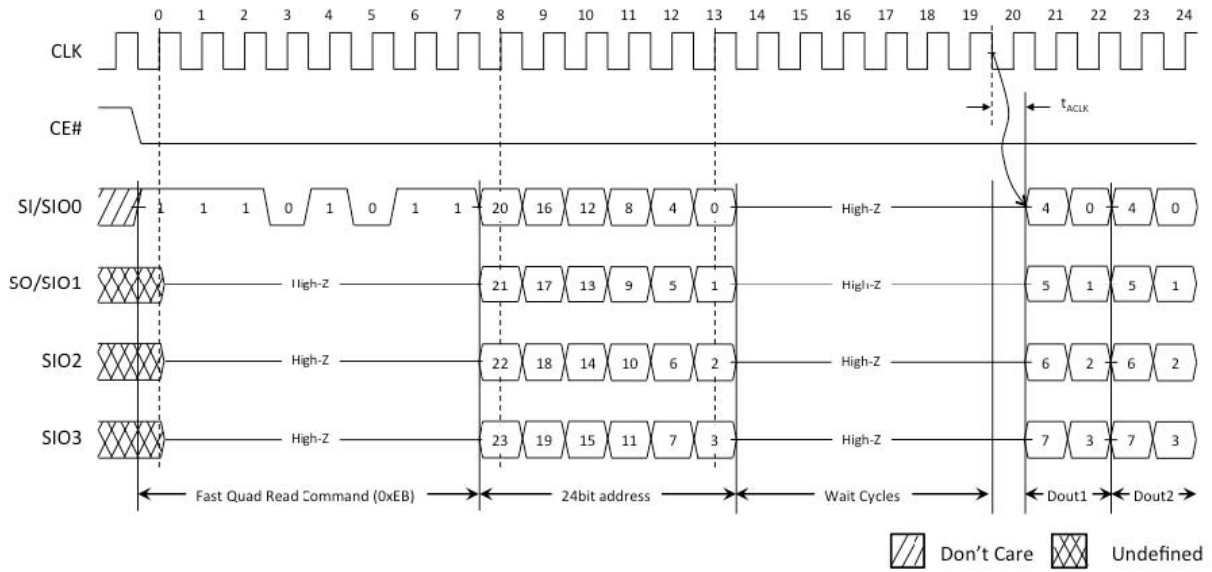
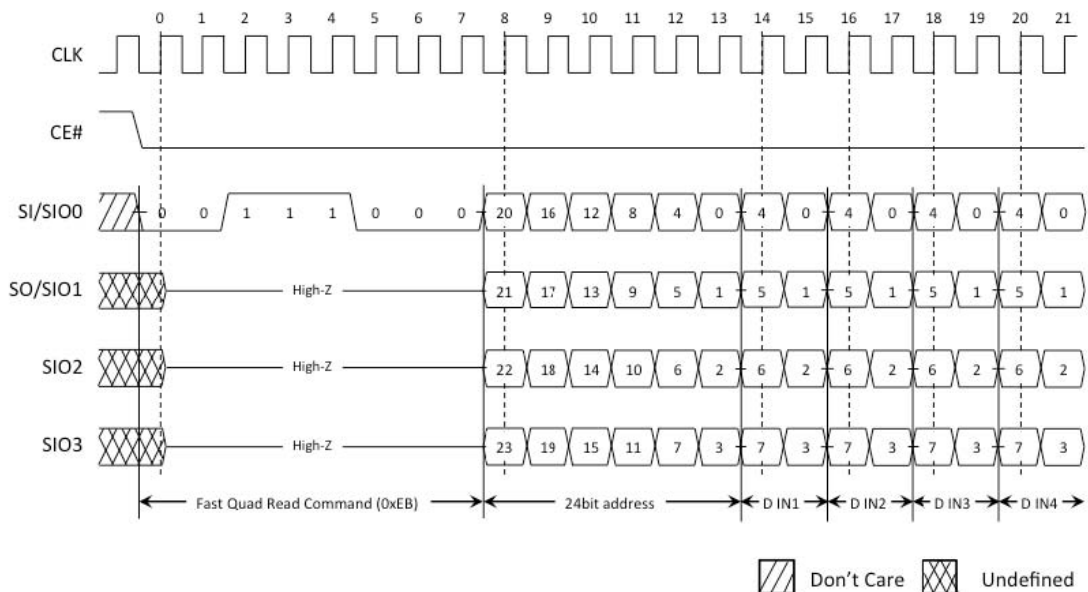
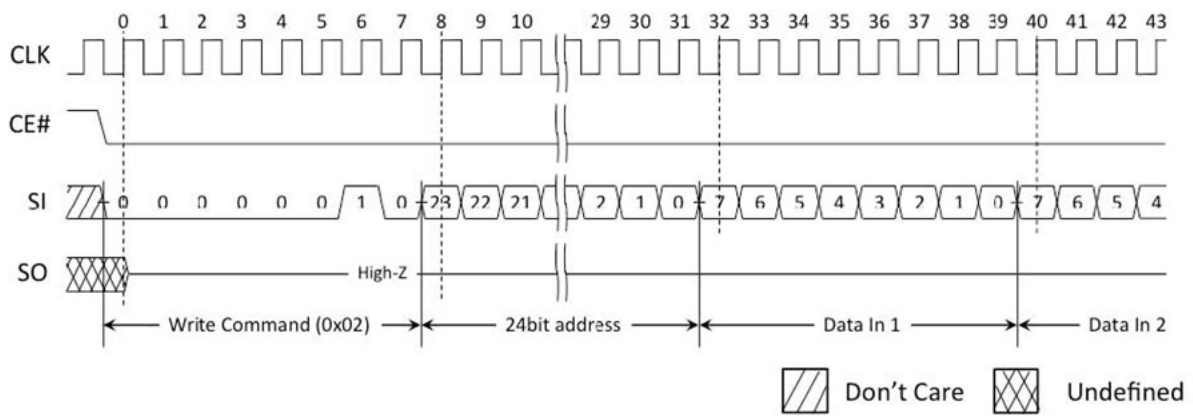

Figure 5: SPI Fast Read 0x0B (max frequency @ 104MHz)



5.2 SPI Write Operations



5.3 SPI to QPI Mode Enable Operation

This command switches the device into QPI mode.

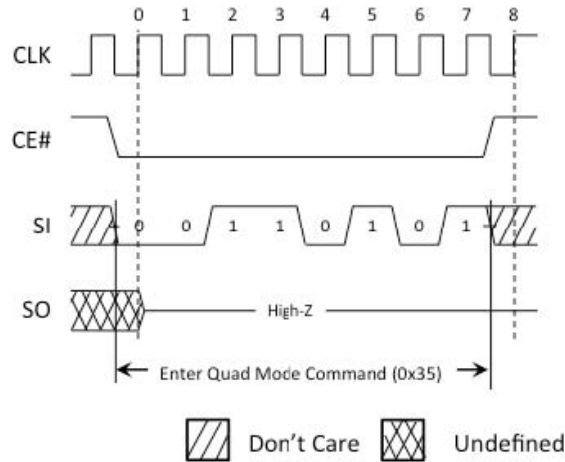

Figure 9. Quad Mode Enable 0x35

5.4 SPI Read ID Operation

This command is similar to Fast Read, but without the wait cycles and the device outputs EID value instead of data.

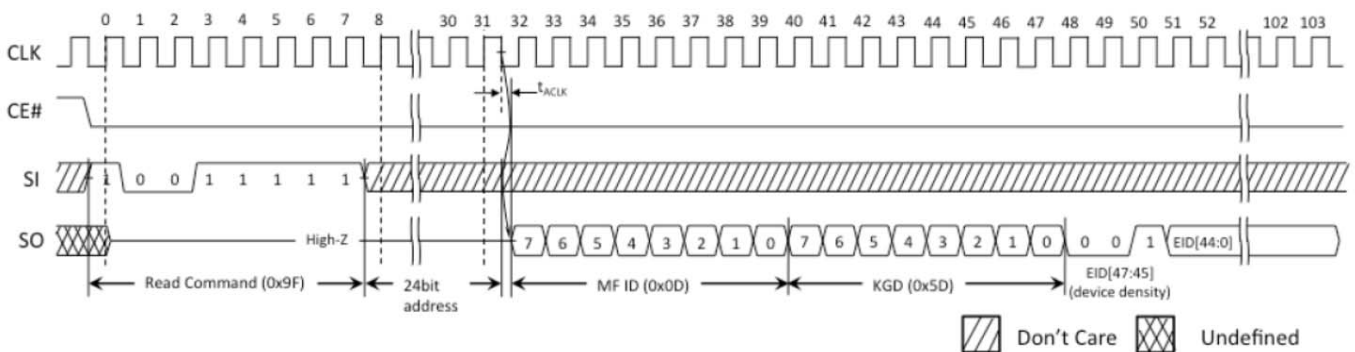

Figure 10 : SPI Read ID 0x9F (available only in SPI mode)

6.QPI Mode Operations

6.1 QPI Read Operations

All read operation, data will be available t_{ACLK} after the falling edge of CLK. QPI read operation can be done in one of two ways:

- 1) 0x0B : Quad CMD, Quad IO, slow frequency
- 2) 0xEB : Quad CMD, Quad IO, fast frequency

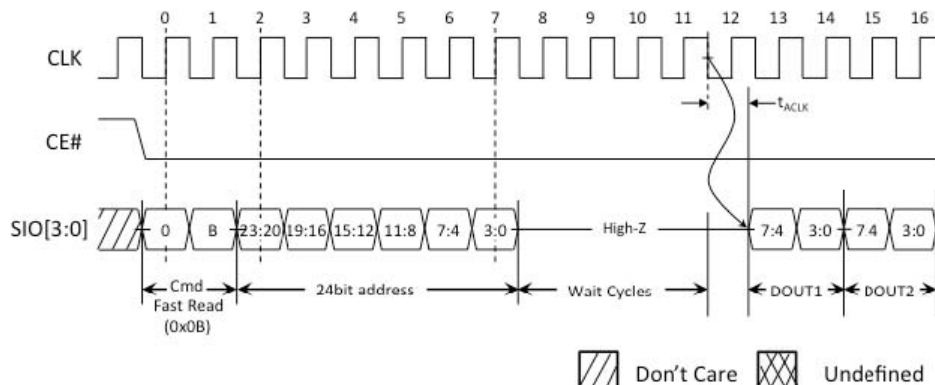

Figure 11 : QPI Fast Read 0x0B (max frequency 84Mhz)

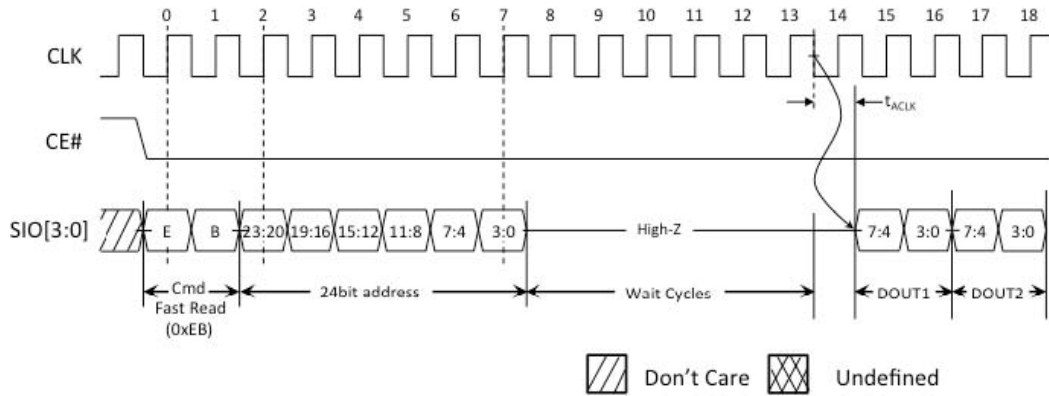

Figure 12 : QPI Fast Read 0xEB (max frequency 104Mhz)

6.2 QPI Write Operations

QPI write command can be input as 0x02 or 0x38. It does not matter Clock frequency.

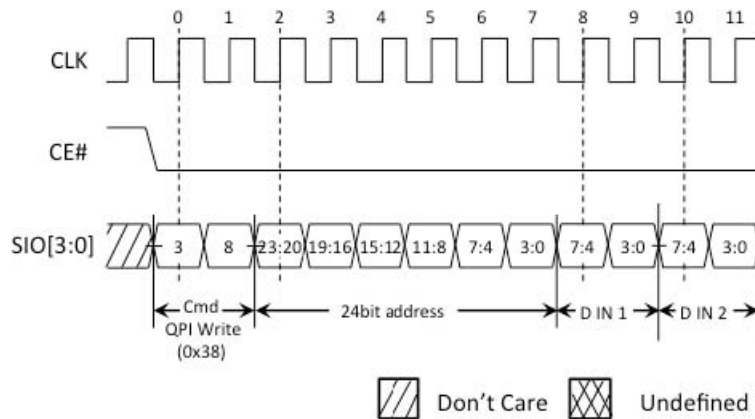

Figure 13 : QPI Write 0x02 or 0x38

6.3 QPI Mode Exit Operation

This command will switch the device back into SPI mode.

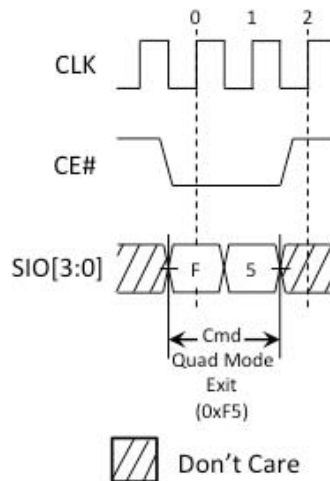

Figure 14 : Quad Mode Exit 0xF5 (Only available in QPI mode)

7.Reset Operation

The Reset operation is used as a system (software) reset that puts the device in SPI standby mode which is also the default mode after power up. This operation consists of two commands: Reset Enable (RSTEN) and Reset (RST).

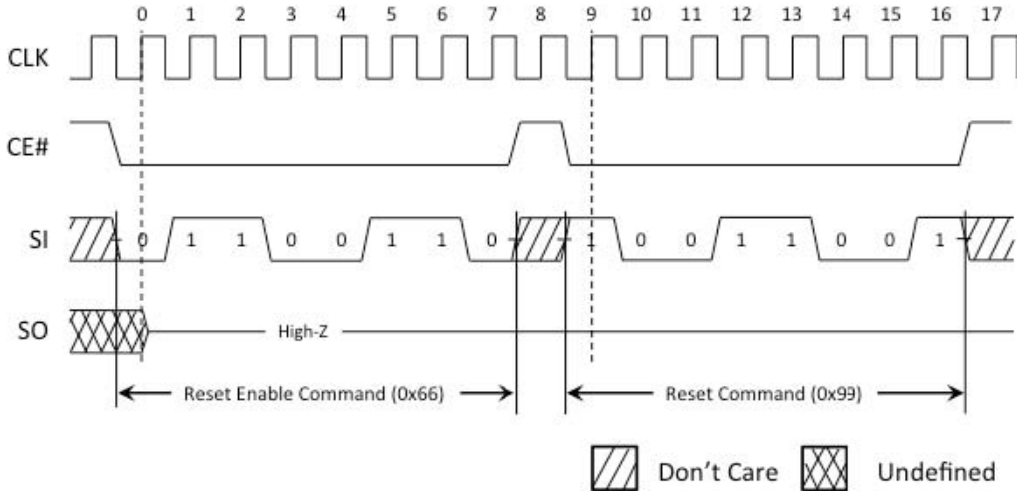

Figure 15. SPI Reset

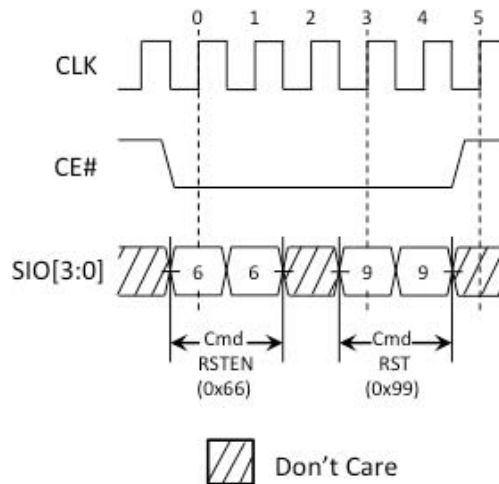

Figure 16 : QPI Reset

The Reset operation requires the Reset Enable command followed by the Reset command. Any command other than the Reset command after the Reset Enable command will disable the Reset Enable procedure.

8. Input / Output Timing

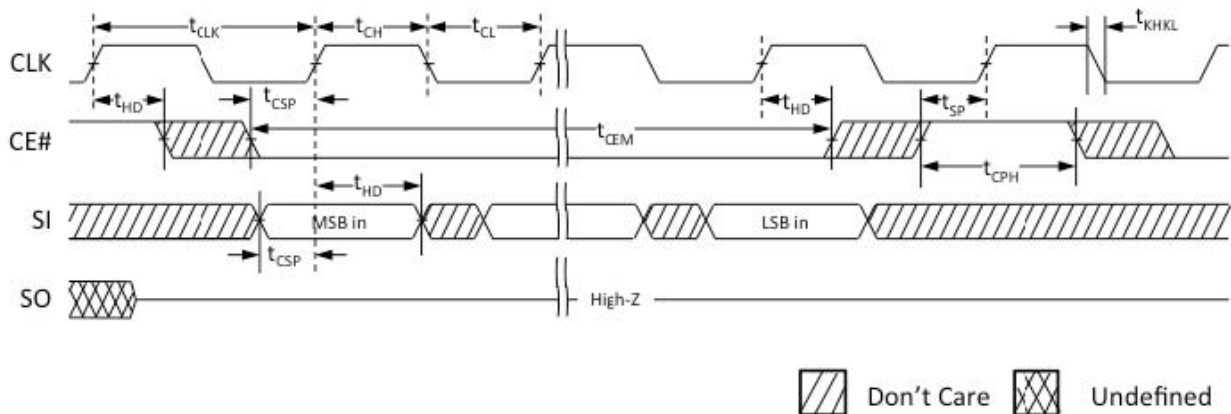

Figure 17: Input Timing

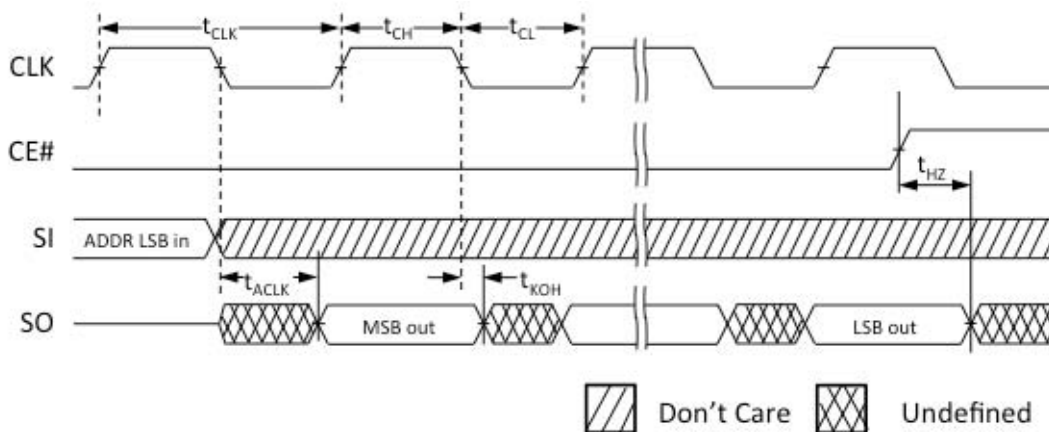

Figure 18: Output Timing

9. Electrical Specifications:

9.1 Absolute Maximum Ratings

Parameter	Symbol	Rating	Unit	Notes
Voltage to any ball except V_{DD} relative to V_{SS}	VT	-0.3 to $V_{DD}+0.3$	V	
Voltage on V_{DD} supply relative to V_{SS}	V_{DD}	-0.2 to +2.45	V	
Storage Temperature	TSTG	-55 to +150	°C	1

Notes 1: Storage temperature refers to the case surface temperature on the center/top side of the SRAM.

2: Exposing the device to stress above those listed in Absolute Maximum Ratings could cause permanent damage. The device is not meant to be operated under conditions outside the limits described in the operational section of this specification. Exposure to Absolute Maximum Rating conditions for extended periods may affect device reliability.

9.2 Operating Conditions

Parameter	Min	Max	Unit	Notes
Operating Temperature (standard)	-25	+85	°C	



9.3 DC Characteristics

Symbol	Parameter	Min	Typ.	Max	Unit	Notes
V _{DD}	Supply Voltage	VTI7064Lxx	1.60	1.8	2.0	V
		VTI7064Mxx	2.7	3.0	3.3	V
V _{IH}	Input high voltage	V _{DD} -0.4	-	V _{DD} +0.2	V	
V _{IL}	Input low voltage	-0.2	-	0.4	V	
V _{OH}	Output high voltage (I _{OH} =-0.2mA)	0.8 V _{DD}	-	-	V	
V _{OL}	Output low voltage (I _{OL} =+0.2mA)	-	-	0.2 V _{DD}	V	
I _{LI}	Input leakage current	-	-	1	uA	
I _{LO}	Output leakage current	-	-	1	uA	
I _{CC}	Read/Write	-	-	25	mA	
I _{SB}	Standby current	VTI7064Lxx	-	50	-	uA
		VTI7064Mxx	-	60	-	uA

9.4 AC Characteristics

Symbol	Parameter	Min	Max	Unit	Notes
t _{CLK}	CLK period-SPI Read (0x03) @33MHz	30.3	-	ns	
	CLK period-QPI Fast Read (0x0B) @84MHz	11.9	-	ns	
	CLK period-all other operations @104MHz	9.6	-	ns	
t _{CH} /t _{CL}	Clock high/low width	0.45	0.55	t _{CLK}	
t _{KHKL}	CLK rise or fall time	-	1.5	ns	
t _{CPH}	CE# HIGH between subsequent burst operations	1	-	t _{CLK}	
t _{CEM}	CE# low pulse width	-	4	μs	
t _{CSP}	CE# setup time to CLK rising edge	3	-	ns	
t _{SP}	Setup time to active CLK edge	2.5	-	ns	
t _{HD}	Hold time from active CLK edge	2	-	ns	
t _{HZ}	Chip disable to DQ output high.Z	-	7	ns	
t _{ACLK}	CLK to output delay	-	7	ns	
t _{KOH}	Data hold time from clock falling edge	1.5	-	ns	

10.Code Information:

V	T	I	X	X	X	X	X	X	X	X	X	X	X
1	2	3	4	5	6	7	8	9	10	11	12	13	14

Digit-No.	Remark	Code	
1,2,3	Vilson Technology Inc. Product	VTI	
4	Serial SRAM	7	
5,6,7	Density	16Mb	016
		32Mb	032
		64Mb	064
8	Vcc	1.8V	L
		3.0V	M
		3.3V	N
9	Package	8 SOIC	S
		8 TSSOP	T
		8 DIP	D
10	Die Version	Monther Die	M
		2nd Generation	A
		3rd Generation	B
11	Temperature range	-25°C to 85°C	E
		-40°C to 85°C	I
		-40°C to 125°C	A
12	Packing type	Tube	Blank
		Tape and Reel	T
13, 14	Special function	TBD	TBD

11.Package Information

8pin SOIC(150mil)

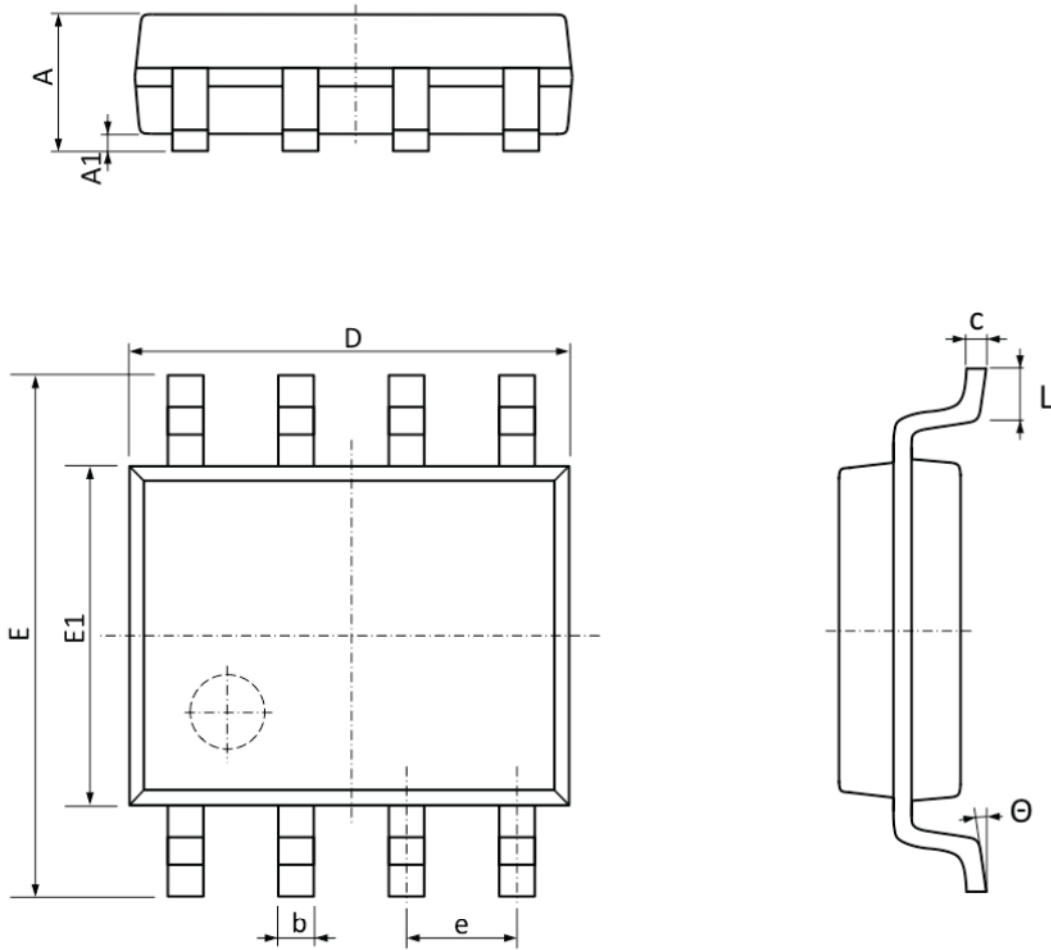

Symbol	Min	Max
A	1.35	1.75
A1	0.10	0.25
b	0.33	0.51
c	0.15	0.25
D	4.75	5.05
E1	3.80	4.00
E	5.80	6.20
e	1.27 (TYP.)	
L	0.40	0.80
⊙	0°	8°

Unit:mm

X-ON Electronics

Largest Supplier of Electrical and Electronic Components

Click to view similar products for [SRAM](#) category:

Click to view products by [Vilsion](#) manufacturer:

Other Similar products are found below :

[CY6116A-35DMB](#) [CY7C1049GN-10VXI](#) [CY7C1461KV33-133AXI](#) [GS8161Z36DD-200I](#) [GS88237CB-200I](#) [RMLV0408EGSB-4S2#AA0](#)
[IS64WV3216BLL-15CTLA3](#) [IS66WVE4M16ECLL-70BLI](#) [PCF8570P](#) [K6F2008V2E-LF70000](#) [K6T4008C1B-GB70](#) [CY7C1353S-100AXC](#)
[AS6C8016-55BIN](#) [AS7C164A-15PCN](#) [515712X](#) [IS62WV51216EBLL-45BLI](#) [IS63WV1288DBLL-10HLI](#) [IS66WVE2M16ECLL-70BLI](#)
[IS66WVE4M16EALL-70BLI](#) [IS61WV102416DBLL-10TLI](#) [CY7C1381KV33-100AXC](#) [CY7C1460KV25-200BZI](#) [CY7C1373KV33-100AXC](#)
[CY7C1381KVE33-133AXI](#) [CY7C4121KV13-600FCXC](#) [GS882Z18CD-150I](#) [IS61WV102416DBLL-10BLI](#) [IS66WVC2M16ECLL-7010BLI](#)
[7140LA35PDG](#) [CY7C1380KV33-250AXC](#) [AS6C8016-55BINTR](#) [CY7C1370KV33-250AXC](#) [CY7C1370KVE33-167AXI](#) [AS7C34096B-](#)
[10TIN](#) [AS6C8016-55TIN](#) [IS62WV25616EALL-55TLI](#) [GS8128418B-167IV](#) [CY7C1460KV25-200BZXI](#) [CY7C1460KV25-167BZXI](#)
[CY7C1315KV18-333BZXC](#) [CY7C1370KV25-200AXC](#) [71421LA55JI8](#) [CY62157G30-45ZSXI](#) [RMLV3216AGSD-5S2#AA0](#)
[R1RP0416DGE-2PR#B0](#) [CY62126EV18LL-70BVXI](#) [CY62128ELL-45SX](#) [CY62146G30-45ZSXA](#) [CY7C016A-15AXC](#) [CY7C1380KV33-](#)
[167AXC](#)