





产品图片	Features 产品特性	Application 应用
 <b>DIP8</b>   <b>SMD8</b>	<ul style="list-style-type: none"> <li>●Contact Form 触点形式 2a</li> <li>●Load Voltage 输出电压 60V</li> <li>●Load Current 输出电流 1.1A</li> <li>●Low Off-State Leakage Current 漏电流 1μA</li> </ul>	<ul style="list-style-type: none"> <li>●Automatic Test Equipment 自动检测设备</li> <li>●Telephone Equipment 通信设备</li> <li>●Sensing Equipment 传感设备</li> <li>●Security Equipment 安全设备</li> <li>●I/O Modules I/O 模块</li> <li>●Modem 调制解调器</li> </ul>

## Type 种类

Output rating 输出额定		Marking model 标刻型号	Part No. 订货型号	
Load voltage 负载电压	Load current 负载电流		DIP 双列直插	SMD 表面贴装
60V	1.1A	BCW252A	BCW252	BCW252A

注：表示引脚类型的“A”未标刻在产品上，订货依据订货示例型号。

## Dimensions 外形尺寸

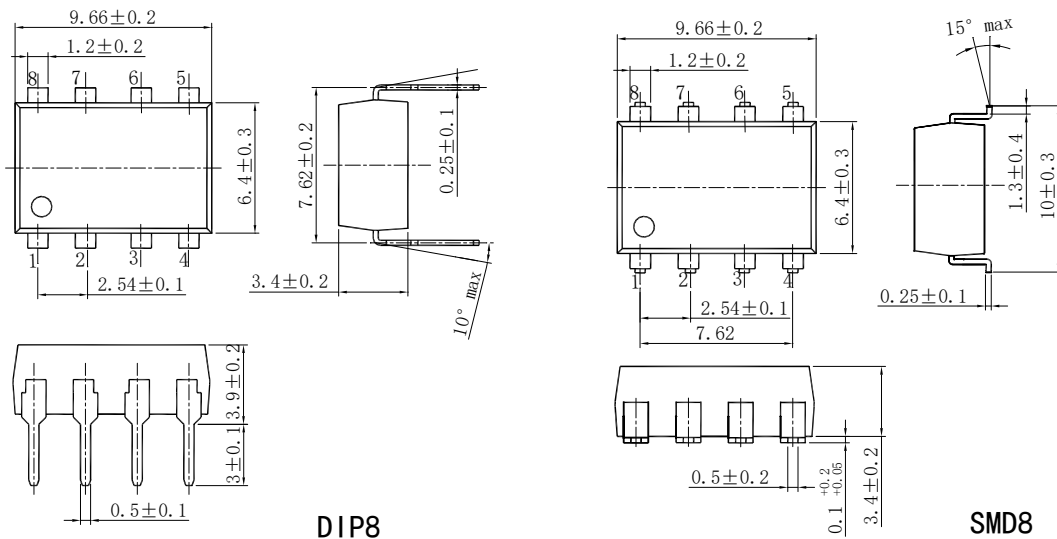

## Terminal Identification 引脚标识

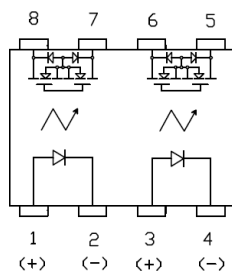

## Wiring Diagram

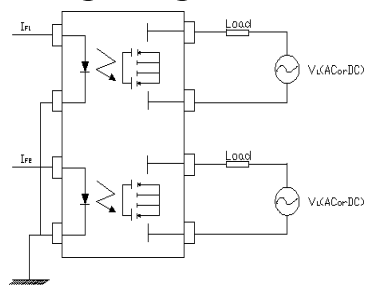

通讯地址：陕西省西安市国家民用航天产业基地航天中路385号众创广场11层1101.1102.1104室

生产地址：陕西省宝鸡市陈仓区群力路1号邮政编码：721300

电话：(0917)-6293969 18609177833

传 真：(0917)-6293969



# PhotoMOS 光 MOS 继电器 (SMD8/DIP8)

## Technical parameters 技术参数 (Ambient Temperature 25°C)

I/O Absolute Maximum Ratings 输入输出电气参数最大值

Item 项目		Symbol 符号	BCW252A	
Operating Temperature 工作温度		$T_{OPR}$	-40°C~+85°C	
Storage Temperature 储存温度		$T_{STG}$	-40°C~+100°C	
Input 输入	Continuous LED Current 工作电流	MAX. 最大值	$I_F$	50mA
	Peak LED Current LED 峰值电流 (f=100Hz, Duty=1%)	MAX. 最大值	$I_{FP}$	500mA
	LED Reverse Voltage 反向电压	MAX. 最大值	$V_R$	5V
	Input Power Dissipation 输入功耗	MAX. 最大值	$P_{IN}$	75mW
Output 输出	Load Voltage 输出电压	MAX. 最大值	$V_L$	60V (AC peak or DC)
	Load Current 输出电流	MAX. 最大值	$I_L$	1.1A
	Peak Load Current 峰值输出电流 (100ms, 1shot)	MAX. 最大值	$I_{PEAK}$	2.5A
	Output Power Dissipation 输出功耗	MAX. 最大值	$P_{OUT}$	450mW
Total Power Dissipation 总功耗		MAX. 最大值	$P_T$	500mW
I/O Breakdown Voltage 输入输出间隔离电压		MAX. 最大值	$V_{I/O}$	3750Vrms

Electrical Specifications 输入输出电气参数

Item 项目		Symbol 符号	BCW252A	Conditions 条件	
Input 输入	LED Forward Voltage 正向电压	TYP. 典型值	1.3V	$I_F=10mA$	
		MAX. 最大值	1.4V		
	Operation LED Current 接通电流	TYP. 典型值	1.7mA		
		MAX. 最大值	5mA		
Recovery LED Voltage 关断电压	MIN. 最小值	$V_{F OFF}$	0.5V		
Output 输出	On-Resistance 导通电阻	TYP. 典型值	0.27Ω	$I_F=5mA, I_L=100mA,$ within 1 sec.	
		MAX. 最大值	0.7Ω		
	Off-State Leakage Current 漏电流	MAX. 最大值	$I_{LEAK}$	1μA	$V_L=Rating$
Output Capacitance 输出端容量	TYP. 典型值	$C_{OUT}$	76pF	$V_L=0V, f=1MHz$	
Timeparameters 时间参数	Turn-On Time 接通时间	TYP. 典型值	0.7ms	$I_F=5mA, I_L=100mA$	
		MAX. 最大值	5ms		
	Turn-Off Time 关断时间	TYP. 典型值	0.05ms		
		MAX. 最大值	2ms		
I/O 输入输出	I/O Insulation Resistance 绝缘电阻	MIN. 最小值	$R_{I/O}$	1000MΩ	DC500V
	I/O Capacitance 隔离电容	TYP. 典型值	$C_{I/O}$	1.6pF	f=1MHz
		MAX. 最大值		2pF	

通讯地址: 陕西省西安市国家民用航天产业基地航天中路385号众创广场11层1101.1102.1104室

生产地址: 陕西省宝鸡市陈仓区群力路1号 邮政编码: 721300

电话: (0917)-6293969 18609177833

传 真: (0917)-6293969



# PhotoMOS 光 MOS 继电器 (SMD8/DIP8)

## Reference Data 参考数值 (BCW252A)

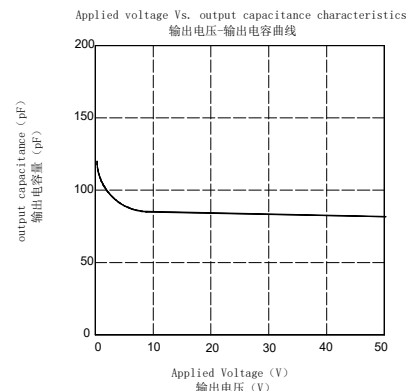
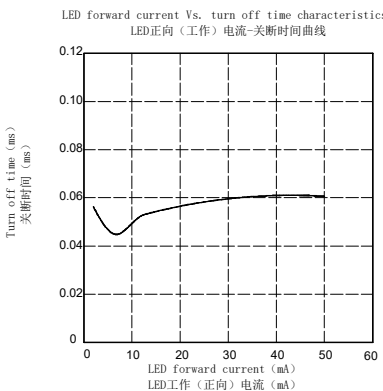
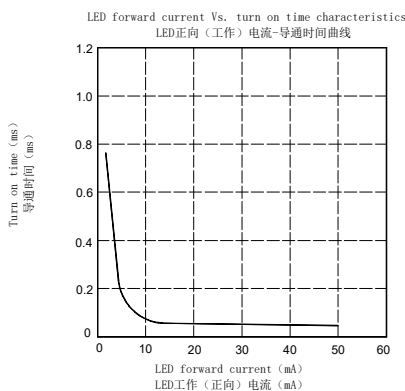
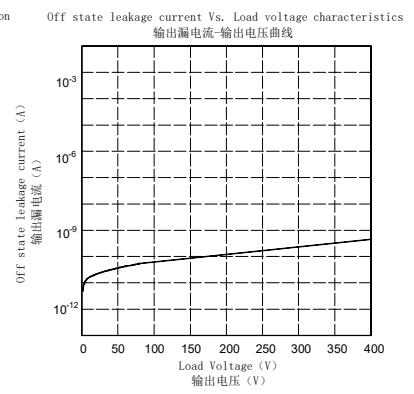
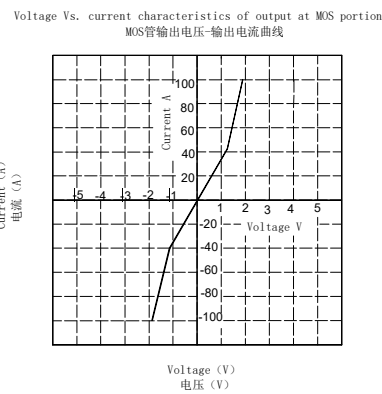
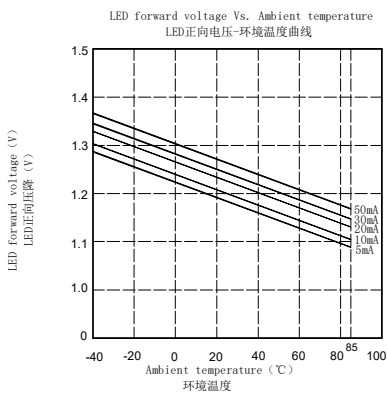
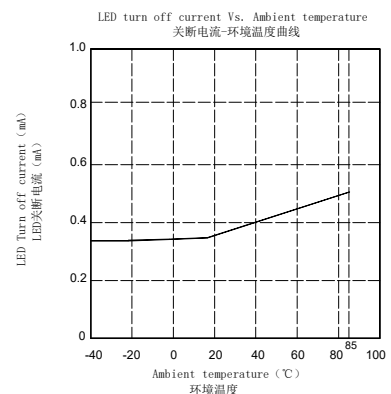
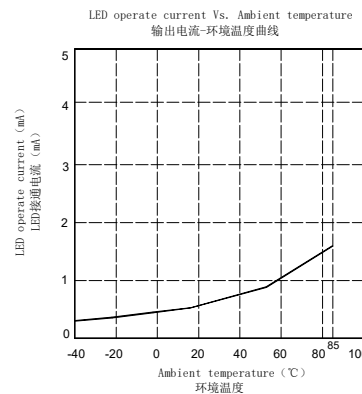
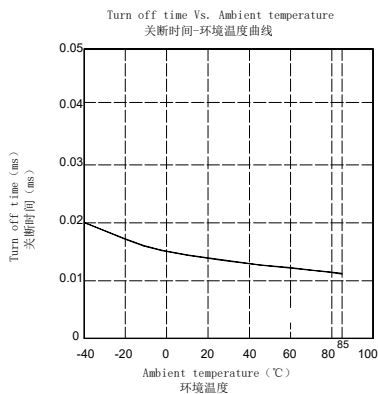
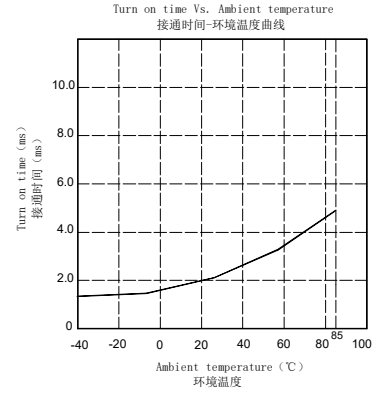
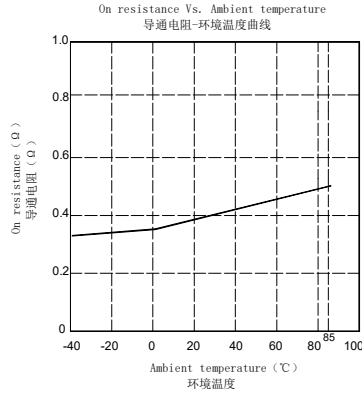
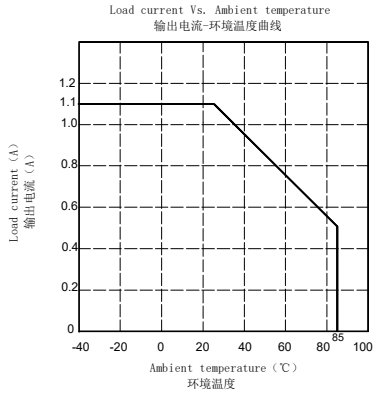

通讯地址: 陕西省西安市国家民用航天产业基地航天中路385号众创广场11层1101.1102.1104室

生产地址: 陕西省宝鸡市陈仓区群力路1号 邮政编码: 721300

电话: (0917)-6293969 18609177833

传 真: (0917)-6293969

## X-ON Electronics

Largest Supplier of Electrical and Electronic Components

*Click to view similar products for [Solid State Relays - PCB Mount](#) category:*

*Click to view products by [Vishay](#) manufacturer:*

Other Similar products are found below :

[M86F-2W](#) [M90F-2W](#) [M90F-2Y](#) [901-SX](#) [G2-1A07-ST](#) [G2-1A07-TT](#) [G2-1B02-TT](#) [G2-DA06-ST](#) [PLA134S](#) [DS11-1005](#) [AQH3213J](#)  
[AQV210EHJ](#) [AQV212J](#) [AQV252GAJ](#) [AQV258AJ](#) [AQY210ST](#) [AQY221N2SJ](#) [AQY221R2SJ](#) [EFR1200480A150](#) [901-7](#) [LCA220](#) [LCB110S](#)  
[1618400-5](#) [SR75-1ST](#) [AQV112KLJ](#) [AQV212AJ](#) [AQV238AD01](#) [AQV252GAXJ](#) [AQW414TS](#) [AQY212ST](#) [AQY275AXJ](#) [AQY414SXE01](#)  
[G2-1A02-ST](#) [G2-1A03-ST](#) [G2-1A03-TT](#) [G2-1A05-ST](#) [G2-1A06-TT](#) [G2-1A23-TT](#) [G2-1B01-ST](#) [G2-1B01-TT](#) [G2-1B02-ST](#) [G2-DA03-ST](#)  
[G2-DA03-TT](#) [G2-DA06-TT](#) [3-1617776-2](#) [CTA2425](#) [TLP3131\(F\)](#) [LBA110S](#) [LBB110S](#) [LCA110LSTR](#)