

## Monolithic Dual SPST CMOS Analog Switch

### DESCRIPTION

The DG200B is a dual, single-pole, single-throw analog switch designed to provide general purpose switching of analog signals. This device is ideally suited for designs requiring a wide analog voltage range coupled with low on-resistance.

The DG200B is designed on Vishay Siliconix' improved PLUS-40 CMOS process. An epitaxial layer prevents latchup.

Each switch conducts equally well in both directions when on, and blocks up to 30 V peak-to-peak when off. In the on condition, this bi-directional switch introduces no offset voltage of its own.

### FEATURES

- $\pm 15$  V Input Signal Range
- 44 V Maximum Supply Ranges
- On-Resistance:  $45 \Omega$
- TTL and CMOS Compatibility



**RoHS\***  
COMPLIANT

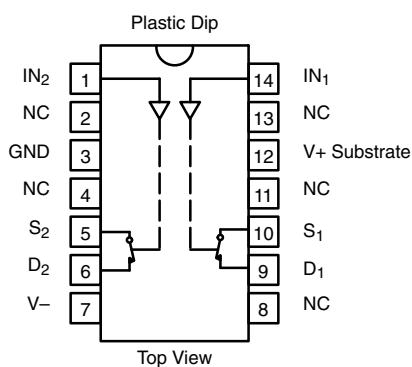
### BENEFITS

- Wide Dynamic Range
- Simple Interfacing
- Reduced External Component Count

### APPLICATIONS

- Servo Control Switching
- Programmable Gain Amplifiers
- Audio Switching
- Programmable Filters

### FUNCTIONAL BLOCK DIAGRAM AND PIN CONFIGURATION



### TRUTH TABLE

Logic	Switch
0	ON
1	OFF

Logic "0"  $\leq 0.8$  V  
Logic "1"  $\geq 2.4$  V

### ORDERING INFORMATION

Temp Range	Package	Part Number
- 40 to 85 °C	14-Pin Plastic DIP	DG200BDJ DG200BDJ-E3

\* Pb containing terminations are not RoHS compliant, exemptions may apply

<b>ABSOLUTE MAXIMUM RATINGS</b> $T_A = 25^\circ\text{C}$ , unless otherwise noted			
Parameter		Limit	Unit
V+ to V-		44	V
GND to V-		25	
Digital Inputs <sup>a</sup> , V <sub>S</sub> , V <sub>D</sub>		(V-) - 2 V to (V+) + 2 V or 30 mA, whichever occurs first	
Current (Any Terminal) Continuous		30	mA
Current S or D	(Pulsed at 1 ms, 10 % Duty Cycle Max)	100	
Storage Temperature		- 65 to 150	°C
Power Dissipation (Package) <sup>b</sup>	14-Pin Plastic DIP <sup>c</sup>	470	mW

Notes:

- a. Signals on S<sub>x</sub>, D<sub>x</sub>, or IN<sub>x</sub> exceeding V+ or V- will be clamped by internal diodes. Limit forward diode current to maximum current ratings.
- b. All leads welded or soldered to PC Board.
- c. Derate 6.5 mW/°C above 25 °C.

**SCHEMATIC DIAGRAM (TYPICAL CHANNEL)**

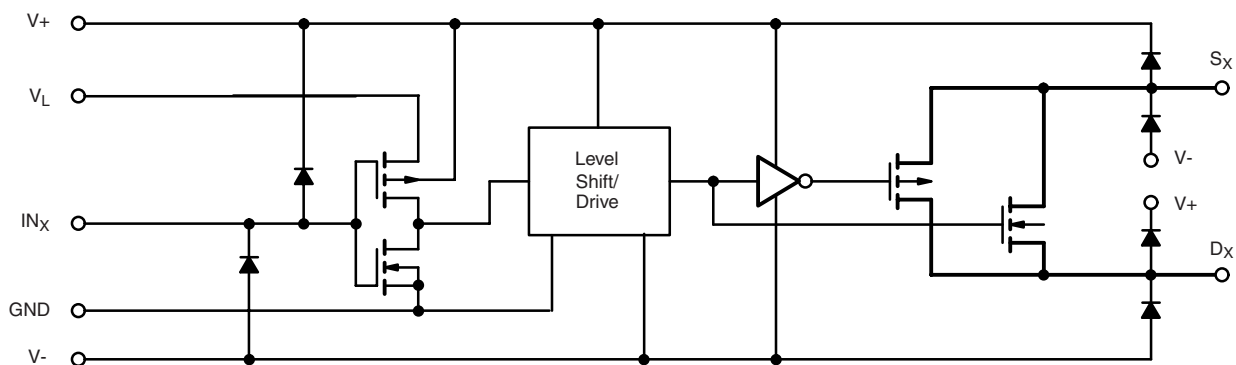


Figure 1.



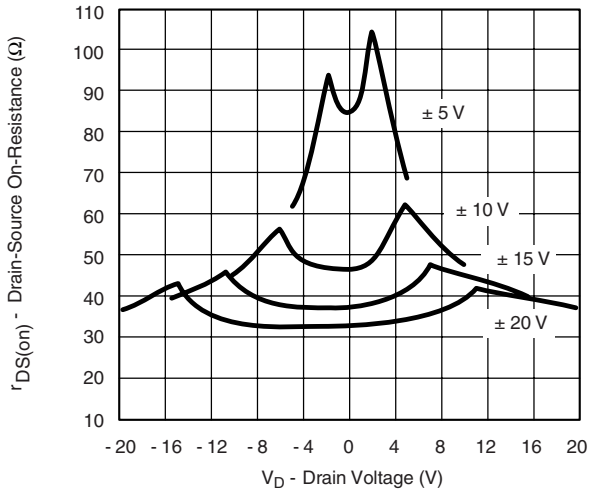
SPECIFICATIONS <sup>a</sup>							
Parameter	Symbol	Test Conditions Unless Otherwise Specified V <sub>+</sub> = 15 V, V <sub>-</sub> = - 15 V V <sub>IN</sub> = 2.4 V, 0.8 V <sup>f</sup>	Temp <sup>b</sup>	Limits - 40 to 85 °C			Unit
				Min <sup>c</sup>	Typ <sup>d</sup>	Max <sup>c</sup>	
<b>Analog Switch</b>							
Analog Signal Range <sup>e</sup>	V <sub>ANALOG</sub>		Full	- 15		15	V
Drain-Source On-Resistance	r <sub>DS(on)</sub>	V <sub>D</sub> = ± 10 V, I <sub>S</sub> = - 1 mA	Room Full		45	85 100	Ω
Source Off Leakage Current	I <sub>S(off)</sub>	V <sub>S</sub> = ± 14 V, V <sub>D</sub> = ∓ 14 V	Room Full	- 2 - 100	± 0.01	2 100	nA
Drain Off Leakage Current	I <sub>D(off)</sub>	V <sub>D</sub> = ± 14 V, V <sub>S</sub> = ∓ 14 V	Room Full	- 2 - 100	± 0.01	2 100	
Channel On Leakage Current <sup>f</sup>	I <sub>D(on)</sub>	V <sub>S</sub> = V <sub>D</sub> = ± 14 V	Room Full	- 2 - 200	± 0.1	2 200	
<b>Digital Control</b>							
Input Current with Input Voltage High	I <sub>INH</sub>	V <sub>IN</sub> = 2.4 V	Room Full	- 0.5 - 1	0.0009		μA
		V <sub>IN</sub> = 15 V	Room Full		0.005	0.5 1	
Input Current with Input Voltage Low	I <sub>INL</sub>	V <sub>IN</sub> = 0 V	Room Full	- 0.5 - 1	- 0.0015		
<b>Dynamic Characteristics</b>							
Turn-On Time	t <sub>ON</sub>	See Switching Time Test Circuit	Room		300	1000	ns
Turn-Off Time	t <sub>OFF</sub>		Room		200	425	
Charge Injection	Q	C <sub>L</sub> = 1000 pF, R <sub>G</sub> = 0 Ω, V <sub>G</sub> = 0 V	Room		1		pC
Source Off Capacitance	C <sub>S(off)</sub>	f = 140 kHz V <sub>IN</sub> = 5 V	Room		5		pF
Drain Off Capacitance	C <sub>D(off)</sub>		V <sub>D</sub> = 0 V	Room		5	
Channel-On Capacitance	C <sub>D(on)</sub> + C <sub>S(on)</sub>	V <sub>S</sub> = V <sub>D</sub> = 0 V, V <sub>IN</sub> = 0 V	Room		16		
Off Isolation	OIRR	V <sub>IN</sub> = 5 V, R <sub>L</sub> = 75 Ω V <sub>S</sub> = 2 V, f = 1 MHz	Room		90		dB
Crosstalk (Channel-to-Channel)	X <sub>TALK</sub>		Room		95		
<b>Power Supplies</b>							
Positive Supply Current	I <sub>+</sub>	Both Channels On or Off V <sub>IN</sub> = 0 V and 5.0 V	Room			50	μA
Negative Supply Current	I <sub>-</sub>		Room		- 10		

Notes:

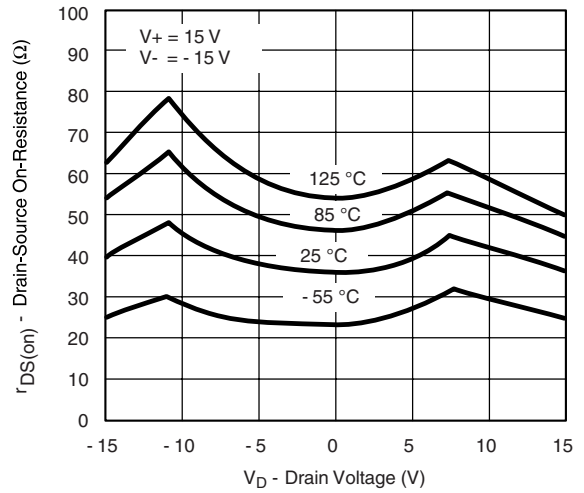
- a. Refer to PROCESS OPTION FLOWCHART.
- b. Room = 25 °C, Full = as determined by the operating temperature suffix.
- c. Typical values are for DESIGN AID ONLY, not guaranteed nor subject to production testing.
- d. The algebraic convention whereby the most negative value is a minimum and the most positive a maximum, is used in this data sheet.
- e. Guaranteed by design, not subject to production test.
- f. V<sub>IN</sub> = input voltage to perform proper function.

*Stresses beyond those listed under "Absolute Maximum Ratings" may cause permanent damage to the device. These are stress ratings only, and functional operation of the device at these or any other conditions beyond those indicated in the operational sections of the specifications is not implied. Exposure to absolute maximum rating conditions for extended periods may affect device reliability.*

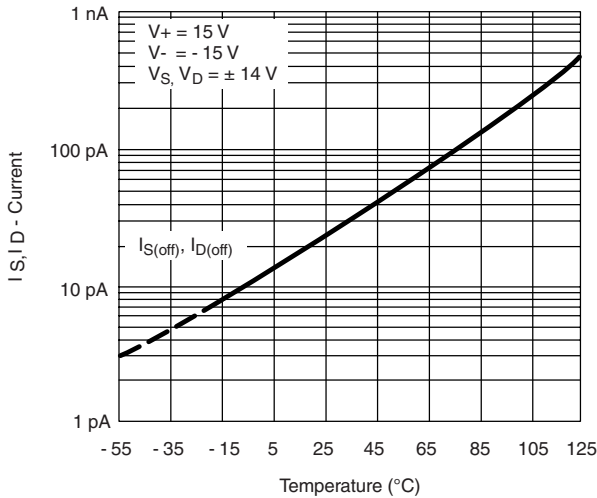
**TYPICAL CHARACTERISTICS** 25 °C, unless otherwise noted



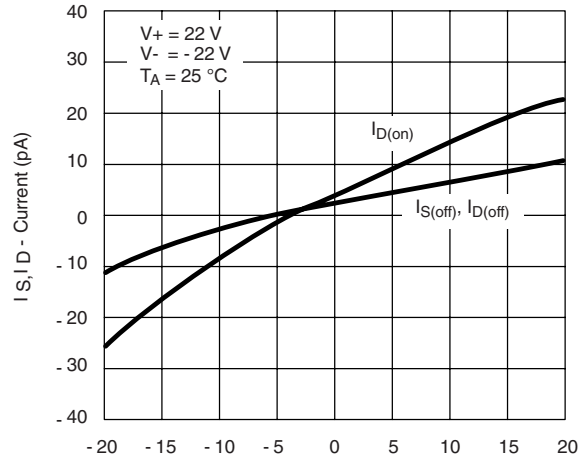
**$r_{DS(on)}$  vs.  $V_D$  and Power Supply Voltages**



**$r_{DS(on)}$  vs.  $V_D$  and Temperature**



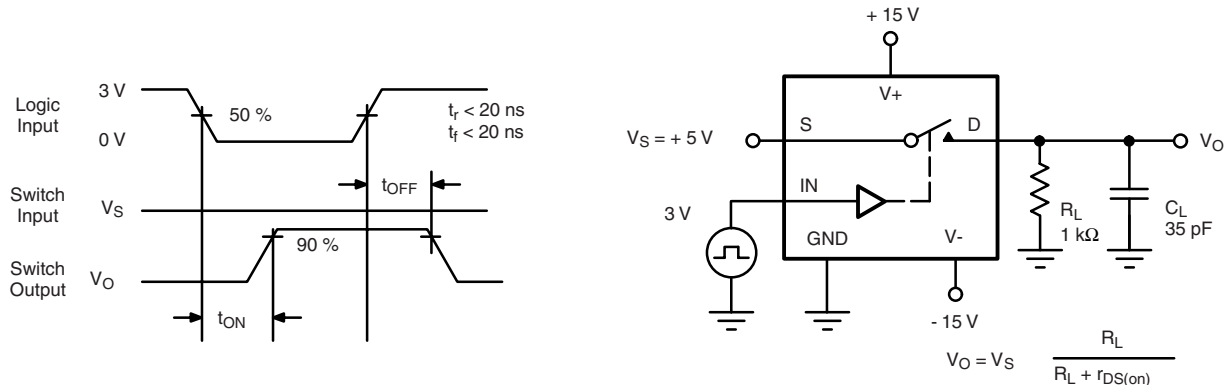
**Leakage Current vs. Temperature**



**Leakage Currents vs. Analog Voltage**

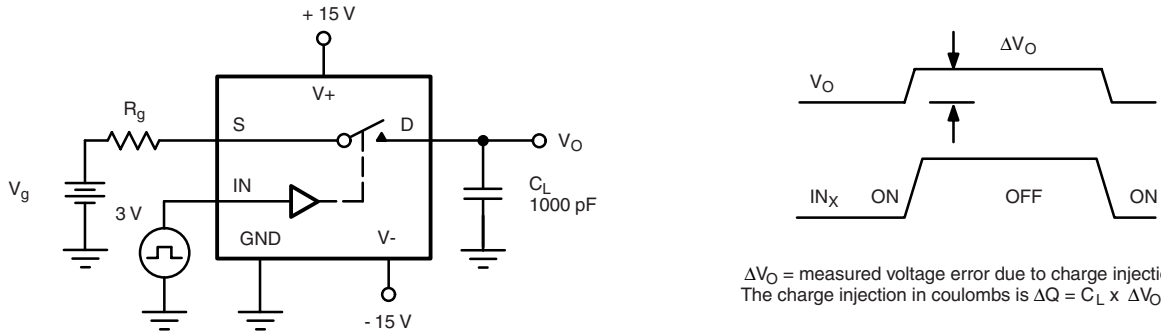
**TEST CIRCUITS**

$V_O$  is the steady state output with switch on. Feedthrough via gate capacitance may result in spikes at leading and trailing edge of output waveform.

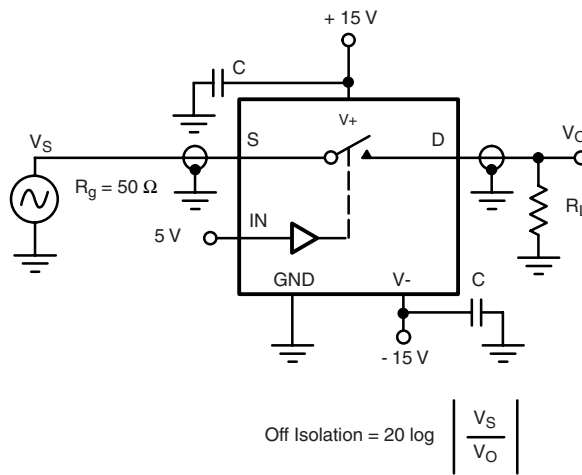


**Figure 2. Switching Time**

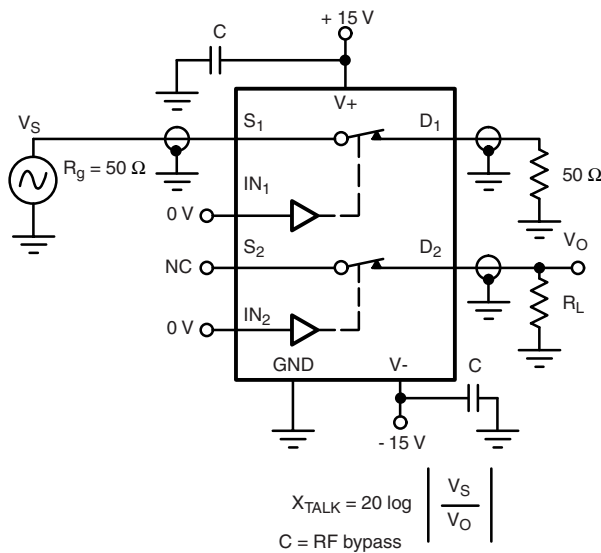
**TEST CIRCUITS**



**Figure 3. Charge Injection**



**Figure 4. Off Isolation**



**Figure 5. Channel-to-Channel Crosstalk**

Vishay Siliconix maintains worldwide manufacturing capability. Products may be manufactured at one of several qualified locations. Reliability data for Silicon Technology and Package Reliability represent a composite of all qualified locations. For related documents such as package/tape drawings, part marking, and reliability data, see <http://www.vishay.com/ppg?71357>.



## Disclaimer

All product specifications and data are subject to change without notice.

Vishay Intertechnology, Inc., its affiliates, agents, and employees, and all persons acting on its or their behalf (collectively, "Vishay"), disclaim any and all liability for any errors, inaccuracies or incompleteness contained herein or in any other disclosure relating to any product.

Vishay disclaims any and all liability arising out of the use or application of any product described herein or of any information provided herein to the maximum extent permitted by law. The product specifications do not expand or otherwise modify Vishay's terms and conditions of purchase, including but not limited to the warranty expressed therein, which apply to these products.

No license, express or implied, by estoppel or otherwise, to any intellectual property rights is granted by this document or by any conduct of Vishay.

The products shown herein are not designed for use in medical, life-saving, or life-sustaining applications unless otherwise expressly indicated. Customers using or selling Vishay products not expressly indicated for use in such applications do so entirely at their own risk and agree to fully indemnify Vishay for any damages arising or resulting from such use or sale. Please contact authorized Vishay personnel to obtain written terms and conditions regarding products designed for such applications.

Product names and markings noted herein may be trademarks of their respective owners.

## X-ON Electronics

Largest Supplier of Electrical and Electronic Components

*Click to view similar products for [Analogue Switch ICs category](#):*

*Click to view products by [Vishay manufacturer](#):*

Other Similar products are found below :

[FSA3051TMX](#) [NLAS4684FCTCG](#) [NLAS5223BLMNR2G](#) [NLX2G66DMUTCG](#) [425541DB](#) [425528R](#) [099044FB](#) [NLAS5123MNR2G](#)  
[PI5A4157CEX](#) [PI5A4599BCEX](#) [NLAS4717EPFCT1G](#) [PI5A3167CCEX](#) [SLAS3158MNR2G](#) [PI5A392AQE](#) [PI5A4157ZUEX](#)  
[PI5A3166TAEX](#) [FSA634UCX](#) [TC4066BP\(N,F\)](#) [DG302BDJ-E3](#) [PI5A100QEX](#) [HV2605FG-G](#) [HV2301FG-G](#) [RS2117YUTQK10](#)  
[RS2118YUTQK10](#) [RS2227XUTQK10](#) [ADG452BRZ-REEL7](#) [MAX4066ESD+](#) [MAX391CPE+](#) [MAX4730EXT+T](#) [MAX314CPE+](#)  
[BU4066BCFV-E2](#) [MAX313CPE+](#) [BU4S66G2-TR](#) [NLASB3157MTR2G](#) [TS3A4751PWR](#) [NLAST4599DFT2G](#) [NLAST4599DTT1G](#)  
[DG300BDJ-E3](#) [DG2503DB-T2-GE1](#) [TC4W53FU\(TE12L,F\)](#) [74HC2G66DC.125](#) [ADG619BRMZ-REEL](#) [ADG1611BRUZ-REEL7](#)  
[DG2535EDQ-T1-GE3](#) [LTC201ACN#PBF](#) [74LV4066DB,118](#) [ISL43410IUZ](#) [FSA2275AUMX](#) [DIO1500WL12](#) [ADG742BKSZ-REEL7](#)