

Low-Voltage, 0.8 Ω R_{ON} , Dual SPST Analog Switch

DESCRIPTION

The DG2741, DG2742, DG2743 are low voltage, single supply, dual SPST analog switches. Designed for high performance switching of analog signals, the DG2741, DG2742, DG2743 provide low on-resistance (0.8 Ω at + 2.7 V), fast speed (t_{ON} , t_{OFF} at 35 ns and 33 ns) and the ability to handle signals over the entire analog voltage range.

When operated on a + 3 V supply, control pins are compatible with 1.8 V digital logic. Additionally, on-resistance flatness and matching (0.18 Ω and 0.08 Ω , respectively) offer high accuracy between channels.

The DG2741 contains two normally open (NO) switches, the DG2742 contains two normally closed (NC) switches, and the DG2743 contains one normally open and one normally closed switch. Break-before-make is guaranteed.

Built on Vishay Siliconix's low voltage submicron CMOS process, the DG2741, DG2742, DG2743 were designed to offer solutions that extend beyond audio/video functions, to providing the performance required for today's demanding mixed-signal switching in portable applications.

FEATURES

- Low voltage operation (1.6 V to 3.6 V)
- Low on-resistance - $R_{DS(on)}$: 0.8 Ω at 2.7 V
- High current handling capacity: 150 mA continuous
- Off-isolation: - 56 dB at 1 MHz
- Fast switching: 25 ns t_{ON}
- Low charge injection - Q_{INJ} : 5.8 pC
- Low power consumption: < 1 μ W
- ESD protection > 2 000 V

BENEFITS

- High accuracy
- High bandwidth
- TTL and low voltage logic compatibility
- Low power consumption
- Reduced PCB space (SOT23-8 and MSOP-8)

APPLICATIONS

- Mixed signal routing
- Portable and battery operated systems
- Low voltage data acquisition
- Modems
- PCMCIA cards

FUNCTIONAL BLOCK DIAGRAM AND PIN CONFIGURATION (DG2741)

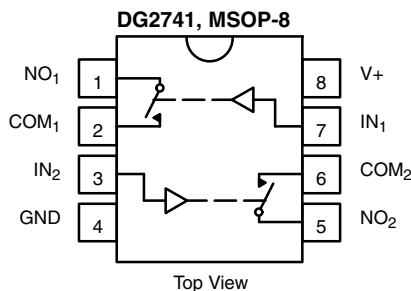

Device Marking: 2741

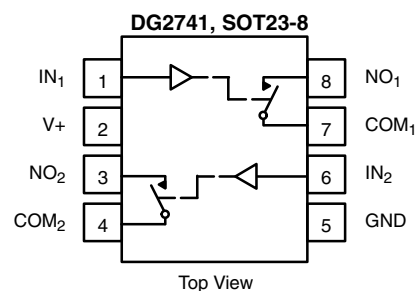

Device Marking: F3

TRUTH TABLE (DG2741)

Logic	Switch
0	Off
1	On

FUNCTIONAL BLOCK DIAGRAM AND PIN CONFIGURATION (DG2742, DG2743)

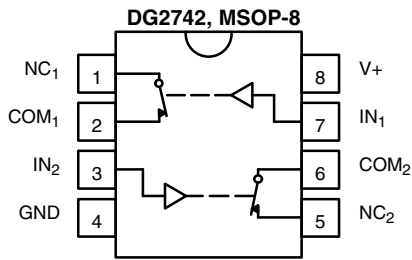

Top View

Device Marking: 2742

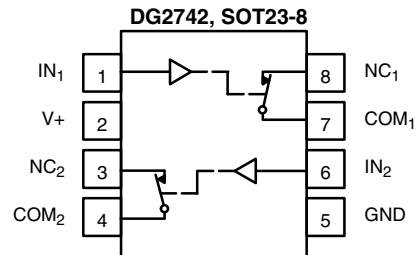

Top View

Device Marking: F4

TRUTH TABLE (DG2742)	
Logic	Switch
0	On
1	Off

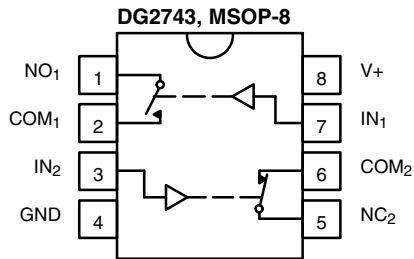

Top View

Device Marking: 2743

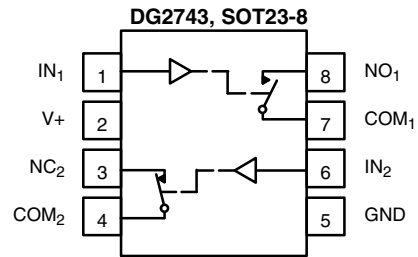

Top View

Device Marking: F5

TRUTH TABLE (DG2743)		
Logic	Switch-1	Switch-2
0	Off	On
1	On	Off

ORDERING INFORMATION		
Temp. Range	Package	Part Number
- 40 °C to 85 °C	MSOP-8	DG2741DQ-T1
		DG2742DQ-T1
		DG2743DQ-T1
	SOT23-8	DG2741DS-T1
		DG2742DS-T1
		DG2743DS-T1



ABSOLUTE MAXIMUM RATINGS ($T_A = 25\text{ }^\circ\text{C}$, unless otherwise noted)			
Parameter	Limit	Unit	
Referenced V_+ to GND	- 0.3 to + 4 V	V	
IN, COM, NC, NO ^a	- 0.3 V to ($V_+ + 0.3\text{ V}$)		
Continuous Current (NO, NC and COM Pins)	± 200	mA	
Peak Current (Pulsed at 1 ms, 10 % duty cycle)	± 300		
ESD per Method 3015.7	> 2	kV	
Storage Temperature (D Suffix)	- 65 to 150	$^\circ\text{C}$	
Power Dissipation (Packages) ^c	6-Pin SC-70 ^c	250	mW

Notes:

- a. Signals on NC, NO, or COM or IN exceeding V_+ will be clamped by internal diodes. Limit forward diode current to maximum current ratings.
- b. All leads welded or soldered to PC board.
- c. Derate 3.1 mW/ $^\circ\text{C}$ above 70 $^\circ\text{C}$.

SPECIFICATIONS ($V_+ = 1.8\text{ V}$)							
Parameter	Symbol	Test Conditions Otherwise Unless Specified $V_+ = 1.8\text{ V}$, $\pm 10\%$, $V_{IN} = 0.4$ or 1.0 V^e	Temp. ^a	Limits - 40 $^\circ\text{C}$ to 85 $^\circ\text{C}$			Unit
				Min. ^b	Typ. ^c	Max. ^b	
Analog Switch							
Analog Signal Range ^d	V_{NO}, V_{NC} V_{COM}		Full	0		V_+	V
On-Resistance	R_{ON}	$V_+ = 1.8\text{ V}$, $V_{COM} = 0.9\text{ V}$ $I_{NO}, I_{NC} = 10\text{ mA}$	Room Full ^d		0.9	2.5 4.0	Ω
R_{ON} Flatness ^d	R_{ON} Flatness	$V_+ = 1.8\text{ V}$, $V_{COM} = 0$ to V_+ , $I_{NO}, I_{NC} = 10\text{ mA}$	Room		0.25		
R_{ON} Match ^d	ΔR_{ON}		Room		0.05		
Switch Off Leakage Current ^f	$I_{NO(off)}$ $I_{NC(off)}$	$V_+ = 1.8\text{ V}$ $V_{NO}, V_{NC} = 0.2\text{ V}/2.0\text{ V}$, $V_{COM} = 1.5\text{ V}/0.3\text{ V}$	Room Full ^d	- 1 - 10		1 10	nA
	$I_{COM(off)}$		Room Full ^d	- 1 - 10		1 10	
Channel-On Leakage Current ^f	$I_{COM(on)}$	$V_+ = 1.8\text{ V}$, $V_{NO}, V_{NC} = V_{COM} = 0.3\text{ V}/1.5\text{ V}$	Room Full ^d	- 1 - 10		1 10	
Digital Control							
Input High Voltage	V_{INH}		Full	1.0			V
Input Low Voltage	V_{INL}		Full			0.4	
Input Capacitance ^d	C_{in}		Full		5.5		pF
Input Current ^f	I_{INL} or I_{INH}	$V_{IN} = 0$ or V_+	Full	- 1		1	μA
Dynamic Characteristics							
Turn-On Time ^d	t_{ON}	V_{NO} or $V_{NC} = 1.5\text{ V}$, $R_L = 50\text{ }\Omega$, $C_L = 35\text{ pF}$ figures 1 and 2	Room Full ^d		33	45 50	ns
Turn-Off Time ^d	t_{OFF}		Room Full ^d		27	40 45	
Break-Before-Make Time ^d	t_d		Room	3			
Charge Injection ^d	Q_{INJ}	$C_L = 1\text{ nF}$, $V_{GEN} = 0\text{ V}$, $R_{GEN} = 0\text{ }\Omega$, figure 3	Room		20		pC
Off-Isolation ^d	OIRR	$R_L = 1\text{ k}\Omega$, $C_L = 5\text{ pF}$, $f = 1\text{ MHz}$	Room		55		dB
Crosstalk ^d	X_{TALK}		Room		91		
NO, NC Off Capacitance ^d	$C_{NO(off)}$ $C_{NC(off)}$	$V_{IN} = 0$ or V_+ , $f = 1\text{ MHz}$	Room		88		pF
Channel-On Capacitance ^d	C_{ON}		Room		105		

SPECIFICATIONS (V ₊ = 3.0 V)							
Parameter	Symbol	Test Conditions Otherwise Unless Specified V ₊ = 3 V, ± 10 %, V _{IN} = 0.5 or 1.4 V ^e	Temp. ^a	Limits - 40 °C to 85 °C			Unit
				Min. ^b	Typ. ^c	Max. ^b	
Analog Switch							
Analog Signal Range ^d	V _{NO} , V _{NC} V _{COM}		Full	0		V ₊	V
On-Resistance	R _{ON}	V ₊ = 2.7 V, V _{COM} = 0.2 V/1.5 V, I _{NO} I _{NC} = 100 mA	Room Full		0.4	0.8 0.9	Ω
R _{ON} Flatness	R _{ON} Flatness	V ₊ = 2.7 V, V _{COM} = 1.5, 2 V, I _{NO} , I _{NC} = 100 mA	Room		0.8	0.18	
R _{ON} MatchFlat	ΔR _{ON}		Room		0.05	0.08	
Switch Off Leakage Current	I _{NO(off)} I _{NC(off)}	V ₊ = 3.3 V V _{NO} , V _{NC} = 0.3 V/3 V, V _{COM} = 3 V/0.3 V	Room Full	- 1 - 10		1 10	nA
	I _{COM(off)}		Room Full	- 1 - 10		1 10	
Channel-On Leakage Current	I _{COM(on)}	V ₊ = 3.3 V, V _{NO} , V _{NC} = V _{COM} = 0.3 V/3 V	Room Full	- 1 - 10		1 10	
Digital Control							
Input High Voltage	V _{INH}		Full	1.4			V
Input Low Voltage	V _{INL}		Full			0.5	
Input Capacitance ^d	C _{in}		Full		5.5		pF
Input Current ^f	I _{INL} or I _{INH}	V _{IN} = 0 or V ₊	Full	- 1		1	μA
Dynamic Characteristics							
Turn-On Time	t _{ON}	V _{NO} or V _{NC} = 1.5 V, R _L = 50 Ω, C _L = 35 pF V ₊ = 2.7 V, figures 1 and 2	Room Full		20	30 35	ns
Turn-Off Time	t _{OFF}		Room Full		18	28 33	
Break-Before-Make Time	t _d		Room	1			
Charge Injection ^d	Q _{INJ}	C _L = 1 nF, V _{GEN} = 0 V, R _{GEN} = 0 Ω, figure 3	Room		5.8		pC
Off-Isolation ^d	OIRR	R _L = 1 kΩ, C _L = 5 pF, f = 1 MHz	Room		- 56		dB
Crosstalk ^d	X _{TALK}		Room		- 89		
NO, NC Off Capacitance ^d	C _{NO(off)} C _{NC(off)}	V ₊ = 3.6 V, V _{IN} = 0 or V ₊ , f = 1 MHz	Room		81		pF
Channel-On Capacitance ^d	C _{ON}		Room		103		
Power Supply							
Power Supply Range	V ₊			1.5		3.6	V
Power Supply Current	I ₊	V ₊ = 3.6 V, V _{IN} = 0 or V ₊			0.01	1.0	μA

Notes:

- a. Room = 25 °C, Full = as determined by the operating suffix.
- b. The algebraic convention whereby the most negative value is a minimum and the most positive a maximum, is used in this data sheet.
- c. Typical values are for design aid only, not guaranteed nor subject to production testing.
- d. Guarantee by design, nor subjected to production test.
- e. V_{IN} = input voltage to perform proper function.
- f. Guaranteed by 3 V leakage testing, not production tested.

Stresses beyond those listed under "Absolute Maximum Ratings" may cause permanent damage to the device. These are stress ratings only, and functional operation of the device at these or any other conditions beyond those indicated in the operational sections of the specifications is not implied. Exposure to absolute maximum rating conditions for extended periods may affect device reliability.

TYPICAL CHARACTERISTICS (25 °C, unless otherwise noted)

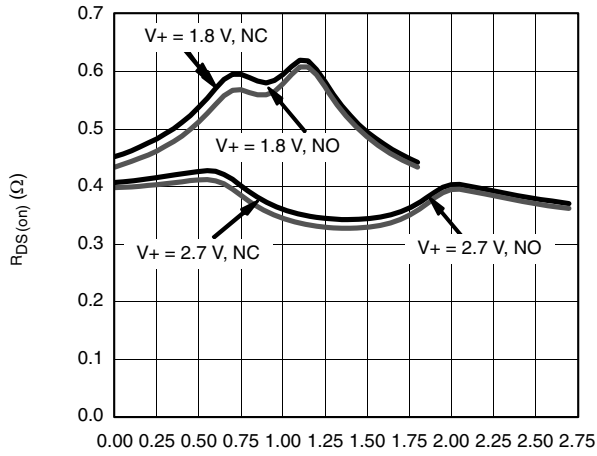

$R_{DS(on)}$ vs. V_{COM} vs. 1 V_{CC}

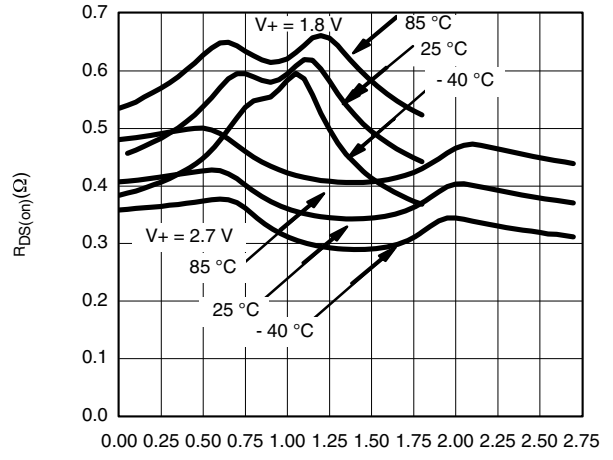

$R_{DS(on)}$ vs. V_D , V_{CC} and Temperature

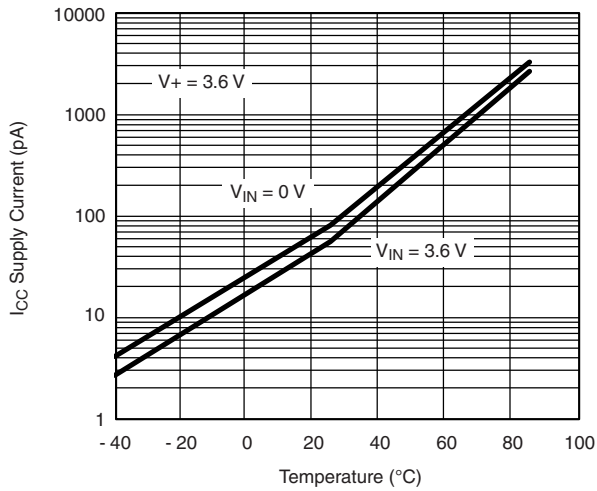

Supply Current vs. Temperature

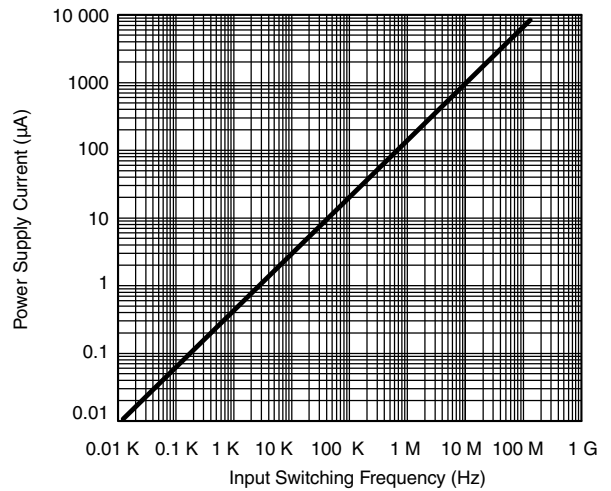

Switching Frequency vs. Supply Current

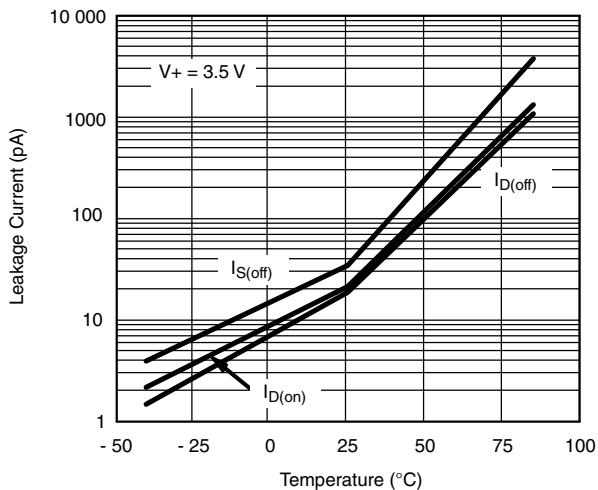

Leakage Current vs. Temperature

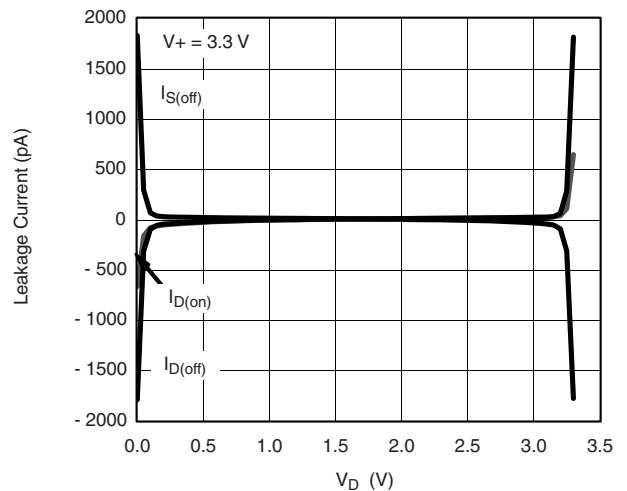

Leakage Current vs. Analog Voltage

TYPICAL CHARACTERISTICS (25 °C, unless otherwise noted)

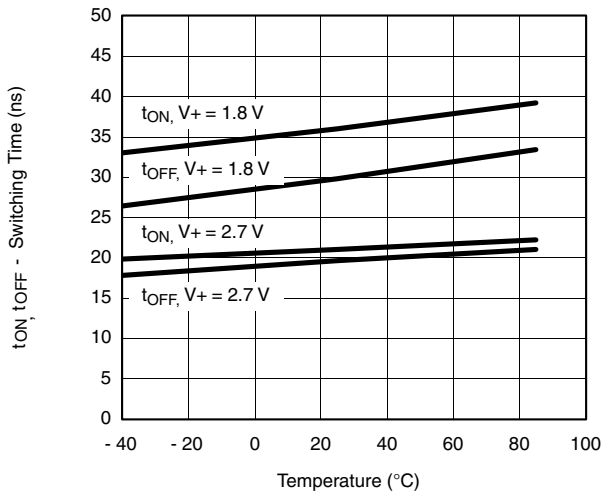

Switching Time vs. V_{CC} and Temperature

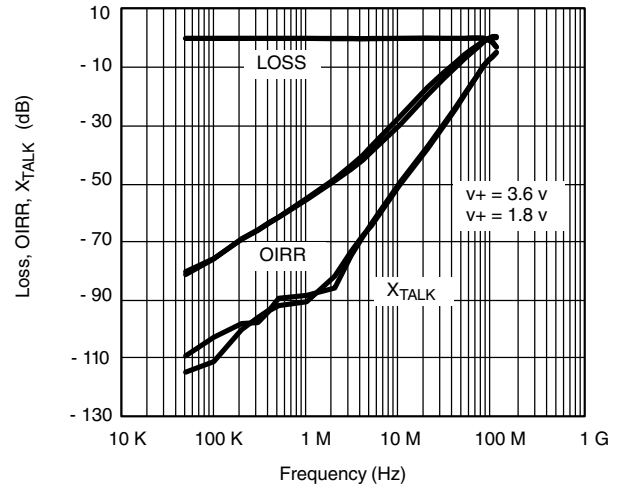

Insertion Loss, Off-Isolation Crosstalk vs. Frequency

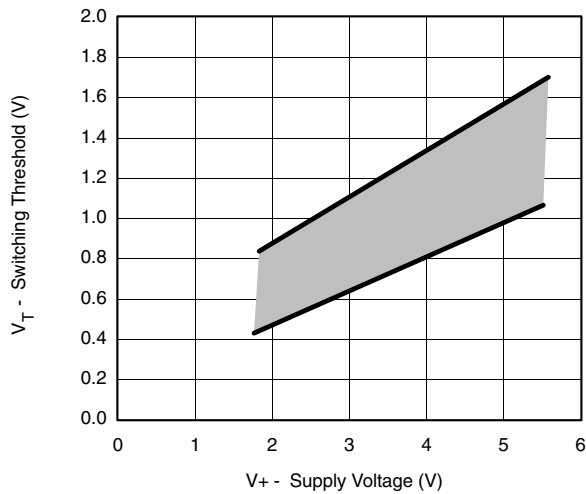

Switching Threshold vs. Supply Voltage

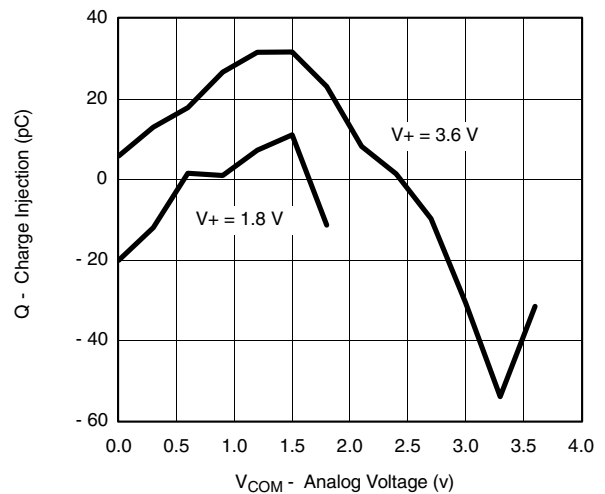

Charge Injection vs. Analog Voltage

TEST CIRCUITS

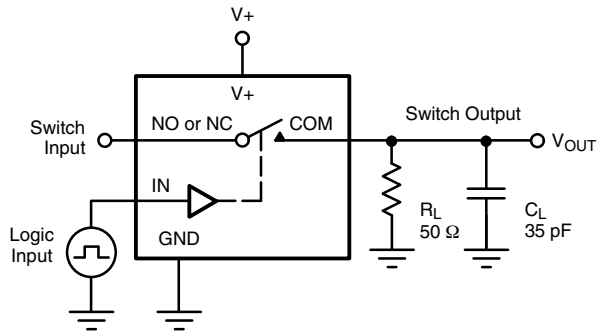

C_L (includes fixture and stray capacitance)

$$V_{OUT} = V_{COM} \left(\frac{R_L}{R_L + R_{ON}} \right)$$

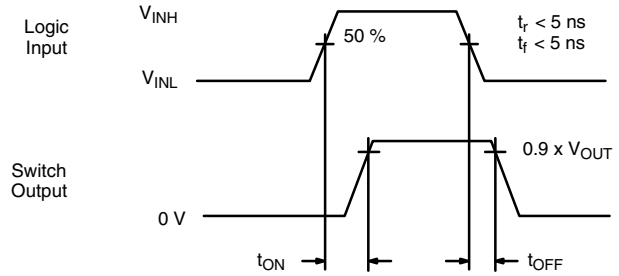

Logic "1" = Switch On
 Logic input waveforms inverted for switches that have the opposite logic sense.

Figure 1. Switching Time

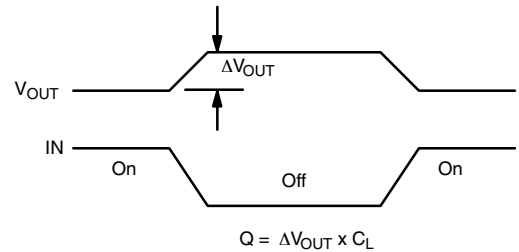
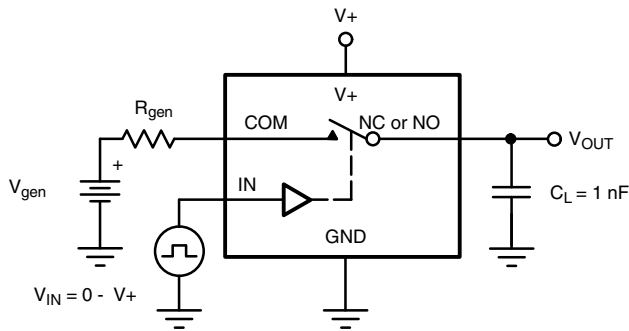

IN depends on switch configuration: input polarity determined by sense of switch.

Figure 2. Charge Injection

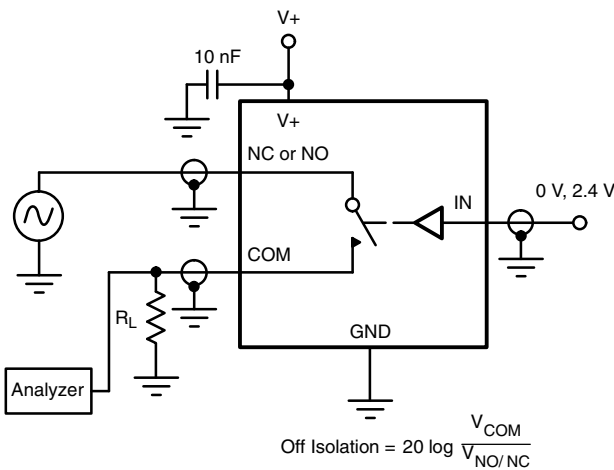

Figure 3. Off-Isolation

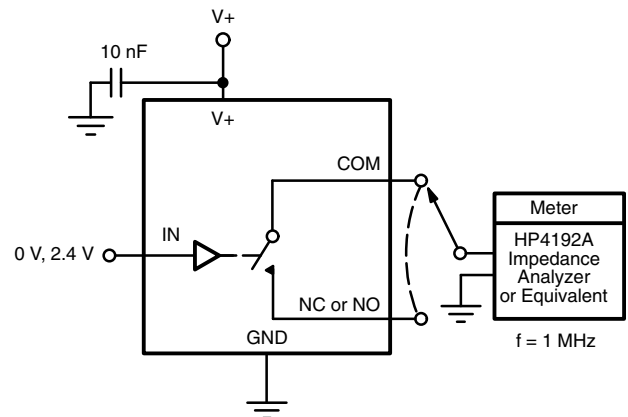

Figure 4. Channel Off/On Capacitance

Vishay Siliconix maintains worldwide manufacturing capability. Products may be manufactured at one of several qualified locations. Reliability data for Silicon Technology and Package Reliability represent a composite of all qualified locations. For related documents such as package/tape drawings, part marking, and reliability data, see www.vishay.com/ppg?72708.



MSOP: 8-LEADS

JEDEC Part Number: MO-187, (Variation AA and BA)

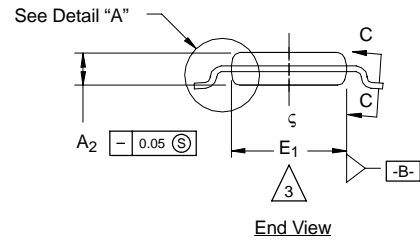
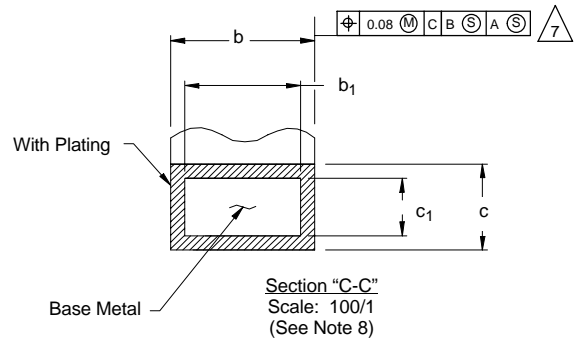
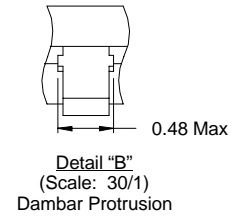
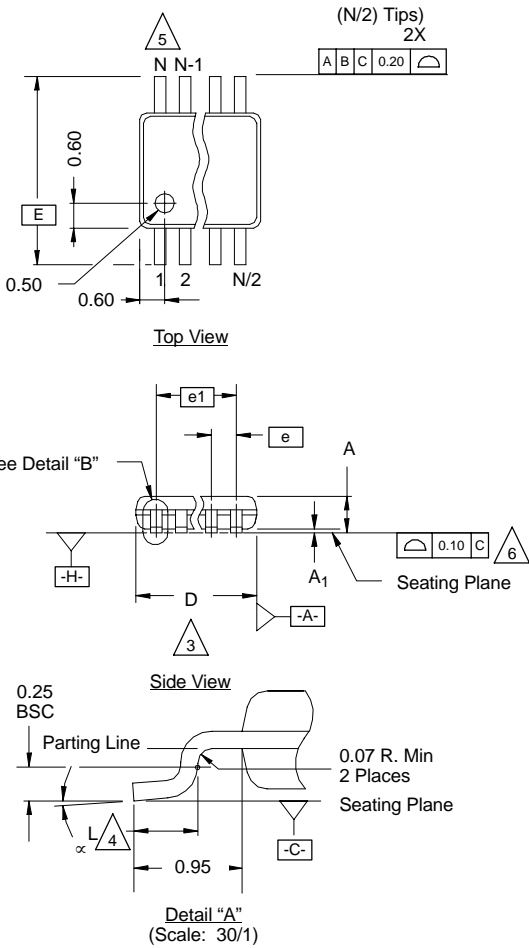

NOTES:

1. Die thickness allowable is 0.203 ± 0.0127 .
2. Dimensioning and tolerances per ANSI.Y14.5M-1994.
3. Dimensions "D" and "E₁" do not include mold flash or protrusions, and are measured at Datum plane [-H-], mold flash or protrusions shall not exceed 0.15 mm per side.
4. Dimension is the length of terminal for soldering to a substrate.
5. Terminal positions are shown for reference only.
6. Formed leads shall be planar with respect to one another within 0.10 mm at seating plane.
7. The lead width dimension does not include Dambar protrusion. Allowable Dambar protrusion shall be 0.08 mm total in excess of the lead width dimension at maximum material condition. Dambar cannot be located on the lower radius or the lead foot. Minimum space between protrusions and an adjacent lead to be 0.14 mm. See detail "B" and Section "C-C".
8. Section "C-C" to be determined at 0.10 mm to 0.25 mm from the lead tip.
9. Controlling dimension: millimeters.
10. This part is compliant with JEDEC registration MO-187, variation AA and BA.
11. Datums [-A-] and [-B-] to be determined Datum plane [-H-].
12. Exposed pad area in bottom side is the same as teh leadframe pad size.

N = 8L

Dim	MILLIMETERS			Note
	Min	Nom	Max	
A	-	-	1.10	
A ₁	0.05	0.10	0.15	
A ₂	0.75	0.85	0.95	
b	0.25	-	0.38	8
b ₁	0.25	0.30	0.33	8
c	0.13	-	0.23	
c ₁	0.13	0.15	0.18	
D	3.00 BSC			3
E	4.90 BSC			
E ₁	2.90	3.00	3.10	3
e	0.65 BSC			
e ₁	1.95 BSC			
L	0.40	0.55	0.70	4
N	8			5
α	0°	4°	6°	

ECN: T-02080—Rev. C, 15-Jul-02
DWG: 5867

SOT-23 : 8-LEAD

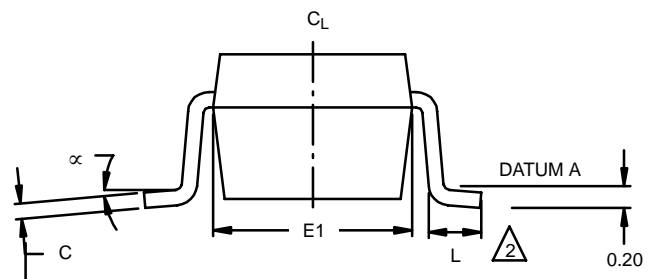
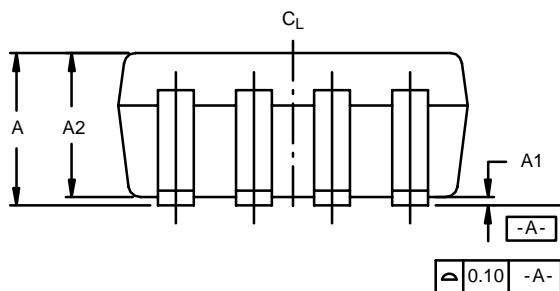
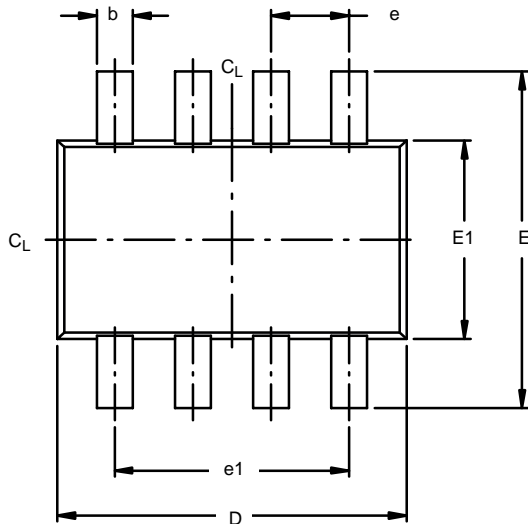

NOTES:

1. All dimensions are in millimeters.
2. Foot length measured at intercept point between Datum A and lead surface.
3. Package outline exclusive of mold flash and metal burr.
4. Package outline inclusive of solder plating.
5. No molding flash allowed on the top and bottom lead surface.

Dim	MILLIMETERS			INCHES		
	Min	Nom	Max	Min	Nom	Max
A	0.90	1.27	1.45	0.035	0.05	0.057
A1	0.00	0.0762	0.15	0.000	0.003	0.006
A2	0.90	1.20	1.30	0.035	0.047	0.051
b	0.22	0.30	0.38	0.009	0.012	0.015
C	0.09	0.152	0.20	0.004	0.006	0.008
D	2.80	2.9	3.00	0.11	0.114	0.118
E	2.60	2.8	23.00	0.102	0.11	0.118
E1	1.50	1.65	1.75	0.059	0.065	0.069
e	0.65 REF			0.026 REF		
e1	1.95 REF			0.077 REF		
L	0.35	0.45	0.55	0.014	0.018	0.022
α	0°	4°	8°	0°	4°	8°

ECN: C-03085—Rev. A, 07-Apr-03
DWG: 5895



Disclaimer

ALL PRODUCT, PRODUCT SPECIFICATIONS AND DATA ARE SUBJECT TO CHANGE WITHOUT NOTICE TO IMPROVE RELIABILITY, FUNCTION OR DESIGN OR OTHERWISE.

Vishay Intertechnology, Inc., its affiliates, agents, and employees, and all persons acting on its or their behalf (collectively, "Vishay"), disclaim any and all liability for any errors, inaccuracies or incompleteness contained in any datasheet or in any other disclosure relating to any product.

Vishay makes no warranty, representation or guarantee regarding the suitability of the products for any particular purpose or the continuing production of any product. To the maximum extent permitted by applicable law, Vishay disclaims (i) any and all liability arising out of the application or use of any product, (ii) any and all liability, including without limitation special, consequential or incidental damages, and (iii) any and all implied warranties, including warranties of fitness for particular purpose, non-infringement and merchantability.

Statements regarding the suitability of products for certain types of applications are based on Vishay's knowledge of typical requirements that are often placed on Vishay products in generic applications. Such statements are not binding statements about the suitability of products for a particular application. It is the customer's responsibility to validate that a particular product with the properties described in the product specification is suitable for use in a particular application. Parameters provided in datasheets and / or specifications may vary in different applications and performance may vary over time. All operating parameters, including typical parameters, must be validated for each customer application by the customer's technical experts. Product specifications do not expand or otherwise modify Vishay's terms and conditions of purchase, including but not limited to the warranty expressed therein.

Hyperlinks included in this datasheet may direct users to third-party websites. These links are provided as a convenience and for informational purposes only. Inclusion of these hyperlinks does not constitute an endorsement or an approval by Vishay of any of the products, services or opinions of the corporation, organization or individual associated with the third-party website. Vishay disclaims any and all liability and bears no responsibility for the accuracy, legality or content of the third-party website or for that of subsequent links.

Except as expressly indicated in writing, Vishay products are not designed for use in medical, life-saving, or life-sustaining applications or for any other application in which the failure of the Vishay product could result in personal injury or death. Customers using or selling Vishay products not expressly indicated for use in such applications do so at their own risk. Please contact authorized Vishay personnel to obtain written terms and conditions regarding products designed for such applications.

No license, express or implied, by estoppel or otherwise, to any intellectual property rights is granted by this document or by any conduct of Vishay. Product names and markings noted herein may be trademarks of their respective owners.

X-ON Electronics

Largest Supplier of Electrical and Electronic Components

Click to view similar products for [Analogue Switch ICs category](#):

Click to view products by [Vishay manufacturer](#):

Other Similar products are found below :

[FSA3051TMX](#) [NLAS4684FCTCG](#) [NLAS5223BLMNR2G](#) [NLVAS4599DTT1G](#) [NLX2G66DMUTCG](#) [425541DB](#) [425528R](#) [099044FB](#)
[NLAS5123MNR2G](#) [PI5A4157CEX](#) [PI5A4599BCEX](#) [NLAS4717EPFCT1G](#) [PI5A3167CCEX](#) [SLAS3158MNR2G](#) [PI5A392AQE](#)
[PI5A4157ZUEX](#) [PI5A3166TAEX](#) [FSA634UCX](#) [TC4066BP\(N,F\)](#) [DG302BDJ-E3](#) [PI5A100QEX](#) [HV2605FG-G](#) [HV2301FG-G](#)
[RS2117YUTQK10](#) [RS2118YUTQK10](#) [RS2227XUTQK10](#) [ADG452BRZ-REEL7](#) [MAX4066ESD+](#) [MAX391CPE+](#) [MAX4730EXT+T](#)
[MAX314CPE+](#) [BU4066BCFV-E2](#) [MAX313CPE+](#) [BU4S66G2-TR](#) [NLAS3158MNR2G](#) [NLASB3157MTR2G](#) [TS3A4751PWR](#)
[NLAS4157DFT2G](#) [NLAS4599DFT2G](#) [NLASB3157DFT2G](#) [NLAST4599DFT2G](#) [NLAST4599DTT1G](#) [DG300BDJ-E3](#) [DG2503DB-T2-GE1](#)
[DG2502DB-T2-GE1](#) [TC4W53FU\(TE12L,F\)](#) [74HC2G66DC.125](#) [ADG619BRMZ-REEL](#) [ADG1611BRUZ-REEL7](#) [LTC201ACN#PBF](#)