

## 700 MHz, -3 dB Bandwidth; Single SPDT Analog Switch

### DESCRIPTION

DG3257 is a low  $R_{ON}$ , high bandwidth analog switch configured in single SPDT. It achieves  $5\ \Omega$  switch on resistance, greater than 700 MHz -3 dB bandwidth with 5 pF load, and a channel to channel crosstalk at -32 dB and isolation at -33 dB. Fabricated with high density sub micro CMOS process, the DG3257 provides low parasitic capacitance, handles bidirectional signal flow with minimized phase distortion. Guaranteed 1.4 V logic high threshold makes it possible to interface directly with low voltage MCUs.

The DG3257 is designed for a wide range of operating voltages from 1.65 V to 5.5 V that can be driven directly from one cell Li-ion battery. On-chip protection circuit protects against fault events when  $V+$  goes zero. Latch up current is 300 mA, as per JESD78, and its ESD tolerance exceeds 6 kV.

Packaged in ultra small  $\mu$ DFN6L (1 mm x 1 mm), it is ideal for portable high speed mix signal switching application.

As a committed partner to the community and the environment, Vishay Siliconix manufactures this product with lead (Pb)-free device termination.

The  $\mu$ DFN6L package has a nickel-palladium-gold device termination and is represented by the lead (Pb)-free “-GE4” suffix to the ordering part number. The nickel-palladium-gold device terminations meet all JEDEC® standards for reflow and MSL rating. As a further sign of Vishay Siliconix’s commitment, the DG3257 is fully RoHS-complaint.

### FEATURES

- 1.65 V to 5.5 V single supply operation
- Low resistance:  $5\ \Omega$ /typ. at 4.2 V
- Switch ON capacitance: 9 pF typical
- -3 dB bandwidth: 700 MHz
- Power down protection
- Signal swing over  $V+$  capable (when signal swing over  $V+$ , signal pin current: typically  $(V_S - 0.6\ V)/120\ \Omega$ )
- Control logic S pin voltage can go beyond  $V+$
- Break before make switching
- Latch up current: 300 mA (JESD78)
- ESD / HBM: 6 kV,
- ESD / CDM: 1 kV
- TTL/CMOS compatible
- Material categorization: for definitions of compliance please see [www.vishay.com/doc?99912](http://www.vishay.com/doc?99912)



RoHS COMPLIANT

### APPLICATIONS

- Smart phones
- Tablet, e-readers
- Camera, audio devices
- Computer and peripherals
- Data storage
- IoT
- Wearable
- Portable healthcare

### FUNCTIONAL BLOCK DIAGRAM AND PIN CONFIGURATION

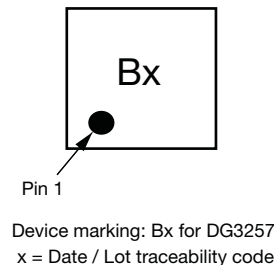
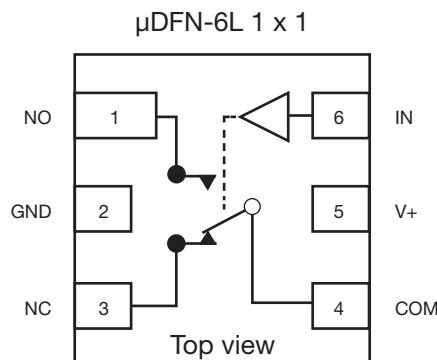

ORDERING INFORMATION		
TEMP. RANGE	PACKAGE	PART NUMBER
-40 °C to +85 °C	$\mu$ DFN-6L	DG3257DN-T1-GE4



TRUTH TABLE		
IN	NC	NO
0	ON	OFF
1	OFF	ON

PIN DESCRIPTIONS	
PIN NAME	DESCRIPTION
IN	Logic select Input
V+	Power pin
GND	Power ground pin
NC	Normal close data port
NO	Normal open data port
COM	Common data port

ABSOLUTE MAXIMUM RATINGS (T <sub>A</sub> = 25 °C, unless otherwise noted)			
PARAMETER	CONDITIONS	LIMITS	UNIT
V+, S	Reference to GND	-0.3 to +6	V
COM, NO, NC	Reference to GND	-0.3 to +6	
Maximum continuous switch current		± 50	mA
Maximum pulse switch current	Pulsed at 1 ms, 10 % duty cycle	± 100	
Thermal resistance		407	°C/W
ESD / HBM	EIA / JESD22-A114-A	6000	V
ESD / CDM	EIA / JESD22-C101A	1000	
Temperature			
Operating temperature		-40 to +85	°C
Max. operating junction temperature		150	
Operating junction temperature		125	
Storage temperature		-65 to +150	

Stresses beyond those listed under "Absolute Maximum Ratings" may cause permanent damage to the device. These are stress ratings only, and functional operation of the device at these or any other conditions beyond those indicated in the operational sections of the specifications is not implied. Exposure to absolute maximum rating conditions for extended periods may affect device reliability.

SPECIFICATIONS						
PARAMETER	SYMBOL	TEST CONDITIONS V <sub>+</sub> = 3 V, V <sub>INH</sub> = 1.3 V, V <sub>INL</sub> = 0.5 V OTHERWISE UNLESS SPECIFIED	+25 °C	-40 °C to +85 °C	TYP. <sup>a</sup> / MAX.	UNIT
Analog Switch						
Analog signal range	V <sub>ANALOG</sub>		0 to 5.5			V
Drain-source on-resistance	R <sub>DS(on)</sub>	V <sub>+</sub> = 1.8 V, V <sub>NC/NO</sub> = 0 V to V <sub>+</sub> , I <sub>S±</sub> = 8 mA	28	-	Typ.	Ω
			47	54	Max.	
		V <sub>+</sub> = 3 V, V <sub>NC/NO</sub> = 0.4 V, I <sub>S±</sub> = 8 mA	7	-	Typ.	
			8	9	Max.	
		V <sub>+</sub> = 3.6 V, V <sub>NC/NO</sub> = 0.4 V, I <sub>S±</sub> = 8 mA	6	-	Typ.	
			7	8	Max.	
		V <sub>+</sub> = 4.2 V, V <sub>NC/NO</sub> = 0.4 V, I <sub>S±</sub> = 8 mA	5	-	Typ.	
			6	7	Max.	
		V <sub>+</sub> = 5 V, V <sub>NC/NO</sub> = 0.4 V, I <sub>S±</sub> = 8 mA	5	-	Typ.	
			5.5	6	Max.	
On-resistance flatness	R <sub>flat(on)</sub>	V <sub>+</sub> = 3 V, V <sub>NC/NO</sub> = 0 V, 1 V, I <sub>S±</sub> = 8 mA	2	-	Typ.	
			3	6	Max.	
On-resistance matching	ΔR <sub>DS(on)</sub>	V <sub>+</sub> = 2.7 V to 5.5 V, V <sub>S</sub> = 0 V to V <sub>+</sub> , I <sub>S±</sub> = 8 mA	0.4	-	Typ.	
			0.6	0.8	Max.	
Switch off leakage current	I <sub>S</sub> /I <sub>d(off)</sub>	V <sub>+</sub> = 5.5 V, V <sub>COM</sub> = 1 V / 4.5 V, V <sub>NC/NO</sub> = 4.5 V / 1 V	± 0.2	-	Typ.	nA
			-	± 20	Max.	
Channel on leakage current	I <sub>d(on)</sub>	V <sub>+</sub> = 5.5 V, V <sub>COM</sub> = 1 V / 4.5 V, V <sub>NC/NO</sub> = open	± 0.2	-	Typ.	
			-	± 20	Max.	
Power down leakage	I <sub>COM(PD)</sub>	V <sub>+</sub> = 0 V, V <sub>COM</sub> = 4.5 V	1	-	Max.	μA



SPECIFICATIONS							
PARAMETER	SYMBOL	TEST CONDITIONS V+ = 3 V, VINH = 1.3 V, VINL = 0.5 V OTHERWISE UNLESS SPECIFIED	+25 °C	-40 °C to +85 °C	TYP. <sup>a</sup> / MAX.	UNIT	
<b>Digital Control</b>							
Input voltage high	VINH	V+ = 3 V	-	1.2	Min.	V	
		V+ = 5 V	-	1.4	Min.		
Input voltage low	VINL	V+ = 3 V	-	0.45	Max.		
		V+ = 5 V	-	0.5	Max.		
Input leakage	IIN	V+ = 0 V, 5.5 V, VIN = VGND or V+	0.001	-	Typ.	µA	
			-	0.23	Max.		
Digital input capacitance	CIN		5.6	-	Typ.	pF	
<b>Dynamic Characteristics</b>							
Break-before-make-time	tOPEN	VNO = VNC = 1.5 V; RL = 300 Ω, CL = 35 pF	6	-	Typ.	ns	
			-	2	Min.		
Turn-on time	tON	VNC = VNO = V+; RL = 50 Ω, CL = 35 pF	17	-	Typ.		
			40	50	Max.		
Turn-off time	tOFF		9	-	Typ.		
			35	45	Max.		
Propagation delay <sup>b</sup>	tPD			100	-	Typ.	ps
Charge injection <sup>b</sup>	QINJ		CL = 1 nF, RGEN = 0 Ω, VCOM = 1.5 V	4	-	Typ.	pC
Off-isolation <sup>b</sup>	OIRR	RL = 50 Ω, CL = 5 pF, f = 240 MHz	-33	-	Typ.	dB	
Crosstalk <sup>b</sup>	XTALK						-32
Insertion loss <sup>b</sup>		RL = 50 Ω, CL = 5 pF, f = 1 MHz	-0.62	-	Typ.		
Total harmonic distortion + Noise <sup>b</sup>	THD + N	RL = 600 Ω, VPP = 0.5 Vp-p, f = 20 Hz to 20 kHz	0.025	-	Typ.		%
Bandwidth, -3 dB <sup>b</sup>	BW	RL = 50 Ω, CL = 5 pF	714	-	Typ.	MHz	
Source off capacitance <sup>b</sup>	CS(off)	f = 240 MHz	3	-	Typ.	pF	
Drain on capacitance <sup>b</sup>	CD(on)		9	-	Typ.		
<b>Power Requirements</b>							
Power supply range		GND = 0 V	+1.65 / +5.5 min. / max.			V	
Power supply current	I+	Digital Inputs 0 V or V+, V+ = 2.7 V to 5.5 V	0.001	-	Typ.	µA	
			-	0.4	Max.		
		Digital inputs 1.8 V, V+ = 3 V	1	-	Typ.		
			-	1.5	Max.		

**Notes**

- a. Typical values are for design aid only, not guaranteed nor subject to production testing.
- b. Guarantee by design, not subjected to production test.

**TYPICAL CHARACTERISTICS** ( $T_A = 25\text{ }^\circ\text{C}$ , unless otherwise noted)

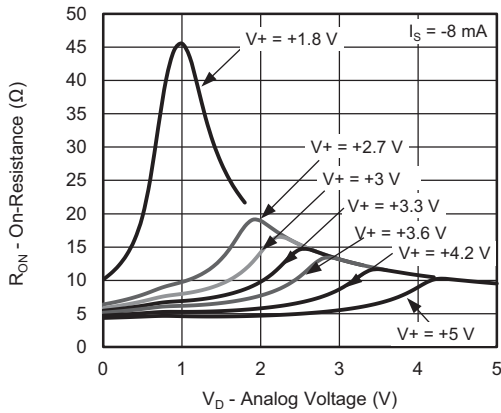

**RON vs.  $V_D$  and Single Supply Voltage**

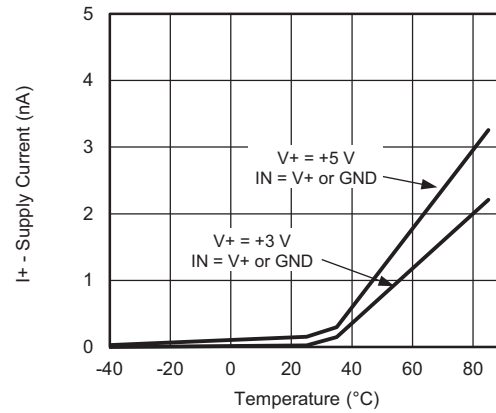

**Supply Current vs. Temperature**

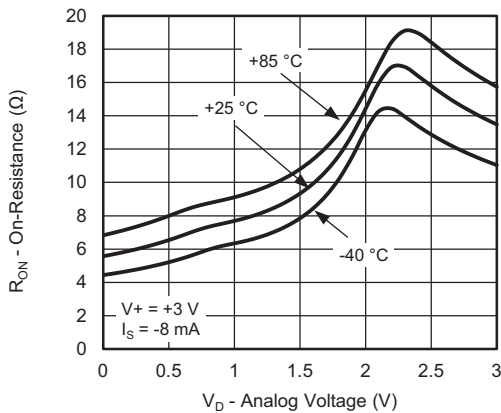

**RON vs. Analog Voltage and Temperature**

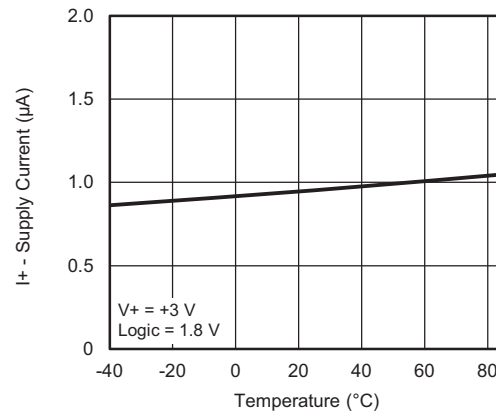

**Supply Current vs. Temperature**

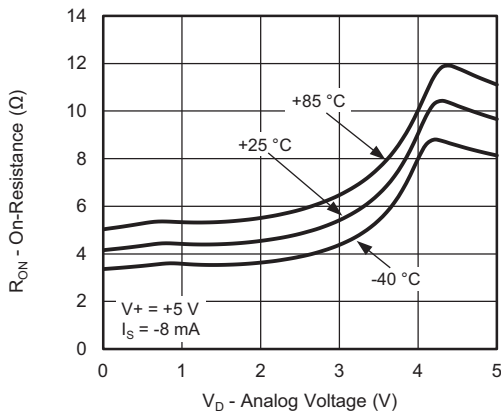

**RON vs. Analog Voltage and Temperature**

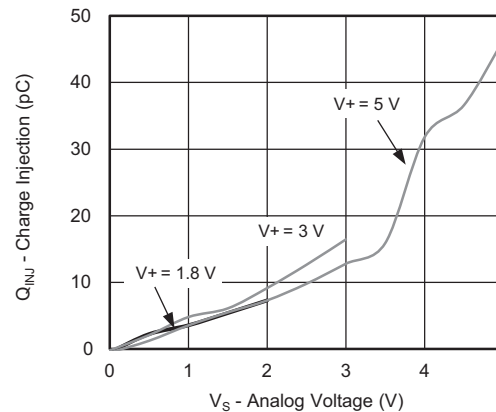

**Charge Injection vs. Analog Voltage**

**TYPICAL CHARACTERISTICS** ( $T_A = 25\text{ }^\circ\text{C}$ , unless otherwise noted)

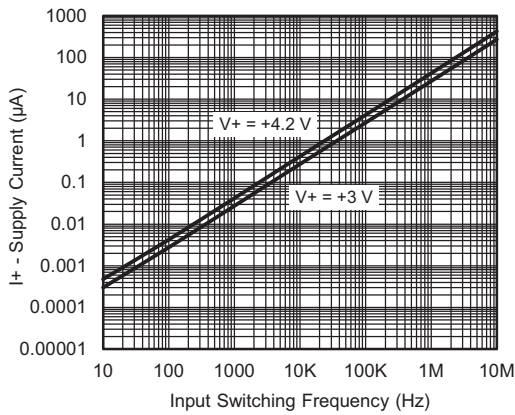

**Supply Current vs. Input Switching Frequency**

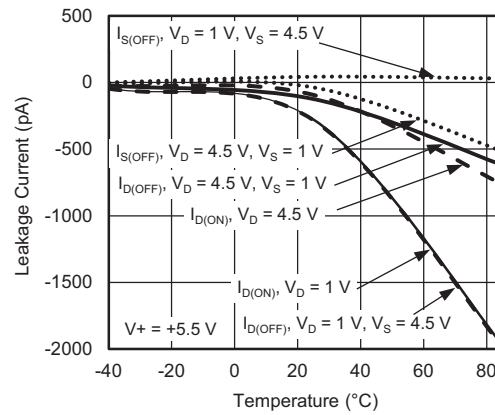

**Leakage Current vs. Temperature**

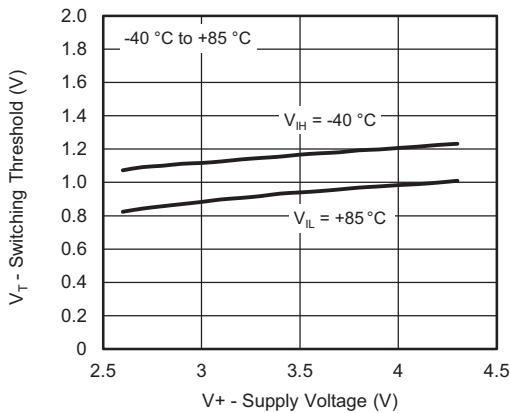

**Switching Threshold vs. Supply Voltage**

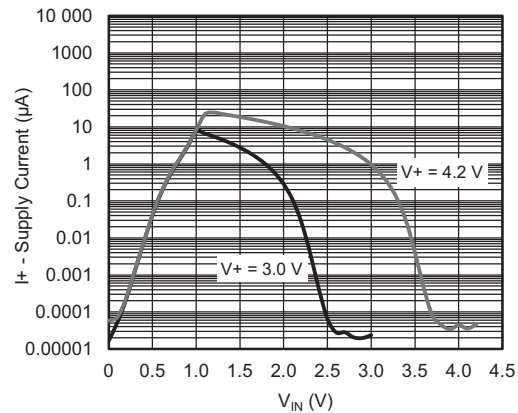

**Supply Current vs.  $V_{IN}$**

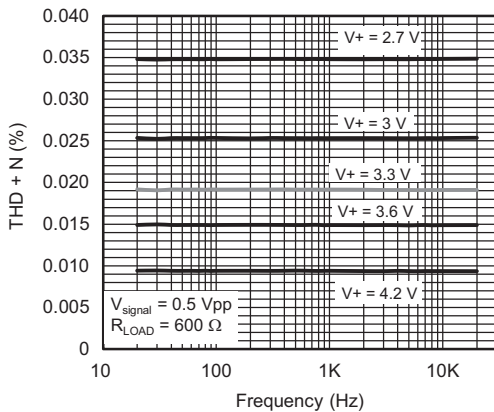

**THD + N vs. Frequency**

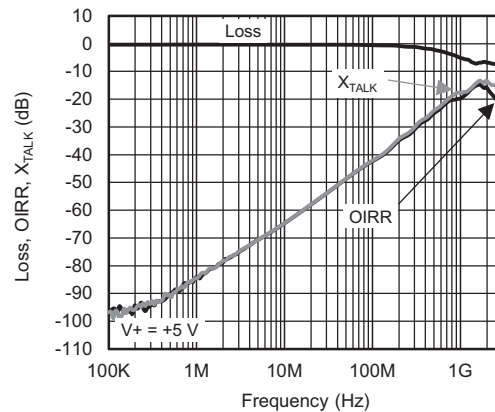

**$X_{TALK}$ ,  $V+ = 5\text{ V}$**

TEST CIRCUITS

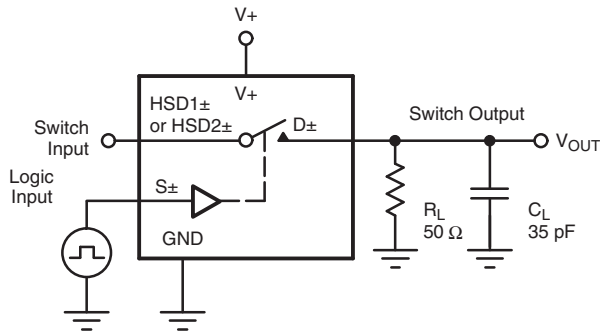

$C_L$  (includes fixture and stray capacitance)

$$V_{OUT} = D_{\pm} \left( \frac{R_L}{R_L + R_{ON}} \right)$$

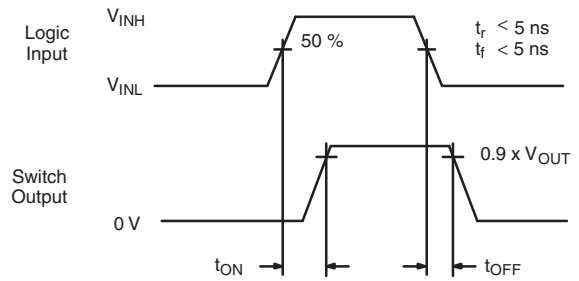

Logic "1" = Switch on  
Logic input waveforms inverted for switches that have the opposite logic sense.

Fig. 1 - Switching Time

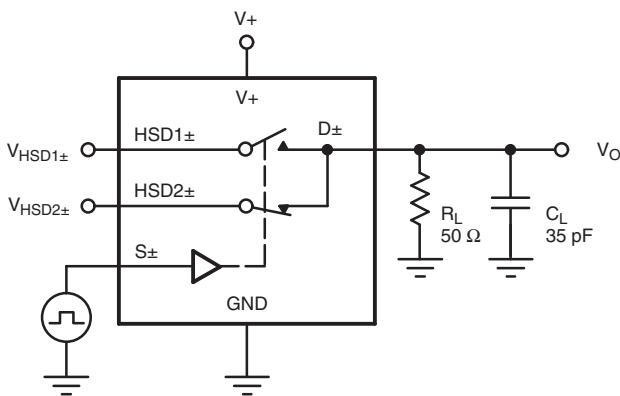

$C_L$  (includes fixture and stray capacitance)

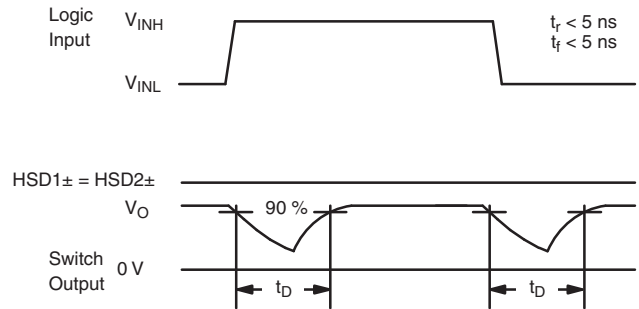
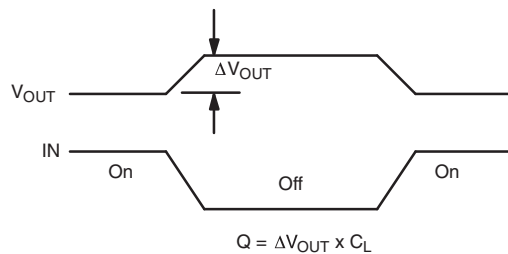
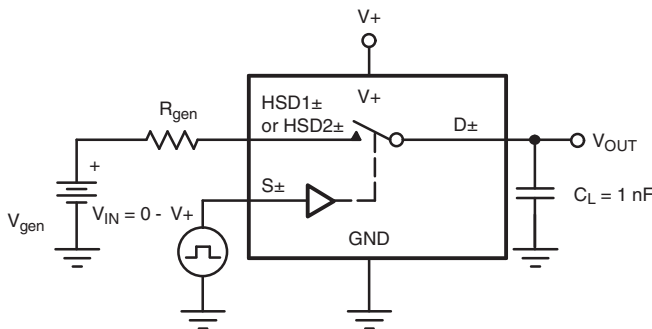
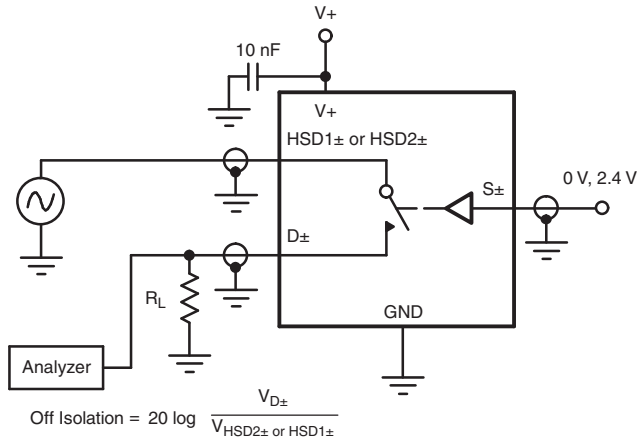
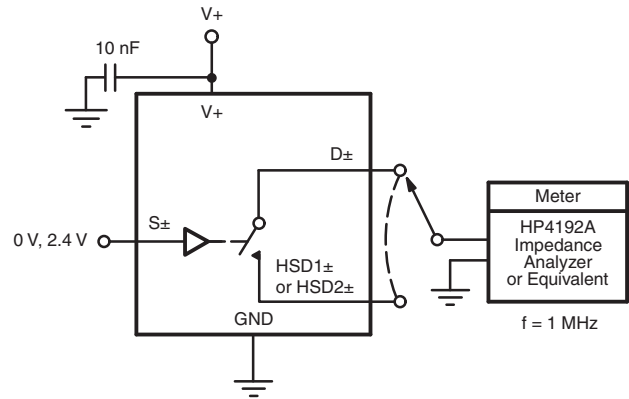

Fig. 2 - Break-Before-Make Interval



IN depends on switch configuration: input polarity determined by sense of switch.

Fig. 3 - Charge Injection

**TEST CIRCUITS**

**Fig. 4 - Off-Isolation**

**Fig. 5 - Channel Off / On Capacitance**

Vishay Siliconix maintains worldwide manufacturing capability. Products may be manufactured at one of several qualified locations. Reliability data for Silicon Technology and Package Reliability represent a composite of all qualified locations. For related documents such as package/tape drawings, part marking, and reliability data, see [www.vishay.com/ppg?75945](http://www.vishay.com/ppg?75945).

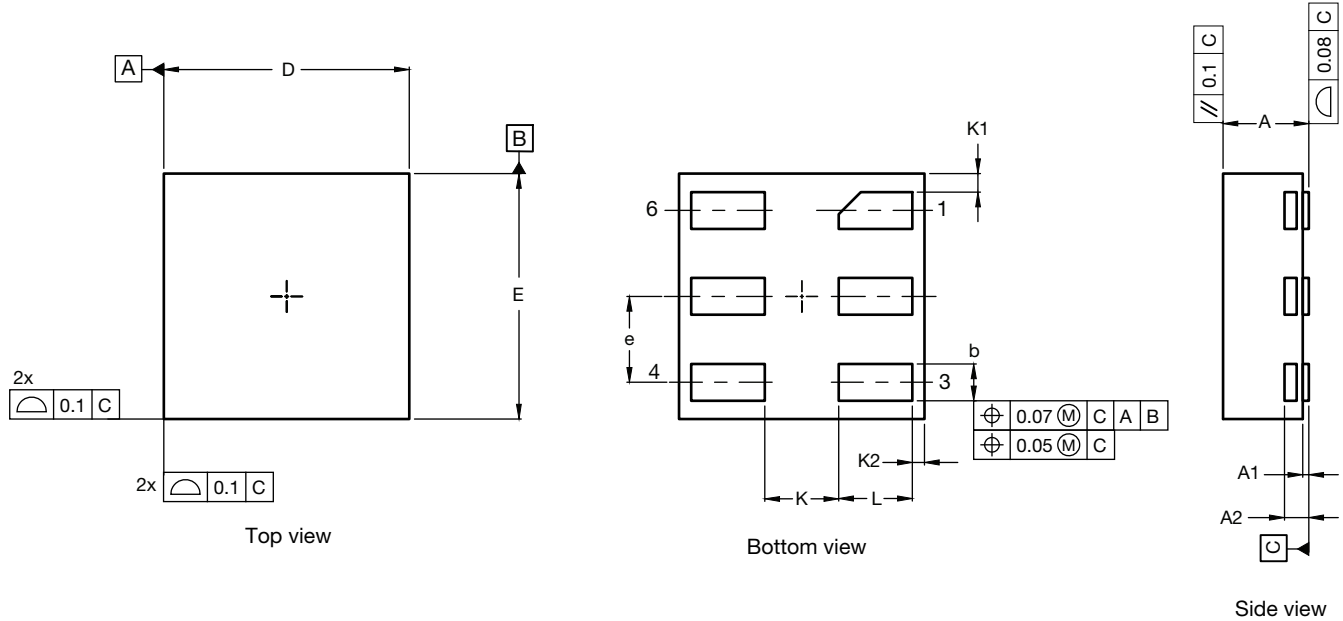

## μDFN-6L 1 mm x 1 mm Case Outline



DIM.	MILLIMETERS			INCHES		
	MIN.	NOM.	MAX.	MIN.	NOM.	MAX.
A	0.32	0.35	0.38	0.013	0.014	0.015
A1	0.00	-	0.05	0.000	-	0.002
A2	0.10 Ref.			0.004 Ref.		
b	0.12	0.15	0.18	0.005	0.006	0.007
D	0.95	1.00	1.05	0.037	0.039	0.041
E	0.95	1.00	1.05	0.037	0.039	0.041
e	0.35 BSC			0.014 BSC		
K	0.30 Ref.			0.012 Ref.		
K1	0.075 Ref.			0.003 Ref.		
K2	0.05 Ref.			0.002 Ref.		
L	0.27	0.30	0.33	0.011	0.012	0.013

**Notes**

- (1) Use millimeters as the primary measurement.
- (2) Dimensioning and tolerances conform to ASME Y14.5M-1994.
- (3) N is the number of terminals.  
Nd and Ne is the number of terminals in each D and E site respectively.
- (4) Dimensions b applies to plated terminal and is measured between 0.15 mm and 0.30 mm from terminal tip.
- (5) The pin 1 identifier must be existed on the top surface of the package by using indentation mark or other feature of package body.
- (6) Package warpage max. 0.05 mm.

ECN: T16-0553-Rev. A, 26-Sep-16  
 DWG: 6053





## **Disclaimer**

ALL PRODUCT, PRODUCT SPECIFICATIONS AND DATA ARE SUBJECT TO CHANGE WITHOUT NOTICE TO IMPROVE RELIABILITY, FUNCTION OR DESIGN OR OTHERWISE.

Vishay Intertechnology, Inc., its affiliates, agents, and employees, and all persons acting on its or their behalf (collectively, "Vishay"), disclaim any and all liability for any errors, inaccuracies or incompleteness contained in any datasheet or in any other disclosure relating to any product.

Vishay makes no warranty, representation or guarantee regarding the suitability of the products for any particular purpose or the continuing production of any product. To the maximum extent permitted by applicable law, Vishay disclaims (i) any and all liability arising out of the application or use of any product, (ii) any and all liability, including without limitation special, consequential or incidental damages, and (iii) any and all implied warranties, including warranties of fitness for particular purpose, non-infringement and merchantability.

Statements regarding the suitability of products for certain types of applications are based on Vishay's knowledge of typical requirements that are often placed on Vishay products in generic applications. Such statements are not binding statements about the suitability of products for a particular application. It is the customer's responsibility to validate that a particular product with the properties described in the product specification is suitable for use in a particular application. Parameters provided in datasheets and / or specifications may vary in different applications and performance may vary over time. All operating parameters, including typical parameters, must be validated for each customer application by the customer's technical experts. Product specifications do not expand or otherwise modify Vishay's terms and conditions of purchase, including but not limited to the warranty expressed therein.

Except as expressly indicated in writing, Vishay products are not designed for use in medical, life-saving, or life-sustaining applications or for any other application in which the failure of the Vishay product could result in personal injury or death. Customers using or selling Vishay products not expressly indicated for use in such applications do so at their own risk. Please contact authorized Vishay personnel to obtain written terms and conditions regarding products designed for such applications.

No license, express or implied, by estoppel or otherwise, to any intellectual property rights is granted by this document or by any conduct of Vishay. Product names and markings noted herein may be trademarks of their respective owners.

## X-ON Electronics

Largest Supplier of Electrical and Electronic Components

*Click to view similar products for [Analogue Switch ICs category](#):*

*Click to view products by [Vishay manufacturer](#):*

Other Similar products are found below :

[FSA3051TMX](#) [NLAS4684FCTCG](#) [NLAS5223BLMNR2G](#) [NLVAS4599DTT1G](#) [NLX2G66DMUTCG](#) [425541DB](#) [425528R](#) [099044FB](#)  
[NLAS5123MNR2G](#) [PI5A4157CEX](#) [PI5A4599BCEX](#) [NLAS4717EPFCT1G](#) [PI5A3167CCEX](#) [SLAS3158MNR2G](#) [PI5A392AQE](#)  
[PI5A4157ZUEX](#) [PI5A3166TAEX](#) [FSA634UCX](#) [TC4066BP\(N,F\)](#) [DG302BDJ-E3](#) [PI5A100QEX](#) [HV2605FG-G](#) [HV2301FG-G](#)  
[RS2117YUTQK10](#) [RS2118YUTQK10](#) [RS2227XUTQK10](#) [ADG452BRZ-REEL7](#) [MAX4066ESD+](#) [MAX391CPE+](#) [MAX4730EXT+T](#)  
[MAX314CPE+](#) [BU4066BCFV-E2](#) [MAX313CPE+](#) [BU4S66G2-TR](#) [NLASB3157MTR2G](#) [TS3A4751PWR](#) [NLAST4599DFT2G](#)  
[NLAST4599DTT1G](#) [DG300BDJ-E3](#) [DG2503DB-T2-GE1](#) [TC4W53FU\(TE12L,F\)](#) [74HC2G66DC.125](#) [ADG619BRMZ-REEL](#)  
[LTC201ACN#PBF](#) [74LV4066DB,118](#) [FSA2275AUMX](#) [DIO1500WL12](#) [ADG742BKSZ-REEL7](#) [DIO1269LP10](#) [DG307BDJ-E3](#)