

Precision Monolithic Quad SPST CMOS Analog Switches

DESCRIPTION

The DG411HS series of monolithic quad analog switches was designed to provide high speed, low error switching of precision analog signals. Combining low power (0.35 μ W) with high speed (t_{ON} : 68 ns), the DG411HS family is ideally suited for portable and battery powered industrial and military applications.

To achieve high-voltage ratings and superior switching performance, the DG411HS series was built on Vishay Siliconix's high voltage silicon gate process. An epitaxial layer prevents latchup.

Each switch conducts equally well in both directions when on, and blocks input voltages up to the supply levels when off.

The DG411HS and DG412HS respond to opposite control logic as shown in the Truth Table. The DG413HS has two normally open and two normally closed switches.

FEATURES

- 44 V supply max. rating
- ± 15 V analog signal range
- On-resistance - $R_{DS(on)}$: 25 Ω
- Fast switching - t_{ON} : 68 ns
- Ultra low power - P_D : 0.35 μ W
- TTL, CMOS compatible
- Single supply capability



BENEFITS

- Widest dynamic range
- Low signal errors and distortion
- Break-before-make switching action
- Simple interfacing

APPLICATIONS

- Precision automatic test equipment
- Precision data acquisition
- Communication systems
- Battery powered systems
- Computer peripherals

FUNCTIONAL BLOCK DIAGRAM AND PIN CONFIGURATION

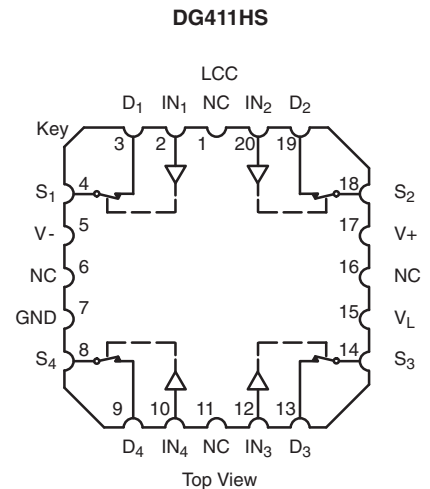
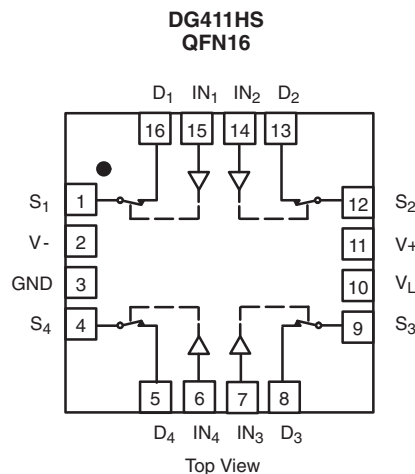
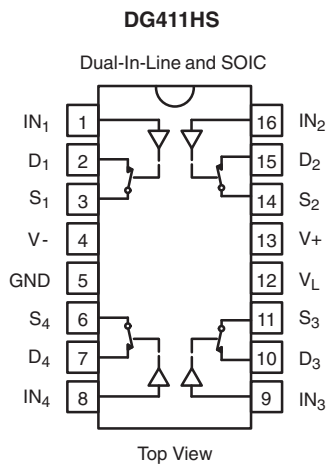

TRUTH TABLE		
Logic	DG411HS	DG412HS
0	ON	OFF
1	OFF	ON

* Pb containing terminations are not RoHS compliant, exemptions may apply

FUNCTIONAL BLOCK DIAGRAM AND PIN CONFIGURATION

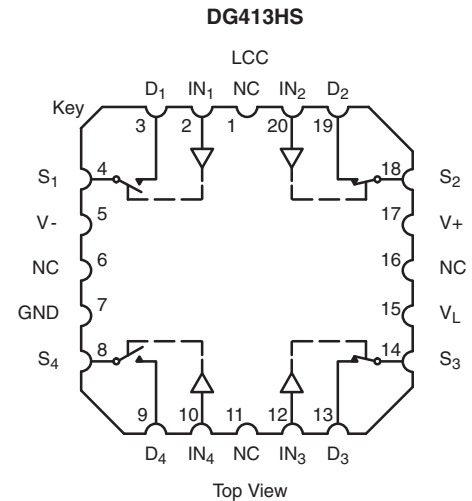
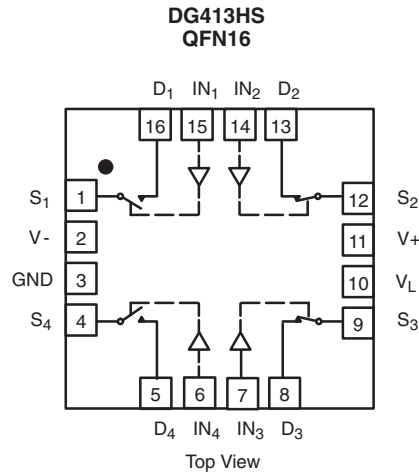
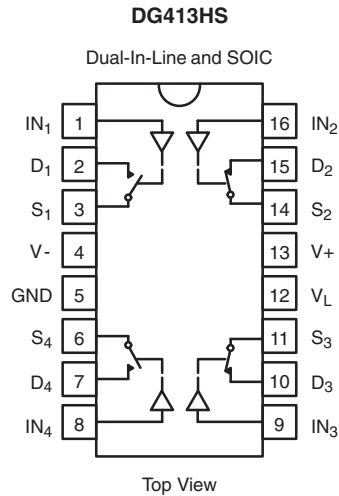

TRUTH TABLE		
Logic	SW ₁ , SW ₄	SW ₂ , SW ₃
0	OFF	ON
1	ON	OFF

ORDERING INFORMATION		
Temp. Range	Package	Part Number
DG411HS, DG412HS		
- 40 °C to 85 °C	16-Pin Plastic DIP	DG411HSDJ DG411HSDJ-E3
		DG412HSDJ DG412HSDJ-E3
	16-Pin Narrow SOIC	DG411HSDY DG411HSDY-E3 DG411HSDY-T1 DG411HSDY-T1-E3
		DG412HSDY DG412HSDY-E3 DG412HSDY-T1 DG412HSDY-T1-E3
	16-Pin QFN 4 x 4 mm (Variation 1)	DG411HSDN-T1-E4
		DG412HSDN-T1-E4
DG413HS		
- 40 °C to 85 °C	16-Pin Plastic DIP	DG413HSDJ DG413HSDJ-E3
	16-Pin Narrow SOIC	DG413HSDY DG413HSDY-E3 DG413HSDY-T1 DG413HSDY-T1-E3
		DG413HSDN-T1-E4
		DG413HSDN-T1-E4



ABSOLUTE MAXIMUM RATINGS			
Parameter		Limit	Unit
V+ to V-		44	V
GND to V-		25	
V _L		(GND - 0.3) to (V+) + 0.3	
Digital Inputs ^a , V _S , V _D		(V-) - 2 to (V+) + 2 or 30 mA, whichever occurs first	
Continuous Current (Any terminal)		30	mA
Peak Current, S or D (Pulsed 1 ms, 10 % duty cycle)		100	
Storage Temperature	(AK, AZ Suffix)	- 65 to 150	°C
	(DJ, DY, DN Suffix)	- 65 to 125	
Power Dissipation (Package) ^b	16-Pin Plastic DIP ^c	470	mW
	16-Pin Narrow SOIC ^d	600	
	16-Pin CerDIP ^e	900	
	LCC-20 ^e	900	
	16-Pin (4 x 4 mm) QFN ^f	1880	

Notes:

- a. Signals on S_X, D_X, or IN_X exceeding V+ or V- will be clamped by internal diodes. Limit forward diode current to maximum current ratings.
- b. All leads welded or soldered to PC board.
- c. Derate 6 mW/°C above 25 °C.
- d. Derate 7.6 mW/°C above 75 °C.
- e. Derate 12 mW/°C above 75 °C.
- f. Derate 23.5 mW/°C above 70 °C.

SPECIFICATIONS ^a									
Parameter	Symbol	Test Conditions Unless Specified V+ = 15 V, V- = - 15 V V _L = 5 V, V _{IN} = 2.4 V, 0.8 V ^f	Temp. ^b	Typ. ^c	A Suffix - 55 °C to 125 °C		D Suffix - 40 °C to 85 °C		Unit
					Min. ^d	Max. ^d	Min. ^d	Max. ^d	
Analog Switch									
Analog Signal Range ^e	V _{ANALOG}		Full		- 15	15	- 15	15	V
Drain-Source On-Resistance	R _{DS(on)}	V+ = 13.5 V, V- = - 13.5 V I _S = - 10 mA, V _D = ± 8.5 V	Room Full	25		35 45		35 45	Ω
Switch Off Leakage Current	I _{S(off)}	V+ = 16.5 V, V- = - 16.5 V V _D = ± 15.5 mA, V _S = ± 15.5 V	Room Full	± 0.1	- 0.25 - 20	0.25 20	- 0.25 - 5	0.25 5	nA
	I _{D(off)}		Room Full	± 0.1	- 0.25 - 20	0.25 20	- 0.25 - 5	0.25 5	
Channel On Leakage Current	I _{D(on)}	V+ = 16.5 V, V- = - 16.5 V V _D = V _S = ± 15.5 V	Room Full	± 0.1	- 0.4 - 40	0.4 40	- 0.4 - 10	0.4 10	
Digital Control									
Input Current, V _{IN} Low	I _{IL}	V _{IN} under test = 0.8 V	Full	0.005	- 0.5	0.5	- 0.5	0.5	μA
Input Current, V _{IN} High	I _{IH}	V _{IN} under test = 2.4 V	Full	0.005	- 0.5	0.5	- 0.5	0.5	
Input Capacitance ^e	C _{IN}	f = 1 MHz	Room	5					pF
Dynamic Characteristics									
Turn-On Time	t _{ON}	R _L = 300 Ω, C _L = 35 pF V _S = ± 10 V, see figure 2	Room Full	68		105 127		105 116	ns
Turn-Off Time	t _{OFF}		Room Full	42		80 94		80 90	
Break-Before-Make Time Delay	t _D	DG413HS only, V _S = 10 V R _L = 300 Ω, C _L = 35 pF	Room	20					
Charge Injection ^e	Q	V _g = 0 V, R _g = 0 Ω, C _L = 10 nF	Room	22					pC

SPECIFICATIONS ^a									
Parameter	Symbol	Test Conditions Unless Specified V ₊ = 15 V, V ₋ = -15 V V _L = 5 V, V _{IN} = 2.4 V, 0.8 V ^f	Temp. ^b	Typ. ^c	A Suffix - 55 °C to 125 °C		D Suffix - 40 °C to 85 °C		Unit
					Min. ^d	Max. ^d	Min. ^d	Max. ^d	
Dynamic Characteristics (Cont'd)									
Off Isolation ^e	OIRR	R _L = 50 Ω, C _L = 5 pF f = 1 MHz	Room	- 91					dB
Channel-to-Channel Crosstalk ^e	X _{TALK}		Room	- 88					
Source Off Capacitance ^e	C _{S(off)}	f = 1 MHz	Room	12					pF
Drain Off Capacitance ^e	C _{D(off)}		Room	12					
Channel On Capacitance ^e	C _{D(on)}		Room	30					
Power Supplies									
Positive Supply Current	I ₊	V ₊ = 16.5 V, V ₋ = -16.5 V V _{IN} = 0 or 5 V	Room Full	0.0001		1 5		1 5	μA
Negative Supply Current	I ₋		Room Full	- 0.0001	- 1 - 5		- 1 - 5		
Logic Supply Current	I _L		Room Full	0.0001		1 5		1 5	
Ground Current	I _{GND}		Room Full	- 0.0001	- 1 - 5		- 1 - 5		

SPECIFICATIONS ^a (for Unipolar Supplies)									
Parameter	Symbol	Test Conditions Unless Specified V ₊ = 12 V, V ₋ = 0 V V _L = 5 V, V _{IN} = 2.4 V, 0.8 V ^f	Temp. ^b	Typ. ^c	A Suffix - 55 °C to 125 °C		D Suffix - 40 °C to 85 °C		Unit
					Min. ^d	Max. ^d	Min. ^d	Max. ^d	
Analog Switch									
Analog Signal Range ^e	V _{ANALOG}		Full			12		12	V
Drain-Source On-Resistance	R _{DS(on)}	V ₊ = 10.8 V, I _S = -10 mA V _D = 3 V, 8 V	Room Full	49		80 100		80 100	Ω
Dynamic Characteristics									
Turn-On Time	t _{ON}	R _L = 300 Ω, C _L = 35 pF V _S = 8 V, see figure 2	Room Hot	95		140 180		140 160	ns
Turn-Off Time	t _{OFF}		Room Hot	36		70 79		70 74	
Break-Before-Make Time Delay	t _D	DG413HS only, V _S = 8 V R _L = 300 Ω, C _L = 35 pF	Room	60					
Charge Injection	Q	V _g = 6 V, R _g = 0 Ω, C _L = 1 nF	Room	60					pC
Power Supplies									
Positive Supply Current	I ₊	V ₊ = 13.2 V, V _{IN} = 0 or 5 V	Room Hot	0.0001		1 5		1 5	μA
Negative Supply Current	I ₋		Room Hot	- 0.0001	- 1 - 5		- 1 - 5		
Logic Supply Current	I _L		Room Hot	0.0001		1 5		1 5	
Ground Current	I _{GND}		Room Hot	- 0.0001	- 1 - 5		- 1 - 5		

Notes:

- Refer to PROCESS OPTION FLOWCHART.
- Room = 25 °C, Full = as determined by the operating temperature suffix.
- Typical values are for DESIGN AID ONLY, not guaranteed nor subject to production testing.
- The algebraic convention whereby the most negative value is a minimum and the most positive a maximum, is used in this data sheet.
- Guaranteed by design, not subject to production test.
- V_{IN} = input voltage to perform proper function.

Stresses beyond those listed under "Absolute Maximum Ratings" may cause permanent damage to the device. These are stress ratings only, and functional operation of the device at these or any other conditions beyond those indicated in the operational sections of the specifications is not implied. Exposure to absolute maximum rating conditions for extended periods may affect device reliability.

TYPICAL CHARACTERISTICS (25 °C, unless otherwise noted)

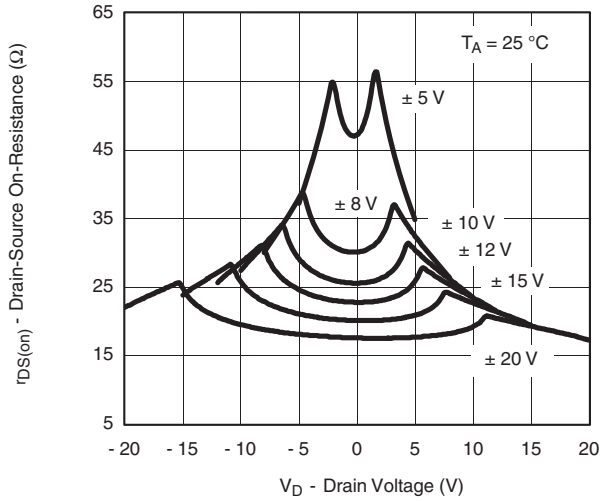

On-Resistance vs. V_D and Dual Supply Voltage

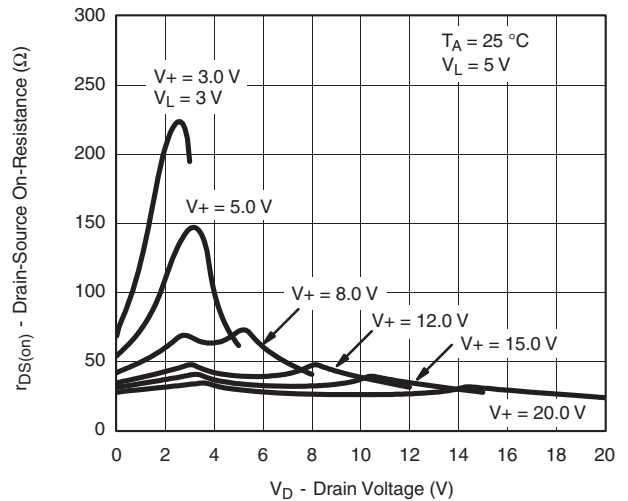

On-Resistance vs. V_D and Unipolar Supply Voltage

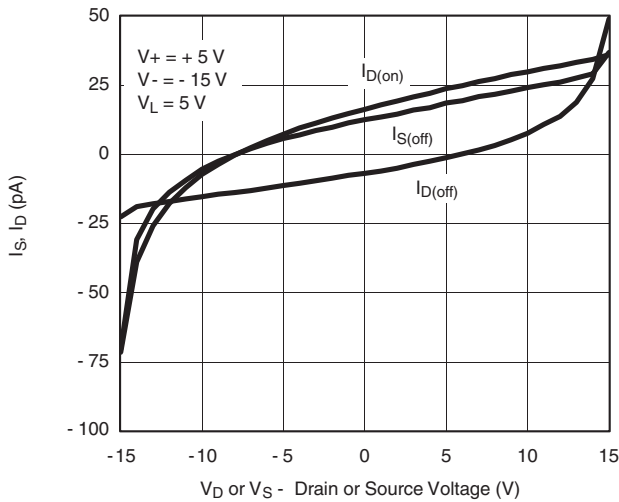

Leakage Current vs. Analog Voltage

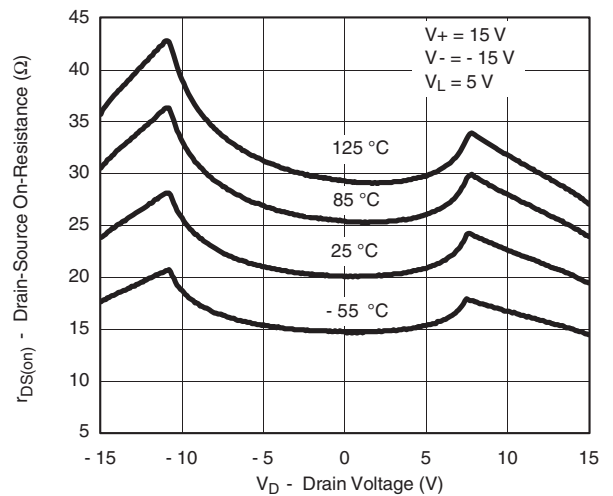

On-Resistance vs. V_D and Temperature

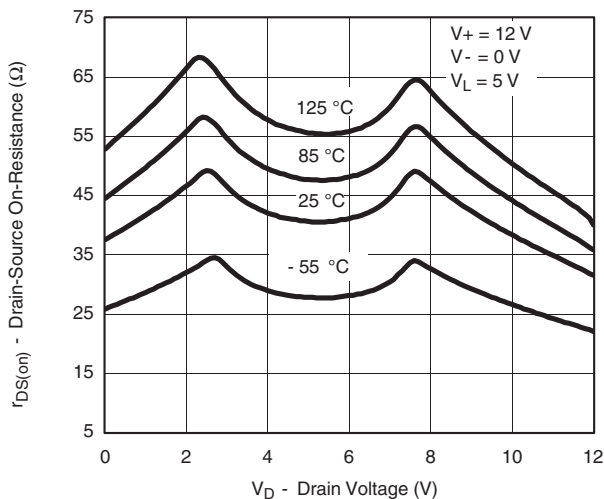

On-Resistance vs. V_D and Temperature

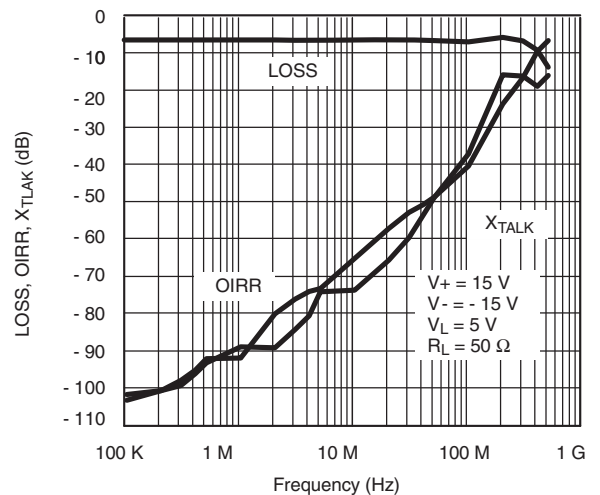

Insertion Loss, Off-Isolation, Crosstalk vs. Frequency

TYPICAL CHARACTERISTICS (25 °C, unless otherwise noted)

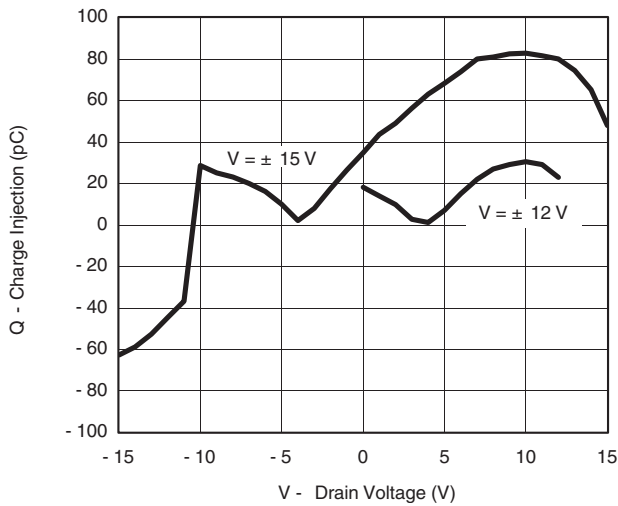

Charge Injection vs. Analog Voltage

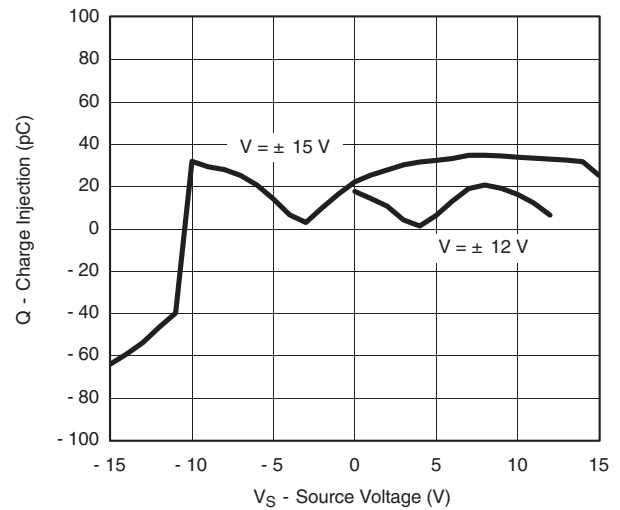

Charge Injection vs. Analog Voltage

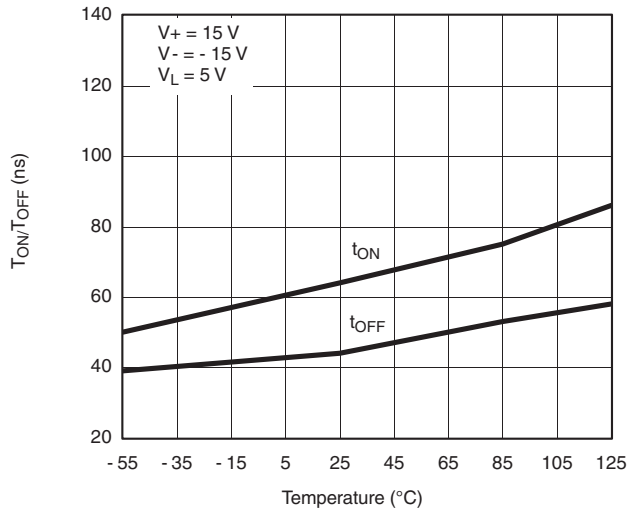

Switching Time vs. Temperature

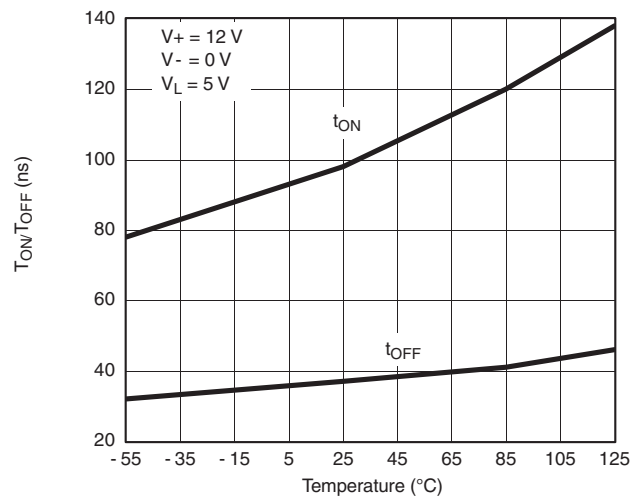

Switching Time vs. Temperature

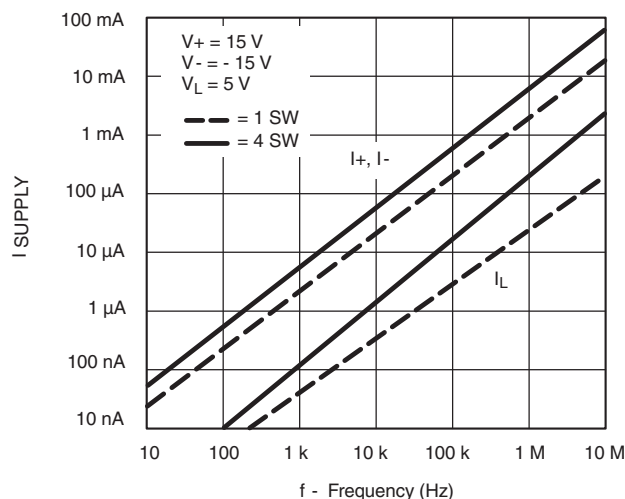

Supply Current vs. Input Switching Frequency

SCHEMATIC DIAGRAM (Typical Channel)

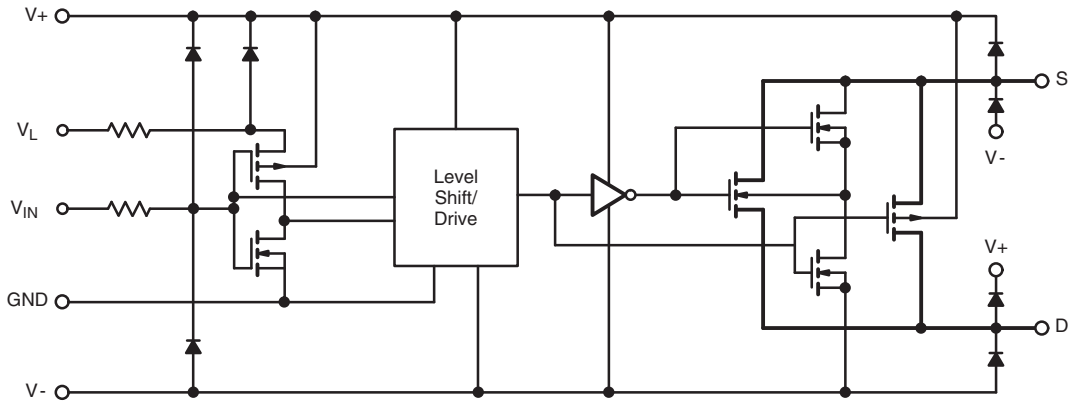
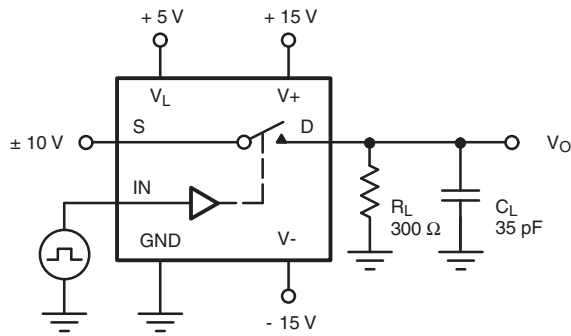

Figure 1.

TEST CIRCUITS



C_L (includes fixture and stray capacitance)

$$V_O = V_S \frac{R_L}{R_L + r_{DS(on)}}$$

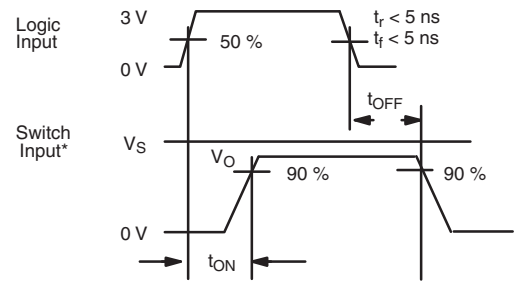

Note: Logic input waveform is inverted for switches that have the opposite logic sense control

Figure 2. Switching Time

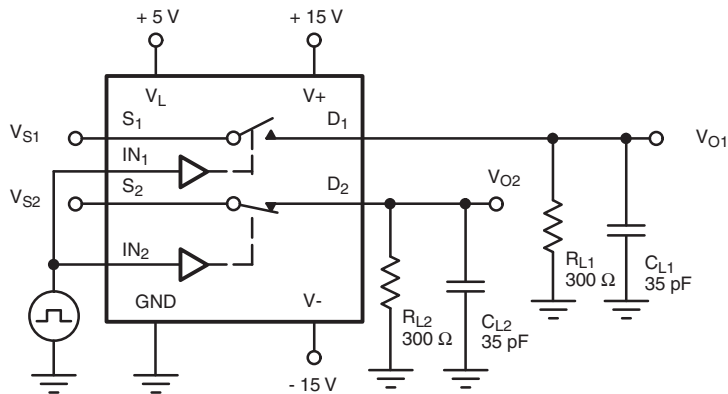

C_L (includes fixture and stray capacitance)

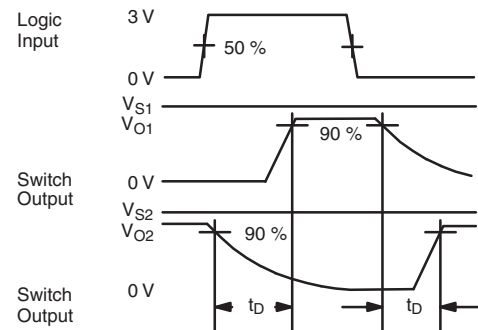

Figure 3. Break-Before-Make (DG413HS)

TEST CIRCUITS

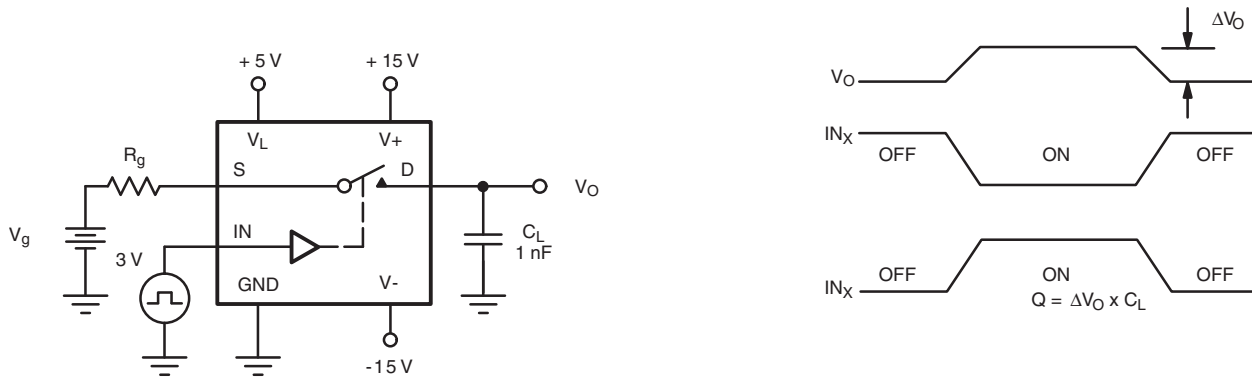

Figure 4. Charge Injection

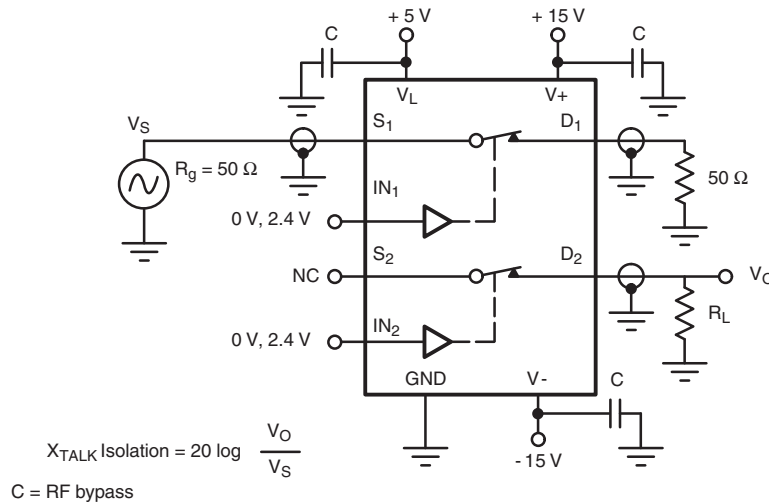

Figure 5. Crosstalk

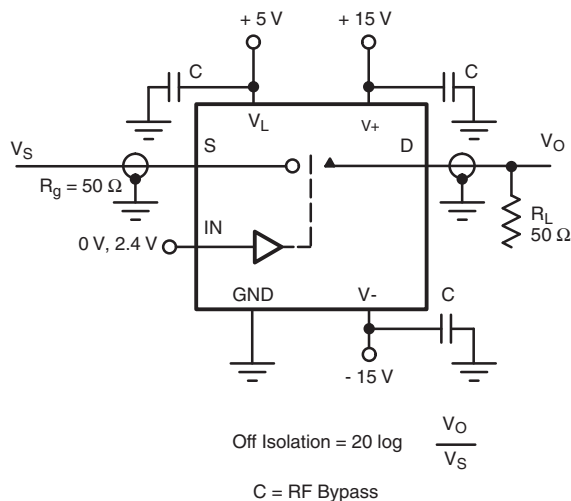

Figure 6. Off-Isolation

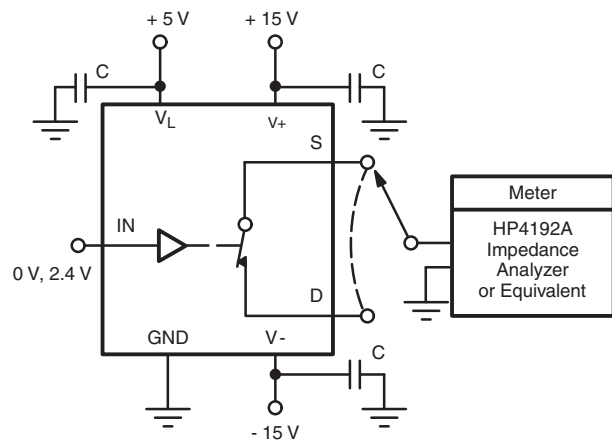

Figure 7. Source/Drain Capacitances

Vishay Siliconix maintains worldwide manufacturing capability. Products may be manufactured at one of several qualified locations. Reliability data for Silicon Technology and Package Reliability represent a composite of all qualified locations. For related documents such as package/tape drawings, part marking, and reliability data, see www.vishay.com/ppg?72053.



SOIC (NARROW): 16-LEAD
JEDEC Part Number: MS-012



Dim	MILLIMETERS		INCHES	
	Min	Max	Min	Max
A	1.35	1.75	0.053	0.069
A ₁	0.10	0.20	0.004	0.008
B	0.38	0.51	0.015	0.020
C	0.18	0.23	0.007	0.009
D	9.80	10.00	0.385	0.393
E	3.80	4.00	0.149	0.157
e	1.27 BSC		0.050 BSC	
H	5.80	6.20	0.228	0.244
L	0.50	0.93	0.020	0.037
∅	0°	8°	0°	8°

ECN: S-03946—Rev. F, 09-Jul-01
DWG: 5300

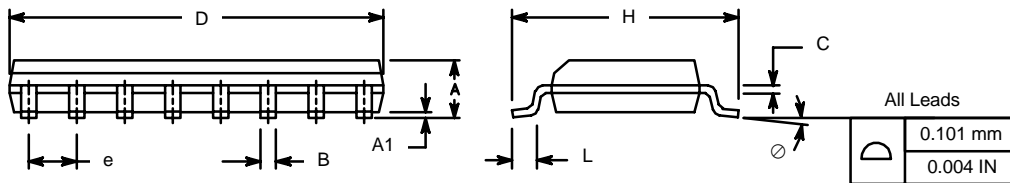

PDIP: 16-LEAD



Dim	MILLIMETERS		INCHES	
	Min	Max	Min	Max
A	3.81	5.08	0.150	0.200
A₁	0.38	1.27	0.015	0.050
B	0.38	0.51	0.015	0.020
B₁	0.89	1.65	0.035	0.065
C	0.20	0.30	0.008	0.012
D	18.93	21.33	0.745	0.840
E	7.62	8.26	0.300	0.325
E₁	5.59	7.11	0.220	0.280
e₁	2.29	2.79	0.090	0.110
e_A	7.37	7.87	0.290	0.310
L	2.79	3.81	0.110	0.150
Q₁	1.27	2.03	0.050	0.080
S	0.38	1.52	.015	0.060

ECN: S-03946—Rev. D, 09-Jul-01
DWG: 5482

QFN 4x4-16L Case Outline

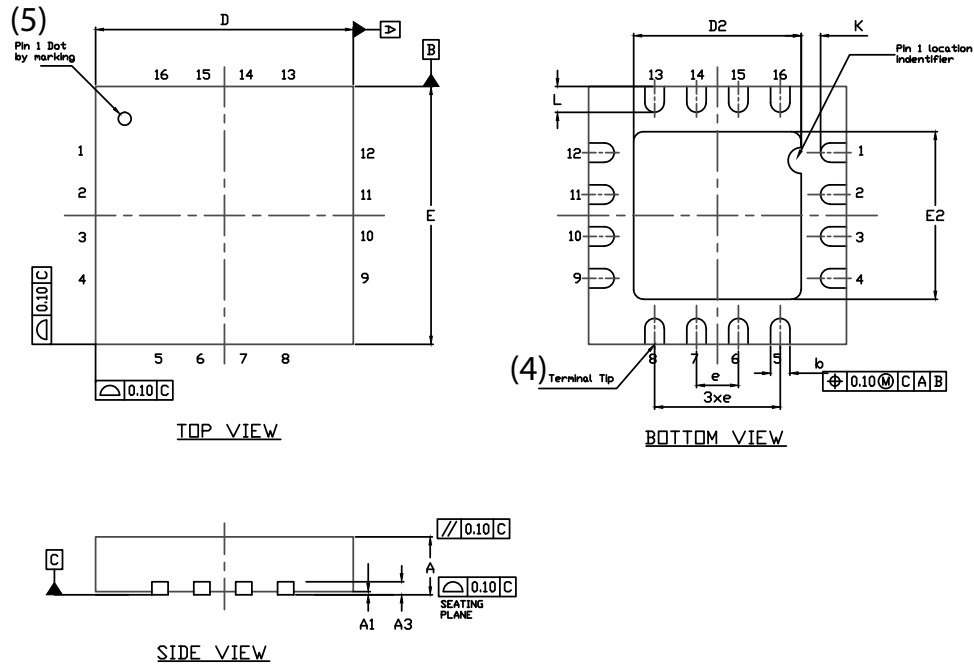

DIM	VARIATION 1						VARIATION 2					
	MILLIMETERS ⁽¹⁾			INCHES			MILLIMETERS ⁽¹⁾			INCHES		
	MIN.	NOM.	MAX.	MIN.	NOM.	MAX.	MIN.	NOM.	MAX.	MIN.	NOM.	MAX.
A	0.75	0.85	0.95	0.029	0.033	0.037	0.75	0.85	0.95	0.029	0.033	0.037
A1	0	-	0.05	0	-	0.002	0	-	0.05	0	-	0.002
A3	0.20 ref.			0.008 ref.			0.20 ref.			0.008 ref.		
b	0.25	0.30	0.35	0.010	0.012	0.014	0.25	0.30	0.35	0.010	0.012	0.014
D	4.00 BSC			0.157 BSC			4.00 BSC			0.157 BSC		
D2	2.0	2.1	2.2	0.079	0.083	0.087	2.5	2.6	2.7	0.098	0.102	0.106
e	0.65 BSC			0.026 BSC			0.65 BSC			0.026 BSC		
E	4.00 BSC			0.157 BSC			4.00 BSC			0.157 BSC		
E2	2.0	2.1	2.2	0.079	0.083	0.087	2.5	2.6	2.7	0.098	0.102	0.106
K	0.20 min.			0.008 min.			0.20 min.			0.008 min.		
L	0.5	0.6	0.7	0.020	0.024	0.028	0.3	0.4	0.5	0.012	0.016	0.020
N ⁽³⁾	16			16			16			16		
Nd ⁽³⁾	4			4			4			4		
Ne ⁽³⁾	4			4			4			4		

Notes

- (1) Use millimeters as the primary measurement.
- (2) Dimensioning and tolerances conform to ASME Y14.5M. - 1994.
- (3) N is the number of terminals. Nd and Ne is the number of terminals in each D and E site respectively.
- (4) Dimensions b applies to plated terminal and is measured between 0.15 mm and 0.30 mm from terminal tip.
- (5) The pin 1 identifier must be existed on the top surface of the package by using identification mark or other feature of package body.
- (6) Package warpage max. 0.05 mm.

ECN: S13-0893-Rev. B, 22-Apr-13
 DWG: 5890

RECOMMENDED MINIMUM PADS FOR SO-16

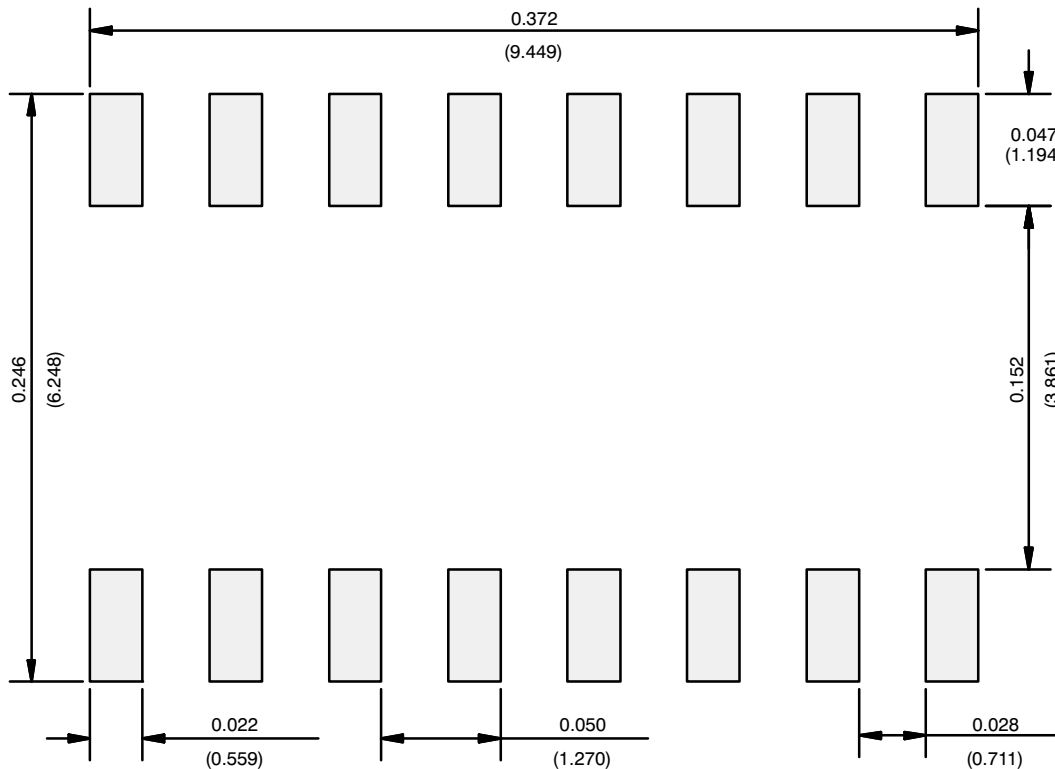

Recommended Minimum Pads
Dimensions in Inches/(mm)

[Return to Index](#)



Disclaimer

ALL PRODUCT, PRODUCT SPECIFICATIONS AND DATA ARE SUBJECT TO CHANGE WITHOUT NOTICE TO IMPROVE RELIABILITY, FUNCTION OR DESIGN OR OTHERWISE.

Vishay Intertechnology, Inc., its affiliates, agents, and employees, and all persons acting on its or their behalf (collectively, "Vishay"), disclaim any and all liability for any errors, inaccuracies or incompleteness contained in any datasheet or in any other disclosure relating to any product.

Vishay makes no warranty, representation or guarantee regarding the suitability of the products for any particular purpose or the continuing production of any product. To the maximum extent permitted by applicable law, Vishay disclaims (i) any and all liability arising out of the application or use of any product, (ii) any and all liability, including without limitation special, consequential or incidental damages, and (iii) any and all implied warranties, including warranties of fitness for particular purpose, non-infringement and merchantability.

Statements regarding the suitability of products for certain types of applications are based on Vishay's knowledge of typical requirements that are often placed on Vishay products in generic applications. Such statements are not binding statements about the suitability of products for a particular application. It is the customer's responsibility to validate that a particular product with the properties described in the product specification is suitable for use in a particular application. Parameters provided in datasheets and / or specifications may vary in different applications and performance may vary over time. All operating parameters, including typical parameters, must be validated for each customer application by the customer's technical experts. Product specifications do not expand or otherwise modify Vishay's terms and conditions of purchase, including but not limited to the warranty expressed therein.

Except as expressly indicated in writing, Vishay products are not designed for use in medical, life-saving, or life-sustaining applications or for any other application in which the failure of the Vishay product could result in personal injury or death. Customers using or selling Vishay products not expressly indicated for use in such applications do so at their own risk. Please contact authorized Vishay personnel to obtain written terms and conditions regarding products designed for such applications.

No license, express or implied, by estoppel or otherwise, to any intellectual property rights is granted by this document or by any conduct of Vishay. Product names and markings noted herein may be trademarks of their respective owners.

X-ON Electronics

Largest Supplier of Electrical and Electronic Components

Click to view similar products for [Analog Switch ICs category](#):

Click to view products by [Vishay manufacturer](#):

Other Similar products are found below :

[PI5A100QEX](#) [DG9233EDY-GE3](#) [NLAS4684FCTCG](#) [NLAS5223BLMNR2G](#) [NLV74HC4066ADR2G](#) [MC74HC4067ADTG](#)
[NLX2G66DMUTCG](#) [NS5A4684SMNTAG](#) [732480R](#) [733995E](#) [425541DB](#) [425528R](#) [099044FB](#) [FSA221UMX](#) [MAX4888ETI+T](#)
[NLAS5123MNR2G](#) [NLAS7222AMTR2G](#) [MAX14807ECB+](#) [MAX4968ECM+](#) [PI5A4157CEX](#) [NLV14066BDG](#) [LC78615E-01US-H](#)
[PI5A4599BCEX](#) [PI5A3157BZUEX](#) [NLAS4717EPFCT1G](#) [PI5A3167CCEX](#) [MAX4744ELB+T](#) [MAX4802ACXZ+](#) [SLAS3158MNR2G](#)
[PI5A392AQE](#) [MAX4744HELB+T](#) [PI5A4157ZUEX](#) [MC74HC4067ADTR2G](#) [PI5A4158ZAEX](#) [PI5A3166TAEX](#) [MAX4901EBL+T](#)
[MAX14510EEVB+T](#) [PI3A3899ZTEX](#) [MAX4996ETG+T](#) [MAX4889AETO+T](#) [MAX14508EEVB+T](#) [MAX4701ETE+T](#) [MAX4996LETG+T](#)
[NLX2G66FCTAG](#) [TMUX136RSER](#) [HV2605FG-G](#) [DG302BDJ-E3](#) [ADG741BKSZ-REEL](#) [ADG742BKSZ5-REEL7](#) [PI5A100WE](#)