

16 Ω, Low Charge Injection and Leakage, +12 V / +5 V / +3 V / ± 5 V Quad SPST Switches

DESCRIPTION

The DG441LE, DG442LE monolithic quad single-pole-single-throw analog switches are designed to provide high speed, low error switching of analog signals. The DG441LE has a normally closed function. The DG442LE has a normally open function.

The DG441LE, DG442LE feature low charge injection of a few picocoulombs over the full analog switch range. Combining low on resistance (16 Ω, typ.), low parasitic capacitance ($C_{D(ON)}$ 15 pF), and fast switching speed (t_{ON} , 18 ns, typ.), the devices are ideal for data acquisition, sample-and-hold, and ADC input circuit designs.

The DG441LE, DG442LE operate on single and dual supplies. Single supply voltage ranges from 3 V to 16 V while dual supply operation is recommended with ± 3 V to ± 8 V. Each switch conducts equally well in both direction when on, and blocks input voltages up to the supply levels when off.

The DG441LE, DG442LE are available in 16 lead TSSOP, SOIC, and PDIP packages.

FEATURES

- 3 V to 16 V single supply or ± 3 V to ± 8 V dual supply
- On-resistance $R_{DS(on)}$: 16 Ω
- Fast switching t_{ON} : 18 ns, typ.
- Low parasitic capacitance:
 - $C_{D(ON)}$: 15 pF
 - $C_{S(OFF)}$: 5 pF
- Less than 8 pC charge injection over the full signal swing range
- Low leakage: < 10 pA, typ.
- TTL, CMOS compatible
- Material categorization: for definitions of compliance please see www.vishay.com/doc?99912

Note

* This datasheet provides information about parts that are RoHS-compliant and / or parts that are non-RoHS-compliant. For example, parts with lead (Pb) terminations are not RoHS-compliant. Please see the information / tables in this datasheet for details.



RoHS*
Available

HALOGEN
FREE
Available

BENEFITS

- Wide operation voltage range
- Low signal errors and distortion
- Fast switching time
- Minimized switching glitch

APPLICATIONS

- Automatic test equipment
- Process control and automation
- Data acquisition systems
- Meters and instruments
- Medical and healthcare systems
- Communication systems
- Audio and video signal routing
- Relay replacement
- Battery powered systems

FUNCTIONAL BLOCK DIAGRAM AND PIN CONFIGURATION

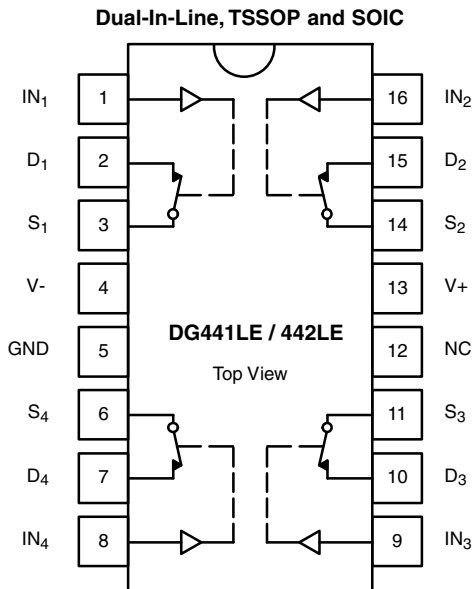

TRUTH TABLE

LOGIC	DG441LE	DG442LE
0	On	Off
1	Off	On

Logic "0" ≤ 0.8 V

Logic "1" ≥ 2.4 V



ORDERING INFORMATION				
TEMP. RANGE	CONFIGURATION	PACKAGE	PART NUMBER	MIN. ORDER / PACK. QUANTITY
-40 °C to +85 °C Lead (Pb)-free	DG441LE	16-pin TSSOP	DG441LEDQ-GE3	Tube 360 units
			DG441LEDQ-T1-GE3	Tape and reel, 3000 units
		16-pin SOIC	DG441LEDY-GE3	Tube 500 units
			DG441LEDY-T1-GE3	Tape and reel, 2500 units
		16-pin PDIP	DG441LEDJ-GE3	Tube 500 units
		DG442LE	16-pin TSSOP	DG442LEDQ-GE3
	DG442LEDQ-T1-GE3			Tape and reel, 3000 units
	16-pin SOIC		DG442LEDY-GE3	Tube 500 units
			DG442LEDY-T1-GE3	Tape and reel, 2500 units
	16-pin PDIP	DG442LEDJ-GE3	Tube 500 units	

ABSOLUTE MAXIMUM RATINGS (T _A = 25 °C, unless otherwise noted)			
PARAMETER	SYMBOL	LIMIT	UNIT
V ₊ to V ₋		-0.3 to +18	V
GND to V _{-A}		18	
Digital Inputs ^a V _S , V _D		GND -0.3 to (V ₊) + 0.3 or 30 mA, whichever occurs first	
Continuous Current (any terminal)		30	mA
Current, S or D (pulsed 1 ms, 10 % duty cycle)		100	
Storage Temperature	(DQ, DY suffix)	-65 to +125	°C
	(AK suffix)	-65 to +150	
Power Dissipation (packages) ^b	16-pin TSSOP ^c	450	mW
	16-pin narrow body SOIC ^d	650	
	16-pin CerDIP ^e	900	
ESD Human Body Model (HBM); per ANSI / ESDA / JEDEC [®] JS-001		2500	V
Latch Up Current, per JESD78D		400	mA

Notes

- Signals on S_x, D_x, or IN_x exceeding V₊ or V₋ will be clamped by internal diodes. Limit forward diode current to maximum current ratings.
- All leads welded or soldered to PC board.
- Derate 7 mW/°C above 75 °C.
- Derate 7.6 mW/°C above 75 °C.
- Derate 12 mW/°C above 75 °C.

Stresses beyond those listed under "Absolute Maximum Ratings" may cause permanent damage to the device. These are stress ratings only, and functional operation of the device at these or any other conditions beyond those indicated in the operational sections of the specifications is not implied. Exposure to absolute maximum rating conditions for extended periods may affect device reliability.



SPECIFICATIONS ^a (single supply 12 V)									
PARAMETER	SYMBOL	TEST CONDITIONS UNLESS OTHERWISE SPECIFIED $V_+ = 12\text{ V}, V_- = 0\text{ V}$ $V_{IN} = 2.4\text{ V}, 0.8\text{ V}^f$	TEMP. ^b	TYP. ^c	A SUFFIX LIMITS -55 °C to +125 °C		D SUFFIX LIMITS -40 °C to +85 °C		UNIT
					MIN. ^d	MAX. ^d	MIN. ^d	MAX. ^d	
Analog Switch									
Analog Signal Range ^e	V_{ANALOG}		Full	-	0	12	0	12	V
Drain-Source On-Resistance	$R_{DS(on)}$	$V_+ = 10.8\text{ V}, V_- = 0\text{ V}$ $I_S = 10\text{ mA}, V_D = 2\text{ V} / 9\text{ V}$	Room	16	-	26	-	26	Ω
			Full	-	-	40	-	35	
On-Resistance Match Between Channels ^e	$\Delta R_{DS(on)}$	$I_S = 10\text{ mA}, V_D = 9\text{ V}$	Room	0.1	-	0.5	-	0.5	
Switch Off Leakage Current	$I_{S(off)}$	$V_D = 1\text{ V} / 11\text{ V},$ $V_S = 11\text{ V} / 1\text{ V}$	Room	-	-1	1	-1	1	nA
			Full	-	-15	15	-10	10	
	Room		-	-1	1	-1	1		
	Full		-	-15	15	-10	10		
Channel On Leakage Current	$I_{D(on)}$	$V_S = V_D = 11\text{ V} / 1\text{ V}$	Room	-	-1	1	-1	1	
			Full	-	-15	15	-10	10	
Digital Control									
Input Current, V_{IN} Low	I_{IL}	V_{IN} under test = 0.8 V	Full	0.01	-1.5	1.5	-1	1	μA
Input Current, V_{IN} High	I_{IH}	V_{IN} under test = 2.4 V	Full	-	-1.5	1.5	-1	1	
Dynamic Characteristics									
Turn-On Time	t_{ON}	$R_L = 300\ \Omega, C_L = 35\text{ pF}$ $V_S = 5\text{ V},$ see figure 2	Room	18	-	60	-	60	ns
			Full	-	-	80	-	70	
Turn-Off Time	t_{OFF}		Room	18	-	35	-	35	
			Full	-	-	50	-	45	
Charge Injection ^e	Q	$V_g = 0\text{ V}, R_g = 0\ \Omega, C_L = 10\text{ nF}$	Room	6.6	-	-	-	-	pC
Off Isolation ^e	OIRR	$R_L = 50\ \Omega, C_L = 5\text{ pF},$ $f = 1\text{ MHz}$	Room	68.4	-	-	-	-	dB
Channel-to-Channel Crosstalk ^e	X_{TALK}		Room	114	-	-	-	-	
Source Off Capacitance ^e	$C_{S(off)}$	f = 1 MHz	Room	5	-	-	-	-	pF
Drain Off Capacitance ^e	$C_{D(off)}$		Room	6	-	-	-	-	
Channel On Capacitance ^e	$C_{D(on)}$		Room	15	-	-	-	-	
Power Supplies									
Positive Supply Current	I +	$V_{IN} = 0\text{ V or }12\text{ V}$	Full	0.03	-	1.5	-	1	μA
Negative Supply Current	I -		Room	-	-1	-	-1	-	
			Full	0.002	-7.5	-	-5	-	
Ground Current	I_{GND}		Full	0.002	-1.5	-	-1	-	



SPECIFICATIONS ^a (dual supply ± 5 V)									
PARAMETER	SYMBOL	TEST CONDITIONS UNLESS OTHERWISE SPECIFIED $V_+ = 5$ V, $V_- = -5$ V $V_{IN} = 2.4$ V, 0.8 V ^f	TEMP. ^b	TYP. ^c	A SUFFIX LIMITS -55 °C to +125 °C		D SUFFIX LIMITS -40 °C to +85 °C		UNIT
					MIN. ^d	MAX. ^d	MIN. ^d	MAX. ^d	
Analog Switch									
Analog Signal Range ^e	V_{ANALOG}		Full	-	-5	5	-5	5	V
Drain-Source On-Resistance	$R_{DS(on)}$	$V_+ = 5$ V, $V_- = -5$ V $I_S = 10$ mA, $V_D = \pm 3.5$ V	Room	18	-	30	-	30	Ω
			Full	-	-	42	-	37	
On-Resistance Match Between Channels ^e	$\Delta R_{DS(on)}$	$I_S = 10$ mA, $V_D = \pm 3.5$ V	Room	0.1	-	0.5	-	0.5	
Switch Off Leakage Current ^g	$I_{S(off)}$	$V_+ = 5.5$, $V_- = -5.5$ V $V_D = \pm 4.5$ V, $V_S = \pm 4.5$ V	Room	-	-1	1	-1	1	nA
			Full	-	-15	15	-10	10	
	Room		-	-1	1	-1	1		
	Full		-	-15	15	-10	10		
Channel On Leakage Current ^g	$I_{D(on)}$	$V_+ = 5.5$ V, $V_- = -5.5$ V $V_S = V_D = \pm 4.5$ V	Room	-	-1	1	-1	1	
			Full	-	-15	15	-10	10	
Digital Control									
Input Current, V_{IN} Low ^e	I_{IL}	V_{IN} under test = 0.8 V	Full	0.05	-1.5	1.5	-1	1	μ A
Input Current, V_{IN} High ^e	I_{IH}	V_{IN} under test = 2.4 V	Full	0.05	-1.5	1.5	-1	1	
Dynamic Characteristics									
Turn-On Time	t_{ON}	$R_L = 300 \Omega$, $C_L = 35$ pF $V_S = \pm 3.5$ V, see figure 2	Room	42	-	65	-	65	ns
			Full	-	-	90	-	75	
Turn-Off Time	t_{OFF}		Room	34	-	45	-	45	
			Full	-	-	65	-	55	
Charge Injection ^e	Q	$V_g = 0$ V, $R_g = 0 \Omega$, $C_L = 10$ nF	Room	5.8	-	-	-	-	pC
Off Isolation ^e	OIRR	$R_L = 50 \Omega$, $C_L = 5$ pF, $f = 1$ MHz	Room	68.4	-	-	-	-	dB
Channel-to-Channel Crosstalk ^e	X_{TALK}		Room	113	-	-	-	-	
Source Off Capacitance ^e	$C_{S(off)}$	$f = 1$ MHz	Room	5	-	-	-	-	pF
Drain Off Capacitance ^e	$C_{D(off)}$		Room	6	-	-	-	-	
Channel On Capacitance ^e	$C_{D(on)}$		Room	14	-	-	-	-	
Power Supplies									
Positive Supply Current ^e	I +	$V_{IN} = 0$ V or 5 V	Full	0.002	-	1.5	-	1	μ A
Negative Supply Current ^e	I -		Room	-0.002	-1	-	-1	-	
			Full	-	-7.5	-	-5	-	
Ground Current ^e	I_{GND}		Full	-0.002	-1.5	-	-1	-	



SPECIFICATIONS ^a (single supply ± 5 V)									
PARAMETER	SYMBOL	TEST CONDITIONS UNLESS OTHERWISE SPECIFIED $V_+ = 5$ V, $V_- = 0$ V $V_{IN} = 2.4$ V, 0.8 V ^f	TEMP. ^b	TYP. ^c	A SUFFIX LIMITS -55 °C to +125 °C		D SUFFIX LIMITS -40 °C to +85 °C		UNIT
					MIN. ^d	MAX. ^d	MIN. ^d	MAX. ^d	
Analog Switch									
Analog Signal Range ^e	V_{ANALOG}		Full	-	-	5	-	5	V
Drain-Source On-Resistance ^e	$R_{DS(on)}$	$V_+ = 4.5$ V $I_S = 5$ mA, $V_D = 1$ V, 3.5 V	Room	36	-	50	-	50	Ω
			Full	-	-	88	-	75	
On-Resistance Match Between Channels ^e	$\Delta R_{DS(on)}$	$I_S = 10$ mA, $V_D = 3.5$ V	Room	0.5	-	1	-	1	
Dynamic Characteristics									
Turn-On Time ^e	t_{ON}	$R_L = 300$ Ω , $C_L = 35$ pF $V_S = 3.5$ V, see figure 2	Room	53	-	70	-	70	ns
			Hot	-	-	90	-	80	
Turn-Off Time ^e	t_{OFF}		Room	34	-	50	-	50	
			Hot	-	-	70	-	60	
Charge Injection ^e	Q	$V_g = 0$ V, $R_g = 0$ Ω , $C_L = 10$ nF	Room	3.3	-	-	-	-	pC
Power Supplies									
Positive Supply Current ^e	I +	$V_{IN} = 0$ V or 5 V	Full	10	-	200	-	100	μ A
Negative Supply Current ^e	I -		Room	-0.002	-1	-	-1	-	
			Full	-	-7.5	-	-5	-	
Ground Current ^e	I_{GND}		Full	-10	-200	-	-100	-	



SPECIFICATIONS ^a (single supply 3 V)									
PARAMETER	SYMBOL	TEST CONDITIONS UNLESS OTHERWISE SPECIFIED $V_+ = 3\text{ V}, V_- = 0\text{ V}$ $V_{IN} = 0.4\text{ V}^f$	TEMP. ^b	TYP. ^c	A SUFFIX LIMITS -55 °C to +125 °C		D SUFFIX LIMITS -40 °C to +85 °C		UNIT
					MIN. ^d	MAX. ^d	MIN. ^d	MAX. ^d	
Analog Switch									
Analog Signal Range ^e	V_{ANALOG}		Full	-	0	3	0	3	V
Drain-Source On-Resistance	$R_{DS(on)}$	$V_+ = 2.7\text{ V}, V_- = 0\text{ V}$ $I_S = 5\text{ mA}, V_D = 0.5\text{ V}, 2.2\text{ V}$	Room	106	-	130	-	130	Ω
			Full	-	-	150	-	140	
On-Resistance Match Between Channels ^e	$\Delta R_{DS(on)}$	$I_S = 5\text{ mA}, V_D = 2.2\text{ V}$	Room	1	-	3	-	3	
Switch Off Leakage Current ^g	$I_{S(off)}$	$V_+ = 3.3, V_- = 0\text{ V}$ $V_D = 1\text{ V}, 2\text{ V}, V_S = 2\text{ V}, 1\text{ V}$	Room	-	-1	1	-1	1	nA
			Full	-	-15	15	-10	10	
	Room		-	-1	1	-1	1		
	Full		-	-15	15	-10	10		
Channel On Leakage Current ^g	$I_{D(on)}$	$V_+ = 3.3\text{ V}, V_- = 0\text{ V}$ $V_S = V_D = 1\text{ V}, 2\text{ V}$	Room	-	-1	1	-1	1	
			Full	-	-15	15	-10	10	
Digital Control									
Input Current, V_{IN} Low ^e	I_{IL}	V_{IN} under test = 0.4 V	Full	0.005	-1.5	1.5	-1	1	μA
Input Current, V_{IN} High ^e	I_{IH}	V_{IN} under test = 2.4 V	Full	0.005	-1.5	1.5	-1	1	
Dynamic Characteristics									
Turn-On Time	t_{ON}	$R_L = 300\ \Omega, C_L = 35\text{ pF}$ $V_S = 1.5\text{ V},$ see figure 2	Room	141	-	200	-	200	ns
			Full	-	-	220	-	210	
Turn-Off Time	t_{OFF}		Room	84	-	120	-	120	
			Full	-	-	140	-	130	
Charge Injection ^e	Q	$V_g = 0\text{ V}, R_g = 0\ \Omega, C_L = 10\text{ nF}$	Room	2	-	-	-	-	pC
Off Isolation ^e	OIRR		Room	68	-	-	-	-	
Channel-to-Channel Crosstalk ^e	X_{TALK}	$R_L = 50\ \Omega, C_L = 5\text{ pF}, f = 1\text{ MHz}$	Room	107	-	-	-	-	dB
Source Off Capacitance ^e	$C_{S(off)}$	f = 1 MHz	Room	6	-	-	-	-	pF
Drain Off Capacitance ^e	$C_{D(off)}$		Room	7	-	-	-	-	
Channel On Capacitance ^e	$C_{D(on)}$		Room	15	-	-	-	-	

Notes

- a. Refer to PROCESS OPTION FLOWCHART.
- b. Room = 25 °C, full = as determined by the operating temperature suffix.
- c. Typical values are for DESIGN AID ONLY, not guaranteed nor subject to production testing.
- d. The algebraic convention whereby the most negative value is a minimum and the most positive a maximum, is used in this datasheet.
- e. Guaranteed by design, not subject to production test.
- f. V_{IN} = input voltage to perform proper function.
- g. Leakage parameters are guaranteed by worst case test conditions and not subject to test.



TYPICAL CHARACTERISTICS (25 °C, unless otherwise noted)



R_{DS(on)} vs. Analog Voltage and Temperature



R_{DS(on)} vs. Drain Voltage and Temperature



R_{DS(on)} vs. Analog Voltage

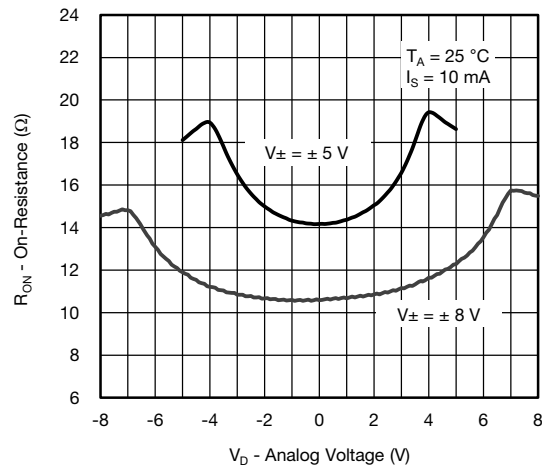

R_{DS(on)} vs. Analog Voltage



Leakage Current vs. Drain Voltage (Dual Supply)



TYPICAL CHARACTERISTICS (25 °C, unless otherwise noted)



Switching Time vs. Single Supply



Switching Time vs. Dual Supply

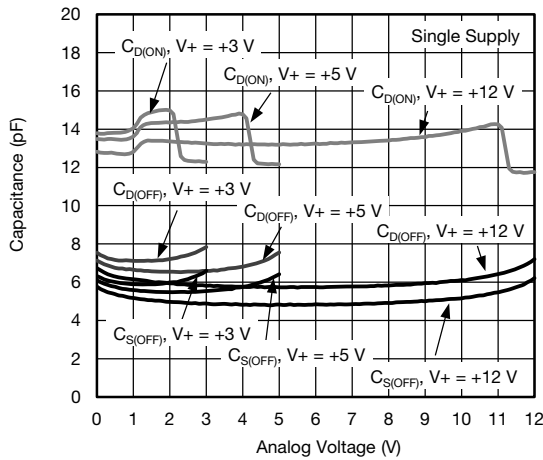

Capacitance vs. Analog Voltage (Single Supply)

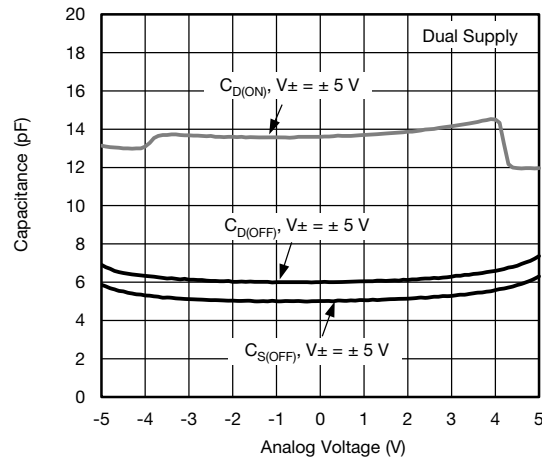

Capacitance vs. Analog Voltage (Dual Supply)



R_{DS(on)} vs. Analog Voltage and Temperature



TYPICAL CHARACTERISTICS (25 °C, unless otherwise noted)



Input Threshold vs. Single Supply Voltage



Insertion Loss, Off Isolation and Crosstalk vs. Frequency (Single Supply)



Charge Injection vs. Analog Voltage



Supply Current vs. Temperature

SCHEMATIC DIAGRAM (typical channel)

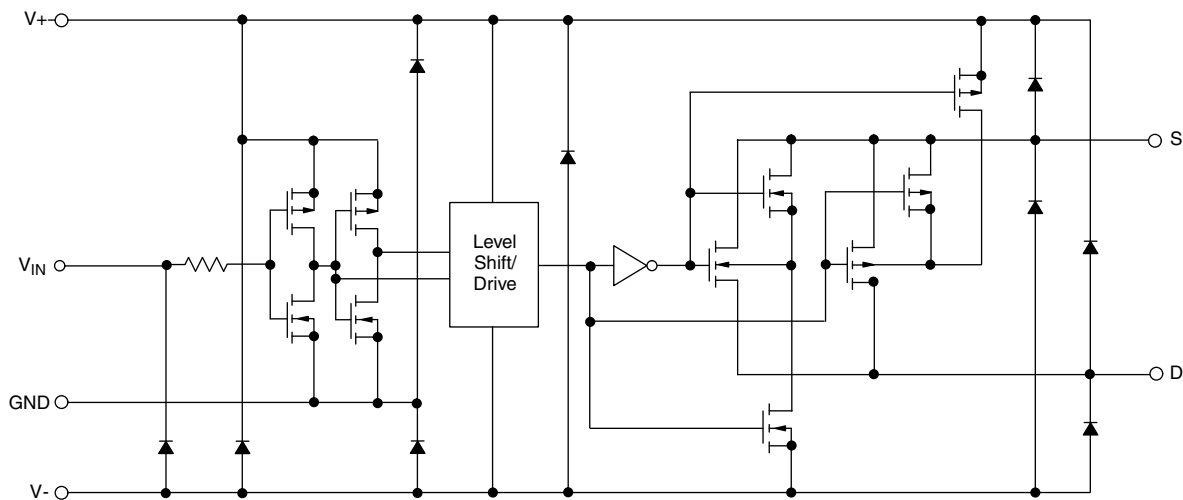
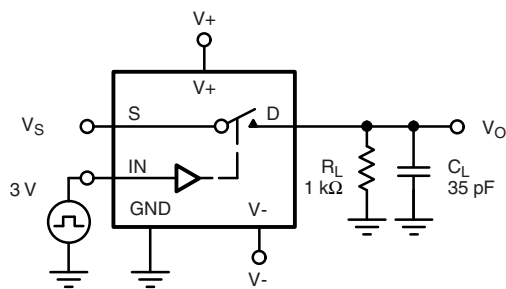
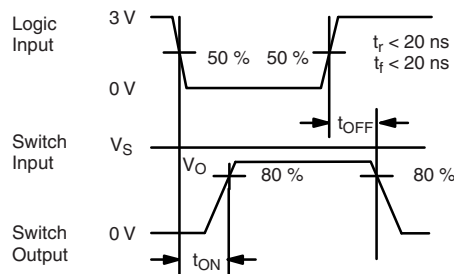

Fig. 1

TEST CIRCUITS



C_L (includes fixture and stray capacitance)



Note: Logic input waveform is inverted for DG442.

Fig. 2 - Switching Time

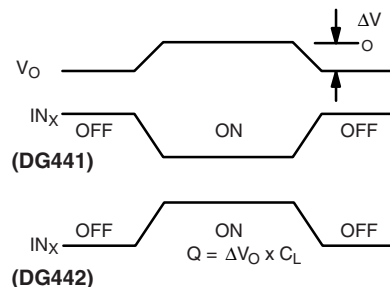
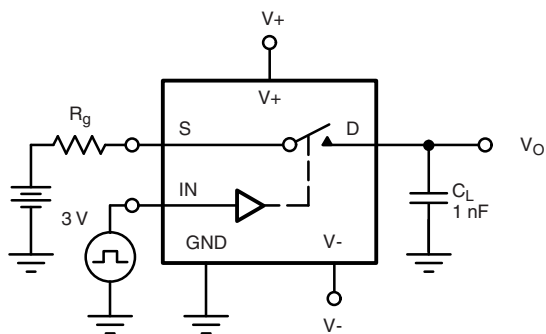

Fig. 3 - Charge Injection

TEST CIRCUITS



Fig. 4 - Crosstalk



Fig. 5 - Off Isolation

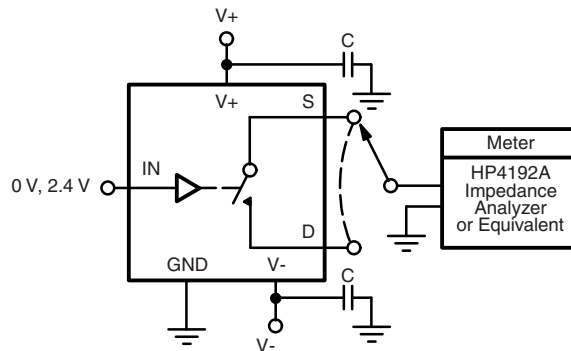

Fig. 6 - Source / Drain Capacitances

APPLICATIONS



Fig. 7 - Power MOSFET Driver



Fig. 8 - Open Loop Sample-and-Hold



Gain error is determined only by the resistor tolerance. Op amp offset and CMRR will limit accuracy of circuit.

With SW₄ Closed

$$\frac{V_{OUT}}{V_{IN}} = \frac{R_1 + R_2 + R_3 + R_4}{R_4} = 100$$

Fig. 9 - Precision-Weighted Resistor Programmable-Gain Amplifier

Vishay Siliconix maintains worldwide manufacturing capability. Products may be manufactured at one of several qualified locations. Reliability data for Silicon Technology and Package Reliability represent a composite of all qualified locations. For related documents such as package/tape drawings, part marking, and reliability data, see www.vishay.com/ppg?76754.



SOIC (NARROW): 16-LEAD
JEDEC Part Number: MS-012



Dim	MILLIMETERS		INCHES	
	Min	Max	Min	Max
A	1.35	1.75	0.053	0.069
A ₁	0.10	0.20	0.004	0.008
B	0.38	0.51	0.015	0.020
C	0.18	0.23	0.007	0.009
D	9.80	10.00	0.385	0.393
E	3.80	4.00	0.149	0.157
e	1.27 BSC		0.050 BSC	
H	5.80	6.20	0.228	0.244
L	0.50	0.93	0.020	0.037
∅	0°	8°	0°	8°

ECN: S-03946—Rev. F, 09-Jul-01
DWG: 5300



PDIP: 16-LEAD



Dim	MILLIMETERS		INCHES	
	Min	Max	Min	Max
A	3.81	5.08	0.150	0.200
A₁	0.38	1.27	0.015	0.050
B	0.38	0.51	0.015	0.020
B₁	0.89	1.65	0.035	0.065
C	0.20	0.30	0.008	0.012
D	18.93	21.33	0.745	0.840
E	7.62	8.26	0.300	0.325
E₁	5.59	7.11	0.220	0.280
e₁	2.29	2.79	0.090	0.110
e_A	7.37	7.87	0.290	0.310
L	2.79	3.81	0.110	0.150
Q₁	1.27	2.03	0.050	0.080
S	0.38	1.52	.015	0.060

ECN: S-03946—Rev. D, 09-Jul-01
DWG: 5482

TSSOP: 16-LEAD

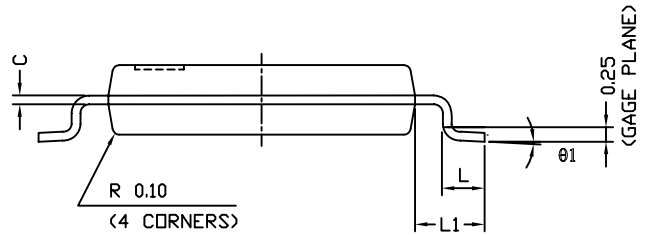
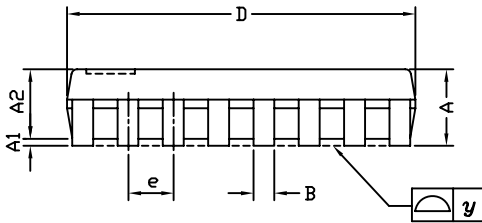
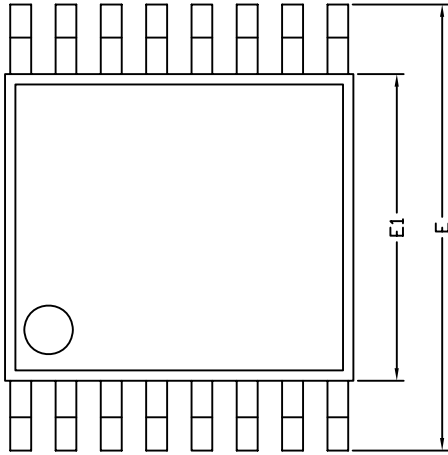

Symbols	DIMENSIONS IN MILLIMETERS		
	Min	Nom	Max
A	-	1.10	1.20
A1	0.05	0.10	0.15
A2	-	1.00	1.05
B	0.22	0.28	0.38
C	-	0.127	-
D	4.90	5.00	5.10
E	6.10	6.40	6.70
E1	4.30	4.40	4.50
e	-	0.65	-
L	0.50	0.60	0.70
L1	0.90	1.00	1.10
y	-	-	0.10
theta1	0°	3°	6°

ECN: S-61920-Rev. D, 23-Oct-06
DWG: 5624



RECOMMENDED MINIMUM PAD FOR TSSOP-16



Recommended Minimum Pads
Dimensions in inches (mm)

RECOMMENDED MINIMUM PADS FOR SO-16



Recommended Minimum Pads
Dimensions in Inches/(mm)

[Return to Index](#)



Disclaimer

ALL PRODUCT, PRODUCT SPECIFICATIONS AND DATA ARE SUBJECT TO CHANGE WITHOUT NOTICE TO IMPROVE RELIABILITY, FUNCTION OR DESIGN OR OTHERWISE.

Vishay Intertechnology, Inc., its affiliates, agents, and employees, and all persons acting on its or their behalf (collectively, "Vishay"), disclaim any and all liability for any errors, inaccuracies or incompleteness contained in any datasheet or in any other disclosure relating to any product.

Vishay makes no warranty, representation or guarantee regarding the suitability of the products for any particular purpose or the continuing production of any product. To the maximum extent permitted by applicable law, Vishay disclaims (i) any and all liability arising out of the application or use of any product, (ii) any and all liability, including without limitation special, consequential or incidental damages, and (iii) any and all implied warranties, including warranties of fitness for particular purpose, non-infringement and merchantability.

Statements regarding the suitability of products for certain types of applications are based on Vishay's knowledge of typical requirements that are often placed on Vishay products in generic applications. Such statements are not binding statements about the suitability of products for a particular application. It is the customer's responsibility to validate that a particular product with the properties described in the product specification is suitable for use in a particular application. Parameters provided in datasheets and/or specifications may vary in different applications and performance may vary over time. All operating parameters, including typical parameters, must be validated for each customer application by the customer's technical experts. Product specifications do not expand or otherwise modify Vishay's terms and conditions of purchase, including but not limited to the warranty expressed therein.

Except as expressly indicated in writing, Vishay products are not designed for use in medical, life-saving, or life-sustaining applications or for any other application in which the failure of the Vishay product could result in personal injury or death. Customers using or selling Vishay products not expressly indicated for use in such applications do so at their own risk. Please contact authorized Vishay personnel to obtain written terms and conditions regarding products designed for such applications.

No license, express or implied, by estoppel or otherwise, to any intellectual property rights is granted by this document or by any conduct of Vishay. Product names and markings noted herein may be trademarks of their respective owners.

Material Category Policy

Vishay Intertechnology, Inc. hereby certifies that all its products that are identified as RoHS-Compliant fulfill the definitions and restrictions defined under Directive 2011/65/EU of The European Parliament and of the Council of June 8, 2011 on the restriction of the use of certain hazardous substances in electrical and electronic equipment (EEE) - recast, unless otherwise specified as non-compliant.

Please note that some Vishay documentation may still make reference to RoHS Directive 2002/95/EC. We confirm that all the products identified as being compliant to Directive 2002/95/EC conform to Directive 2011/65/EU.

Vishay Intertechnology, Inc. hereby certifies that all its products that are identified as Halogen-Free follow Halogen-Free requirements as per JEDEC JS709A standards. Please note that some Vishay documentation may still make reference to the IEC 61249-2-21 definition. We confirm that all the products identified as being compliant to IEC 61249-2-21 conform to JEDEC JS709A standards.

X-ON Electronics

Largest Supplier of Electrical and Electronic Components

Click to view similar products for [Analogue Switch ICs category](#):

Click to view products by [Vishay manufacturer](#):

Other Similar products are found below :

[FSA3051TMX](#) [NLAS4684FCTCG](#) [NLAS5223BLMNR2G](#) [NLVAS4599DTT1G](#) [NLX2G66DMUTCG](#) [425541DB](#) [425528R](#) [099044FB](#)
[NLAS5123MNR2G](#) [PI5A4157CEX](#) [PI5A4599BCEX](#) [NLAS4717EPFCT1G](#) [PI5A3167CCEX](#) [SLAS3158MNR2G](#) [PI5A392AQE](#)
[PI5A4157ZUEX](#) [PI5A3166TAEX](#) [FSA634UCX](#) [TC4066BP\(N,F\)](#) [DG302BDJ-E3](#) [PI5A100QEX](#) [HV2605FG-G](#) [HV2301FG-G](#)
[RS2117YUTQK10](#) [RS2118YUTQK10](#) [RS2227XUTQK10](#) [ADG452BRZ-REEL7](#) [MAX4066ESD+](#) [MAX391CPE+](#) [MAX4730EXT+T](#)
[MAX314CPE+](#) [BU4066BCFV-E2](#) [MAX313CPE+](#) [BU4S66G2-TR](#) [NLASB3157MTR2G](#) [TS3A4751PWR](#) [NLAST4599DFT2G](#)
[NLAST4599DTT1G](#) [DG300BDJ-E3](#) [DG2503DB-T2-GE1](#) [TC4W53FU\(TE12L,F\)](#) [74HC2G66DC.125](#) [ADG619BRMZ-REEL](#) [DG2535EDQ-](#)
[T1-GE3](#) [LTC201ACN#PBF](#) [74LV4066DB,118](#) [FSA2275AUMX](#) [DIO1500WL12](#) [ADG742BKSZ-REEL7](#) [DIO1269LP10](#)