

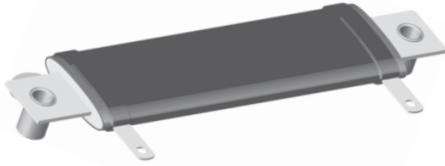

## Wirewound Resistors, Industrial Power, Flat



### FEATURES

- High temperature silicon coating
- Mounting accommodations ideally suited to high density packaging
- Self-stacking hardware for horizontal or vertical placement
- Withstands high vibrations without loosening
- Mounting hardware functions as a heat sink allowing greater heat dissipation and less derating of stacked units
- Material categorization: for definitions of compliance please see [www.vishay.com/doc?99912](http://www.vishay.com/doc?99912)



**RoHS**  
COMPLIANT  
HALOGEN  
**FREE**  
**GREEN**  
(5-2008)

STANDARD ELECTRICAL SPECIFICATIONS					
GLOBAL MODEL	HISTORICAL MODEL	POWER RATING $P_{25^{\circ}\text{C}}$ W	RESISTANCE RANGE $\Omega$ $\pm 5\%$	RESISTANCE RANGE $\Omega$ $\pm 10\%$	WEIGHT (typical) g
FSOT10 FSOT10-NI	FSOT-10 FSOT-10-NI	10	1.0 to 15K 1.0 to 1.8K	0.10 to 15K 1.0 to 1.8K	0.41
FSOT15 FSOT15-NI	FSOT-15 FSOT-15-NI	15	1.0 to 26K 1.0 to 3.6K	0.10 to 26K 1.0 to 3.6K	0.47
FSOT20 FSOT20-NI	FSOT-20 FSOT-20-NI	20	1.0 to 71K 1.0 to 9.8K	0.10 to 71K 1.0 to 9.8K	0.74
FSOT30...14 / FSOT30...16 FSOT30...15 / FSOT30...17	HL-24-09 / HL-24-16 NHL-24-09 / NHL-24-16	30	1.0 to 11K 1.0 to 1.2K	0.10 to 11K 1.0 to 1.2K	20.14
FSOT40...14 / FSOT40...16 FSOT40...15 / FSOT40...17	HL-40-09 / HL-40-16 NHL-40-09 / NHL-40-16	40	1.0 to 26K 1.0 to 3K	0.10 to 26K 1.0 to 3K	30.07
FSOT55...14 / FSOT55...16 FSOT55...15 / FSOT55...17	HL-55-09 / HL-55-16 NHL-55-09 / NHL-55-16	55	1.0 to 54K 1.0 to 6.8K	0.10 to 54K 1.0 to 6.8K	51.25
FSOT70...14 / FSOT70...16 FSOT70...15 / FSOT70...17	HL-70-09 / HL-70-16 NHL-70-09 / NHL-70-16	70	1.0 to 77K 1.0 to 9.4K	0.10 to 77K 1.0 to 9.4K	60.48
FSOT95...14 / FSOT95...16 FSOT95...15 / FSOT95...17	HL-95-09 / HL-95-16 NHL-95-09 / NHL-95-16	95	1.0 to 99.9K 1.0 to 12.4K	0.10 to 99.9K 1.0 to 12.4K	76.51

TECHNICAL SPECIFICATIONS		
PARAMETER	UNIT	FSOT, FSOT...XX FLAT RESISTOR CHARACTERISTICS
Temperature coefficient	ppm/ $^{\circ}\text{C}$	$\pm 90$ for 0.1 $\Omega$ to 0.99 $\Omega$ ; $\pm 50$ for 1 $\Omega$ to 9.9 $\Omega$ ; $\pm 30$ for 10 $\Omega$ and above
Dielectric withstanding voltage	$V_{AC}$	1000, from terminal to mounting hardware
Short time overload	-	10 x rated power for 5 s
Maximum working voltage	V	$(P \times R)^{1/2}$
Insulation resistance	$\Omega$	1000 M $\Omega$ minimum dry, 100 M $\Omega$ minimum after moisture test
Operating temperature range	$^{\circ}\text{C}$	-55 to +350

**GLOBAL PART NUMBER INFORMATION**

 Global Part Numbering Example: **FSOT3009E10R00JE14**

<b>F</b>	<b>S</b>	<b>O</b>	<b>T</b>	<b>3</b>	<b>0</b>	<b>0</b>	<b>9</b>	<b>E</b>	<b>1</b>	<b>0</b>	<b>R</b>	<b>0</b>	<b>0</b>	<b>J</b>	<b>E</b>	<b>1</b>	<b>4</b>
----------	----------	----------	----------	----------	----------	----------	----------	----------	----------	----------	----------	----------	----------	----------	----------	----------	----------

GLOBAL MODEL (6 digits)	TERMINAL DESIGNATION (2 digits)	TERMINAL FINISH (1 digit)	RESISTANCE VALUE (5 digits)	TOLERANCE	PACKAGING CODE	SPECIAL
<b>FSOT30</b> (see "Standard Electrical Specifications" table above for additional P/N's)	<b>09</b> <b>16</b> <b>11 (only FSOT10, FSOT15, FSOT20)</b>	<b>E</b> = lead (Pb)-free	<b>R</b> = decimal <b>K</b> = thousand <b>10R00</b> = 10.0 Ω <b>1K500</b> = 1.5 kΩ	<b>J</b> = ± 5.0 % <b>K</b> = ± 10.0 %	<b>E</b> = lead (Pb)-free cell and bulk pack	(dash number) (up to 2 digits) From <b>1 to 99</b> as applicable; leave empty if 11 terminal <b>NI</b> = non-inductive (11 terminal only) <b>14</b> = standard, 09 terminal <b>15</b> = non-inductive, 09 terminal <b>16</b> = standard, 16 terminal <b>17</b> = non-inductive, 16 terminal

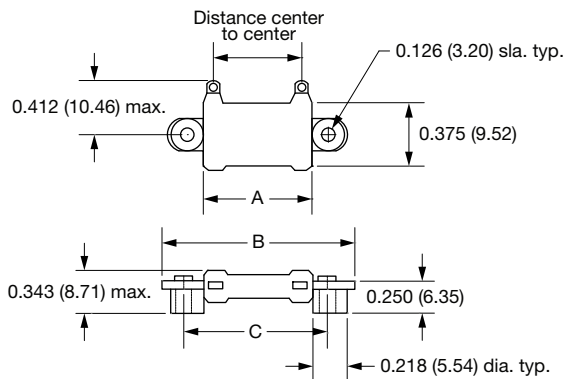
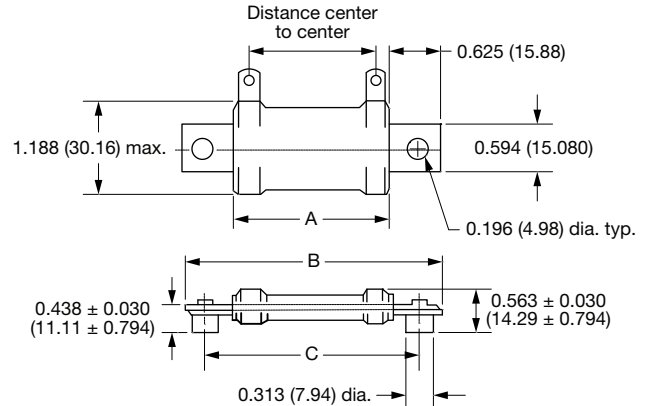
**DIMENSIONS in inches [millimeters]**
**FSOT10 / FSOT15 / FSOT20**

**FSOT...XX FLAT 30 / 40 / 55 / 70 / 95**

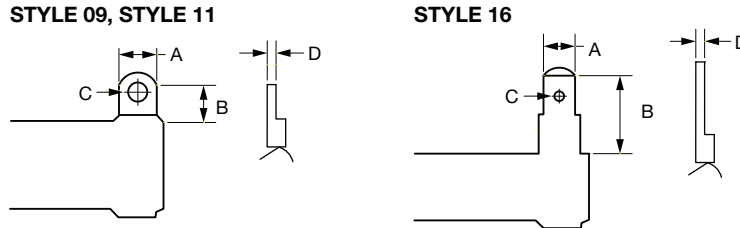
MODEL	A ± 0.063 [1.59]	B ± 0.063 [1.59]	C ± 0.031 [0.79]	DISTANCE CENTER TO CENTER (ref.)	TERMINAL DESIGNATION	
					STANDARD	OPTIONAL
<b>FSOT10</b>	0.750 [19.05]	1.3125 [33.34]	1.000 [25.40]	0.531 [13.49]	11E	-
<b>FSOT15</b>	1.000 [25.40]	1.5625 [39.69]	1.250 [31.75]	0.781 [19.84]	11E	-
<b>FSOT20</b>	2.062 [52.37]	2.625 [66.68]	2.313 [58.75]	1.843 [46.81]	11E	-
<b>FSOT30...XX</b>	1.250 [31.75]	2.500 [63.50]	2.000 [50.80]	0.718 [18.24]	09E	16E
<b>FSOT40...XX</b>	2.000 [50.80]	3.250 [82.55]	2.750 [69.85]	1.468 [37.29]	09E	16E
<b>FSOT55...XX</b>	3.500 [88.90]	4.750 [120.65]	4.250 [107.95]	2.968 [75.39]	09E	16E
<b>FSOT70...XX</b>	4.750 [120.65]	6.000 [152.40]	5.500 [139.70]	4.218 [107.14]	09E	16E
<b>FSOT95...XX</b>	6.000 [152.40]	7.250 [184.15]	6.750 [171.45]	5.468 [138.89]	09E	16E

**TERMINAL DIMENSIONS** in inches [millimeters]

DIMENSION	STYLE 09	STYLE 11	STYLE 16
A	0.188 [4.78]	0.125 [3.18]	0.188 [4.76]
B	0.458 [11.63]	0.255 [6.48]	0.563 [14.29]
C	0.104 [2.64]	0.081 [2.06]	0.050 [1.27]
D	0.020 [0.51]	0.020 [0.51]	0.020 [0.51]

**POWER RATING**

Vishay FSOT flat resistor wattage ratings are based on mounting horizontally to 10" x 10" x 0.04" [254.0 mm x 254.0 mm x 1.02 mm] steel plate in 25 °C ambient with no air flow.

**EXCLUSIVE BRACKET DESIGN**

Mounting strap fits snugly through resistor core and is bound against unit by two eccentric spacers. The bracket eliminates expensive cements and improves heat transfer and power handling capabilities.

**MATERIAL SPECIFICATIONS**

**Element:** copper-nickel alloy of nickel-chrome alloy, depending on resistance value

**Core:** ceramic, steatite

**Coating:** special high temperature silicone

**Standard Terminals:** model "E" terminals are tinned steel

**Terminal Bands:** steel

**Part Marking:** HEI, model, wattage, value, tolerance, date code

**TERMINAL FINISH**

"E" finish - 100 % Sn coated steel.

**NON-INDUCTIVE**

Models of equivalent physical and electrical specifications are available with non-inductive (Aryton-Perry) winding. For non-inductive models, maximum resistance values are lower, see Standard Electrical Specifications table.

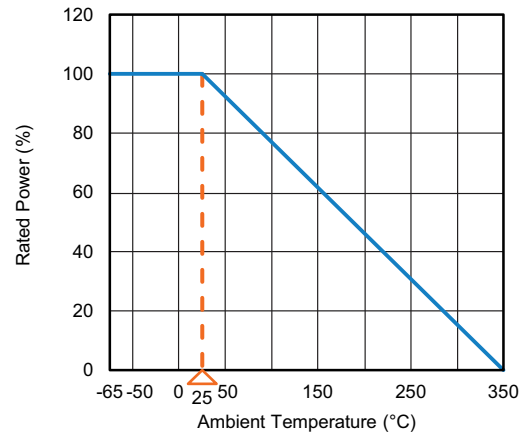
**DERATING**

Derating is required for ambient temperatures above 25 °C per the above graph.

PERFORMANCE		
TEST	CONDITIONS OF TEST	TEST LIMITS
Thermal shock	Rated power applied until thermally stable, then a minimum of 15 min at -55 °C	± (2.0 % + 0.05 Ω) ΔR
Short time overload	10 x rated power for 5 s	± (2.0 % + 0.05 Ω) ΔR
Dielectric withstanding voltage	1000 V <sub>RMS</sub> , 1 min	± (0.1 % + 0.05 Ω) ΔR
Low temperature storage	-55 °C for 24 h	± (2.0 % + 0.05 Ω) ΔR
High temperature exposure	250 h at +350 °C	± (2.0 % + 0.05 Ω) ΔR
Moisture resistance	MIL-STD-202 method 106, 7b not applicable	± (2.0 % + 0.05 Ω) ΔR
Shock, specified pulse	MIL-STD-202 method 213, 100 g's for 6 ms, 10 shocks	± (0.2 % + 0.05 Ω) ΔR
Vibration, high frequency	Frequency varied 10 Hz to 2000 Hz, 20 g peak, 2 directions 6 h each	± (0.2 % + 0.05 Ω) ΔR
Load life	1000 h at rated power, +25 °C, 1.5 h "ON", 0.5 h "OFF"	± (3.0 % + 0.05 Ω) ΔR



## **Disclaimer**

ALL PRODUCT, PRODUCT SPECIFICATIONS AND DATA ARE SUBJECT TO CHANGE WITHOUT NOTICE TO IMPROVE RELIABILITY, FUNCTION OR DESIGN OR OTHERWISE.

Vishay Intertechnology, Inc., its affiliates, agents, and employees, and all persons acting on its or their behalf (collectively, "Vishay"), disclaim any and all liability for any errors, inaccuracies or incompleteness contained in any datasheet or in any other disclosure relating to any product.

Vishay makes no warranty, representation or guarantee regarding the suitability of the products for any particular purpose or the continuing production of any product. To the maximum extent permitted by applicable law, Vishay disclaims (i) any and all liability arising out of the application or use of any product, (ii) any and all liability, including without limitation special, consequential or incidental damages, and (iii) any and all implied warranties, including warranties of fitness for particular purpose, non-infringement and merchantability.

Statements regarding the suitability of products for certain types of applications are based on Vishay's knowledge of typical requirements that are often placed on Vishay products in generic applications. Such statements are not binding statements about the suitability of products for a particular application. It is the customer's responsibility to validate that a particular product with the properties described in the product specification is suitable for use in a particular application. Parameters provided in datasheets and / or specifications may vary in different applications and performance may vary over time. All operating parameters, including typical parameters, must be validated for each customer application by the customer's technical experts. Product specifications do not expand or otherwise modify Vishay's terms and conditions of purchase, including but not limited to the warranty expressed therein.

Except as expressly indicated in writing, Vishay products are not designed for use in medical, life-saving, or life-sustaining applications or for any other application in which the failure of the Vishay product could result in personal injury or death. Customers using or selling Vishay products not expressly indicated for use in such applications do so at their own risk. Please contact authorized Vishay personnel to obtain written terms and conditions regarding products designed for such applications.

No license, express or implied, by estoppel or otherwise, to any intellectual property rights is granted by this document or by any conduct of Vishay. Product names and markings noted herein may be trademarks of their respective owners.

## X-ON Electronics

Largest Supplier of Electrical and Electronic Components

*Click to view similar products for [Wirewound Resistors - Through Hole category](#):*

*Click to view products by [Vishay manufacturer](#):*

Other Similar products are found below :

[75822-2K4](#) [90J56R](#) [AC03000001208JAC00](#) [EP3WS47RJ](#) [C1010KJL](#) [C1015RJL](#) [C3A10KJT](#) [27J1K0](#) [ES3W47RJ](#) [AC04000001500JAC00](#)  
[AC10000002208JAB00](#) [AC10000004708JAB00](#) [SQMW5R39J](#) [SQPW5R22J](#) [SQPW5R33J](#) [1879927-3](#) [FCB2100RJ](#) [T505](#) [FSQ5WR47J](#)  
[FW10A33R0JA](#) [C1010RJL](#) [C10220RJL](#) [C10R47JL](#) [C141K0JL](#) [C144R7JL](#) [ES05W100RJ](#) [SQMW1047RJ](#) [SQMW210RJ](#) [ULW5-39R0JT075](#)  
[ULW5-68RJT075](#) [SQBW401K0JFASTON](#) [SPH1001JLF](#) [65888-3R3](#) [SQP500JB-400R](#) [SQBW403R3JFASTON](#) [280-PRM7-4.7-RC](#)  
[CW02B9R100JE73](#) [FW70A1000JA](#) [AC05000005608JAC00](#) [SQPW547RJ](#) [SQMW10R68J](#) [C102K2JL](#) [SQPW510RJ](#) [PW103001KLF](#)  
[SQPW522RJ](#) [SQPW568RJ](#) [FCB4560RJ](#) [FCB2R47J](#) [SQPW2R047J](#) [WA8505-47RJI](#)