

# Aluminum Electrolytic Capacitors

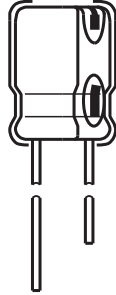

## FEATURES

- Polarized aluminum electrolytic capacitors, non-solid electrolyte
- Radial leads, cylindrical aluminum case
- Pressure relief for case  $\varnothing D \geq 6.3$  mm
- High CV per unit volume
- $\varnothing 5$  mm to  $\varnothing 25$  mm, 105 °C, 2000 h endurance
- Material categorization: for definitions of compliance please see [www.vishay.com/doc?99912](http://www.vishay.com/doc?99912)

**RoHS**  
COMPLIANT

## APPLICATIONS

- Decoupling, smoothing, filtering, buffering in SMPS
- General industrial, telecom, and domestic appliances
- Portable and mobile equipment (small size, low mass)

QUICK REFERENCE DATA		
DESCRIPTION	UNIT	VALUE
Nominal case sizes ( $\varnothing D \times L$ )	mm	5 x 11 to 25 x 45
Rated capacitance range	$\mu\text{F}$	1 to 33 000
Capacitance tolerance	%	$\pm 20$ (at 120 Hz, 20 °C)
Rated voltage range	V <sub>DC</sub>	6.3 to 450
Category temperature range	°C	-40 to +105
Endurance	h	2000
Shelf life	h	1000

ORDERING INFORMATION						
Part number example: <b>GRC00FE1021VTFL</b>						
<b>GRC</b>	<b>00</b>	<b>FE</b>	<b>102</b>	<b>1V</b>	<b>TF</b>	<b>L</b>
SERIES NAME	DESIGN / FORMING	DIMENSIONS	CAPACITANCE	VOLTAGE	PACKING	INTERNAL CODE
		See "Dimensions" table	See "Selection Chart"	See "Selection Chart"	00 = bulk TF = ammopack, formed lead <sup>(1)</sup> TN = ammopack, straight lead <sup>(1)</sup>	

**Note**
<sup>(1)</sup> See "Taping Specifications"

**ADDITIONAL ELECTRICAL DATA**

<b>LEAKAGE CURRENT</b> (Test conditions: $U_R$ , 20 °C)			
RATED VOLTAGE	TIME	CV	VALUE
6.3 V to 100 V	after 2 min		$I = 0.01 CV$ or 3 ( $\mu A$ ), whichever is greater
160 V to 450 V	after 5 min	$CV \leq 1000$	$I = 0.03 CV + 15$ ( $\mu A$ )
		$CV > 1000$	$I = 0.02 CV + 25$ ( $\mu A$ )

**Notes**

- Where, C = rated capacitance in  $\mu F$
- V = rated DC working voltage in V

<b>DISSIPATION FACTOR</b> ( $\tan \delta$ at 120 Hz, 20 °C)														
RATED VOLTAGE	6.3	10	16	25	35	50	63	100	160	200	250	350	400	450
$\tan \delta$ (max.)	0.23	0.20	0.16	0.14	0.12	0.10	0.09	0.08	0.12	0.14	0.17	0.20	0.25	0.25

**Note**

- When the capacitance exceeds 1000  $\mu F$ , 0.02 shall be added every 1000  $\mu F$  increase.

<b>LOW TEMPERATURE BEHAVIOR</b> (at 120 Hz)															
IMPEDANCE RATIO	CASE SIZE	RATED VOLTAGE													
		6.3	10	16	25	35	50	63	100	160	200	250	350	400	450
$\frac{Z_{(-25\text{ }^\circ\text{C})}}{Z_{(+20\text{ }^\circ\text{C})}}$	$\emptyset D < 16$	4	3	3	2	2	2	2	2	3	6	8	12	14	16
	$\emptyset D \geq 16$	6	4	4	3	3	3	3	3						
$\frac{Z_{(-40\text{ }^\circ\text{C})}}{Z_{(+20\text{ }^\circ\text{C})}}$	$\emptyset D < 16$	8	6	6	4	4	3	3	3	4	8	10	16	18	20
	$\emptyset D \geq 16$	12	10	8	8	8	8	6	6						

<b>MULTIPLIER OF RIPPLE CURRENT AS A FUNCTION OF FREQUENCY</b>			
FREQUENCY (Hz)	CAPACITANCE ( $\mu F$ )		
	< 100	100 < C ≤ 1000	1000 AND UP
60 (50)	0.70	0.75	0.80
120	1.00	1.00	1.00
500	1.30	1.20	1.10
1000	1.40	1.30	1.12
10 000 and up	1.50	1.35	1.15

<b>TEST PROCEDURES AND REQUIREMENTS</b>				
TEST	TEST TIME	CAPACITANCE CHANGE	DISSIPATION FACTOR	LEAKAGE CURRENT
Load life <sup>(1)</sup>	2000 h	Within $\pm 20$ % of initial value	Less than 200 % of specified value	Within specified value
Shelf life <sup>(2)</sup>	1000 h			

**Notes**

- (1) The specifications shall be satisfied when the capacitors are restored to 20 °C after the rated voltage applied with rated ripple current for 2000 h at 105 °C.
- (2) The above specifications shall be satisfied when the capacitors are restored to 20 °C after exposing them for 1000 h at 105 °C without voltage applied. The rated voltage shall be applied to the capacitors before the measurements for 160 V to 450 V (refer to JIS C 5101-4 4.1).

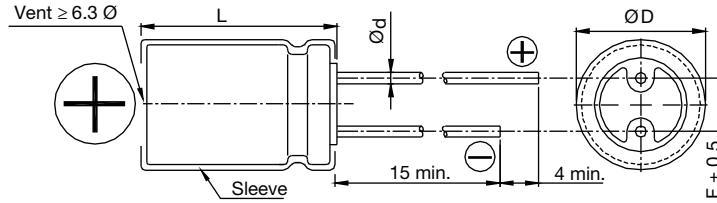
**DIMENSIONS** in millimeters

CASE SIZE CODE		$\text{Ø D} + 0.5$	L	$\text{Ø d}$	$F \pm 0.5$
AA	5 x 11	5	$11 \pm 1.0$	0.5	2
BA	6.3 x 11	6.3	$11 \pm 1.0$	0.5	2.5
PB	8 x 11.5	8	$11.5 \pm 1.0$	0.6	3.5
DC	10 x 12.5	10	$12.5 \pm 1.5$	0.6	5
DD	10 x 16	10	$16 \pm 1.5$	0.6	5
DE	10 x 20	10	$20 \pm 2.0$	0.6	5
DG	10 x 25	10	$25 \pm 2.0$	0.6	5
FD	12.5 x 16	12.5	$16 \pm 1.5$	0.6	5
FE	12.5 x 20	12.5	$20 \pm 2.0$	0.6	5
FG	12.5 x 25	12.5	$25 \pm 2.0$	0.6	5
JD	16 x 16	16	$16 \pm 1.5$	0.8	7.5
JE	16 x 20	16	$20 \pm 2.0$	0.8	7.5
JG	16 x 25	16	$25 \pm 2.0$	0.8	7.5
JS	16 x 31.5	16	$31.5 \pm 2.0$	0.8	7.5
JL	16 x 35.5	16	$35.5 \pm 2.0$	0.8	7.5
JK	16 x 40	16	$40 \pm 2.0$	0.8	7.5
KD	18 x 16	18	$16 \pm 1.5$	0.8	7.5
KE	18 x 20	18	$20 \pm 2.0$	0.8	7.5
KG	18 x 25	18	$25 \pm 2.0$	0.8	7.5
KS	18 x 31.5	18	$31.5 \pm 2.0$	0.8	7.5
KL	18 x 35.5	18	$35.5 \pm 2.0$	0.8	7.5
KK	18 x 40	18	$40 \pm 2.0$	0.8	7.5
KW	18 x 45	18	$45 \pm 2.0$	0.8	7.5
LK	22 x 40	22	$40 \pm 2.0$	1.0	10
PK	25 x 40	25	$40 \pm 2.0$	1.0	12.5
PW	25 x 45	25	$45 \pm 2.0$	1.0	12.5

**Note**

- Please see "Taping Specifications" for details on taped products



SELECTION CHART, DIMENSIONS, AND PERMISSIBLE RIPPLE CURRENT (at 120 Hz / 105 °C)															
V <sub>DC</sub>		6.3 V (0J)		10 V (1A)		16 V (1C)		25 V (1E)		35 V (1V)		50 V (1H)		63 V (1J)	
CAP.	CODE	Ø D x L	mA	Ø D x L	mA	Ø D x L	mA	Ø D x L	mA	Ø D x L	mA	Ø D x L	mA	Ø D x L	mA
2.2	2R2											5 x 11	20		
3.3	3R3											5 x 11	30		
4.7	4R7											5 x 11	33		
10	100											5 x 11	50		
22	220											5 x 11	78	6.3 x 11	86
33	330									5 x 11	75	5 x 11	90	6.3 x 11	100
47	470							5 x 11	97	5 x 11	90	6.3 x 11	120	6.3 x 11 8 x 11.5	130 141
100	101					5 x 11	110	6.3 x 11	142	6.3 x 11	150	8 x 11.5	188	10 x 12.5	235
220	221	5 x 11	140	6.3 x 11	175	6.3 x 11	190	8 x 11.5	236	8 x 11.5	270	10 x 12.5	300	10 x 16	335
330	331			6.3 x 11	200	8 x 11.5	270	8 x 11.5 10 x 12.5	310 335	10 x 12.5	350	10 x 16	410	10 x 20 12.5 x 16	510 460
470	471	6.3 x 11	230	8 x 11.5	290	8 x 11.5	310	10 x 12.5	380	10 x 16	460	10 x 20 12.5 x 16	530 425	12.5 x 20 16 x 16	640 665
1000	102	8 x 11.5	380	10 x 12.5	460	10 x 16	560	10 x 20 12.5 x 16	680 590	12.5 x 20 16 x 16	810 720	12.5 x 25 16 x 20	950 830	16 x 25	930
2200	222	10 x 16	690	10 x 20	760	12.5 x 16	780	12.5 x 25	1110	16 x 25 18 x 20	1260 1110	16 x 35.5 18 x 31.5	1470 1520	18 x 40	2280
3300	332	10 x 20 12.5 x 16	840 850	12.5 x 20 16 x 16	1100 940	12.5 x 25 16 x 16	1170 950	16 x 25 18 x 20	1440 1220	16 x 31.5 18 x 25	1420 1570	18 x 35.5	1770	22 x 40	2510
4700	472	12.5 x 20 16 x 16	1090 1010	12.5 x 25 16 x 16	1260 1060	16 x 20 18 x 16	1185 1290	16 x 31.5 18 x 25	1650 1550	18 x 35.5	1900	22 x 40	2340	25 x 40	3000
6800	682	12.5 x 25 16 x 20	1460 1190	16 x 20	1270	16 x 31.5 18 x 20	1930 1585	16 x 40 18 x 35.5	2000 2160	18 x 40	2250	25 x 40	2530		
10 000	103	16 x 20	1340	16 x 31.5 18 x 25	2220 1800	16 x 35.5 18 x 31.5	2210 2330	22 x 40 18 x 45	2720 2410						
15 000	153	16 x 31.5 18 x 25	2365 2290	18 x 31.5 16 x 35.5	2620 2590	18 x 40	2950	25 x 40	3200						
22 000	223	16 x 40 18 x 35.5	2800 2930	18 x 40	3230	22 x 40	3460								
33 000	333	18 x 45	3080	22 x 40	4090	25 x 45	4500								



<b>SELECTION CHART, DIMENSIONS, AND PERMISSIBLE RIPPLE CURRENT (at 120 Hz / 105 °C)</b>															
<b>V<sub>DC</sub></b>		<b>100 V (2A)</b>		<b>160 V (2C)</b>		<b>200 V (2D)</b>		<b>250 V (2E)</b>		<b>350 V (2V)</b>		<b>400 V (2G)</b>		<b>450 V (2W)</b>	
<b>CAP.</b>	<b>CODE</b>	<b>Ø D x L</b>	<b>mA</b>	<b>Ø D x L</b>	<b>mA</b>	<b>Ø D x L</b>	<b>mA</b>	<b>Ø D x L</b>	<b>mA</b>	<b>Ø D x L</b>	<b>mA</b>	<b>Ø D x L</b>	<b>mA</b>	<b>Ø D x L</b>	<b>mA</b>
1.0	010											6.3 x 11	21	8 x 11.5	27
2.2	2R2	5 x 11	30			6.3 x 11	30	6.3 x 11	35	6.3 x 11	35	8 x 11.5	39	8 x 11.5	39
3.3	3R3	5 x 11	31			6.3 x 11	39	6.3 x 11	40	8 x 11.5	43	8 x 11.5	45	8 x 11.5	45
4.7	4R7	5 x 11	36			6.3 x 11	43	8 x 11.5	45	8 x 11.5 10 x 12.5	45 55	8 x 11.5 10 x 12.5	50 55	8 x 11.5 10 x 12.5	50 55
10	100	6.3 x 11	54	8 x 11.5	65	8 x 11.5	65	10 x 12.5	92	10 x 16	95	10 x 16	95	10 x 20	105
22	220	6.3 x 11 8 x 11.5	93 99	10 x 12.5	110	10 x 16	140	10 x 16	140	12.5 x 20	220	12.5 x 20	160	12.5 x 20	160
33	330	8 x 11.5	130	10 x 16	150	10 x 20	170	12.5 x 16	175	12.5 x 25 16 x 16	215 205	16 x 20	225	16 x 20 18 x 16	225 220
47	470	10 x 12.5	165	10 x 20	195	12.5 x 16	215	12.5 x 20 16 x 16	230 245	16 x 20	255	16 x 25	295	16 x 25 18 x 20	280 285
68	680			12.5 x 20	275	12.5 x 20 16 x 16	265 290	16 x 20	320	18 x 25 16 x 31.5	360 370	18 x 25 16 x 31.5	360 375	16 x 35.5 18 x 31.5	400 420
100	101	10 x 20 12.5 x 16	265 290	12.5 x 25	355	16 x 20 18 x 16	365 360	16 x 25 18 x 20	425 415	18 x 31.5 16 x 35.5	460 430	18 x 35.5	540	18 x 40	560
150	151			16 x 25	470	18 x 20	510	16 x 31.5 18 x 25	550 535	18 x 40	600	22 x 40	730	22 x 40	770
220	221	12.5 x 25 16 x 16	440 420	16 x 31.5	660	18 x 31.5	750	18 x 35.5	760	25 x 40 22 x 45	865 850	22 x 45	930		
330	331	16 x 25	620	18 x 35.5	820	18 x 40	965	22 x 40	1140	25 x 45	1070				
470	330	16 x 31.5 18 x 25	715 745	22 x 40	1130	22 x 40	1130	25 x 40	1325						
1000	102	18 x 40	1275												
2200	222	25 x 45	2400												

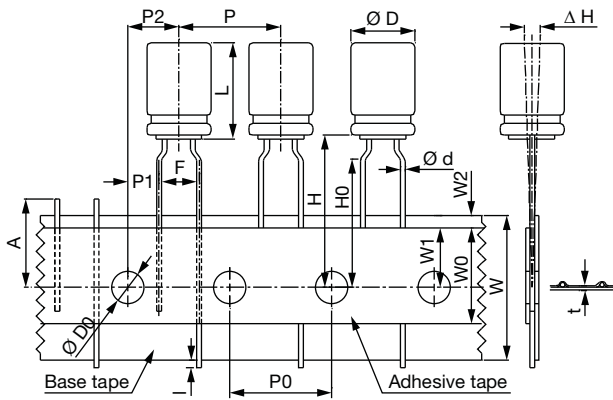

Fig. 1

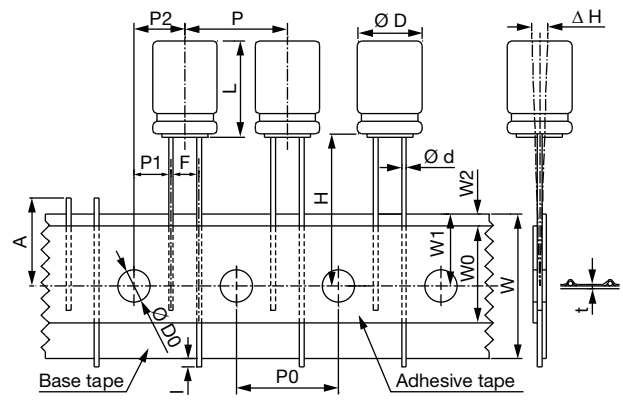

Fig. 3

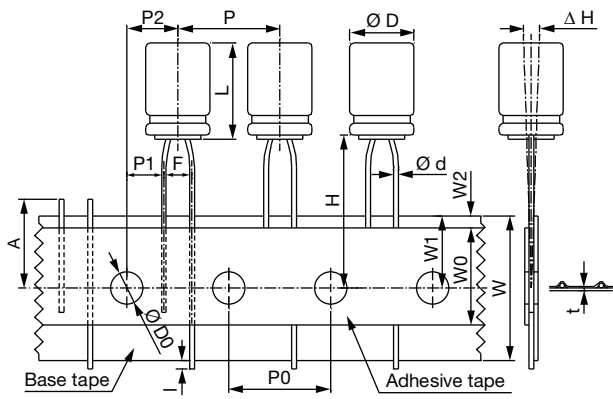

Fig. 2

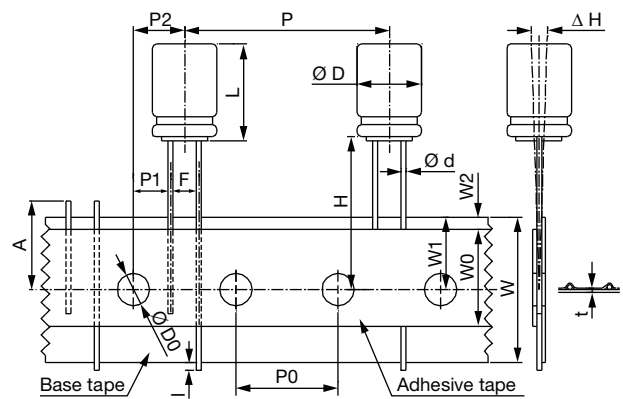

Fig. 4

TAPE SPECIFICATIONS in millimeters																												
PACKING	TF						TN																					
	5			7 to 9			≥ 11			5		≥ 7		7 to 9		11.5 to 20		9 to 25										
Ø D	3	4*	5	6.3	8	5	6.3	8*	5	6.3	8	3	4*	5	6.3	8	5	6.3	8	8	TOL.	10	12.5	TOL.				
SYMBOL	0.4		0.45		0.5		0.5		0.6		0.4		0.45		0.5		0.5		0.6		± 0.05		0.6		± 0.05			
F	5.0		5.0		5.0		5.0		5.0		2.5		2.5		3.5		3.5		3.5		+ 0.8 / - 0.2		5.0		+ 0.8 / - 0.2			
H	17.5		17.5		17.5		18.5		20.0		17.5		17.5		17.5		18.5		18.5		± 0.75		18.5		± 0.75			
H0	16.0		16.0		16.0		-		-		-		-		-		-		-		± 0.5		-		± 0.5			
P	12.7		12.7		12.7		12.7		12.7		12.7		12.7		12.7		12.7		12.7		± 1.0		12.7		25.4		± 1.0	
P0	12.7		12.7		12.7		12.7		12.7		12.7		12.7		12.7		12.7		12.7		± 0.2		12.7		± 0.2			
P1	3.85		3.85		3.85		3.85		3.85		5.1		5.1		4.6		4.6		4.6		± 0.5		3.85		± 0.7			
P2	6.35		6.35		6.35		6.35		6.35		6.35		6.35		6.35		6.35		6.35		± 1.0		6.35		± 1.3			
W	18.0		18.0		18.0		18.0		18.0		18.0		18.0		18.0		18.0		18.0		± 0.5		18.0		± 0.5			
W0	6.0		10.0		10.0		10.0		12		6.0		10.0		10.0		10.0		12.0		Min.		12.0		Min.			
W1	9.0		9.0		9.0		9.0		9.0		9.0		9.0		9.0		9.0		9.0		± 0.5		9.0		± 0.5			
W2	1.5		1.5		1.5		1.5		1.5		1.5		1.5		1.5		1.5		1.5		Max.		1.5		Max.			
A	11.0		11.0		11.0		11.0		11.0		11.0		11.0		11.0		11.0		11.0		Max.		11.0		Max.			
Ø D0	4.0		4.0		4.0		4.0		4.0		4.0		4.0		4.0		4.0		4.0		± 0.2		4.0		± 0.2			
ΔH	0		0		0		0		0		0		0		0		0		0		± 1.0		0		± 1.0			
l	1.0		1.0		1.0		1.0		1.0		1.0		1.0		1.0		1.0		1.0		Max.		1.0		Max.			
t	0.7		0.7		0.7		0.7		0.7		0.7		0.7		0.7		0.7		0.7		± 0.2		0.7		± 0.2			
Fig. No.	1						2		3		2		3		3		3		3		3		3		4			

Notes

- For Ø D = 10, H = 20.0 ± 0.5 is available, in this case, the dimensions of H is not specified
- 4 Ø in mark of "\*" is 4 Ø x 7 L the same spec. "TN" packing: 5 to 6.3 Ø x 11 L in H is 18.5
- For 3 to 8 Ø x 5 L, W0 = 10.0 is available

**PACKAGING**

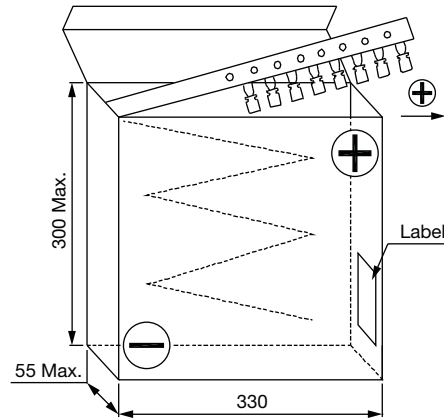

Fig. 5 - Ammopack box

PACKAGING QUANTITY (pcs per box)							
Ø D (mm)	3	4	5	6.3	8	10	12.5
TF, TN	3000	2000	2000	2000	1000	500	300

**Note**

- The component shall be oriented on the tape as such that the positive lead is leading or the negative lead is leading with customer's request

## X-ON Electronics

Largest Supplier of Electrical and Electronic Components

*Click to view similar products for [Aluminium Electrolytic Capacitors - Radial Leaded](#) category:*

*Click to view products by [Vishay](#) manufacturer:*

Other Similar products are found below :

[LXY50VB4.7M-5X11](#) [RFO-100V471MJ7P#](#) [ECE-A1EGE220](#) [NCD681K10KVY5PF](#) [NEV1000M25EF-BULK](#) [NEV100M35DC](#)  
[NEV100M63DE](#) [NEV220M25DD-BULK](#) [NEV.33M100AA](#) [NEV4700M50HB](#) [NEV.47M100AA](#) [NEVH1.0M250AB](#) [NEVH3.3M250BB](#)  
[NEVH3.3M450CC](#) [KME50VB100M-8X11.5](#) [ES5107M016AE1DA](#) [ESX472M16B](#) [476CKH100MSA](#) [477RZS050M](#) [UVX1V101KPA1FA](#)  
[UVX1V222MHA1CA](#) [KME25VB100M-6.3X11](#) [VTL100S10](#) [VTL470S10](#) [511D336M250EK5D](#) [052687X](#) [ECE-A1CF471](#)  
[EKXG451ELL820MM30S](#) [686CKR050M](#) [NRE-S560M16V6.3X7TBSTF](#) [ERZA630VHN182UP54N](#) [UPL1A331MPH](#) [NEV1000M6.3DE](#)  
[NEV100M16CB](#) [NEV100M50DD-BULK](#) [NEV2200M16FF](#) [NEV220M50EE](#) [NEV2.2M50AA](#) [NEV330M63EF](#) [NEV4700M35HI](#)  
[NEV4.7M100BA](#) [NEV47M16BA](#) [NEV47M50CB-BULK](#) [NEVH1.0M350AB](#) [NEVH2.2M160AB](#) [NEVH3.3M350BC](#) [TER330M50GM](#)  
[477KXM035MGBWSA](#) [B43827A1106M8](#) [EKMA160EC3101MF07D](#)